

Public Disclosure Authorized

Public Disclosure Authorized

Public Disclosure Authorized

Public Disclosure Authorized



Thirsty Energy

Modeling the Water-Energy Nexus in China

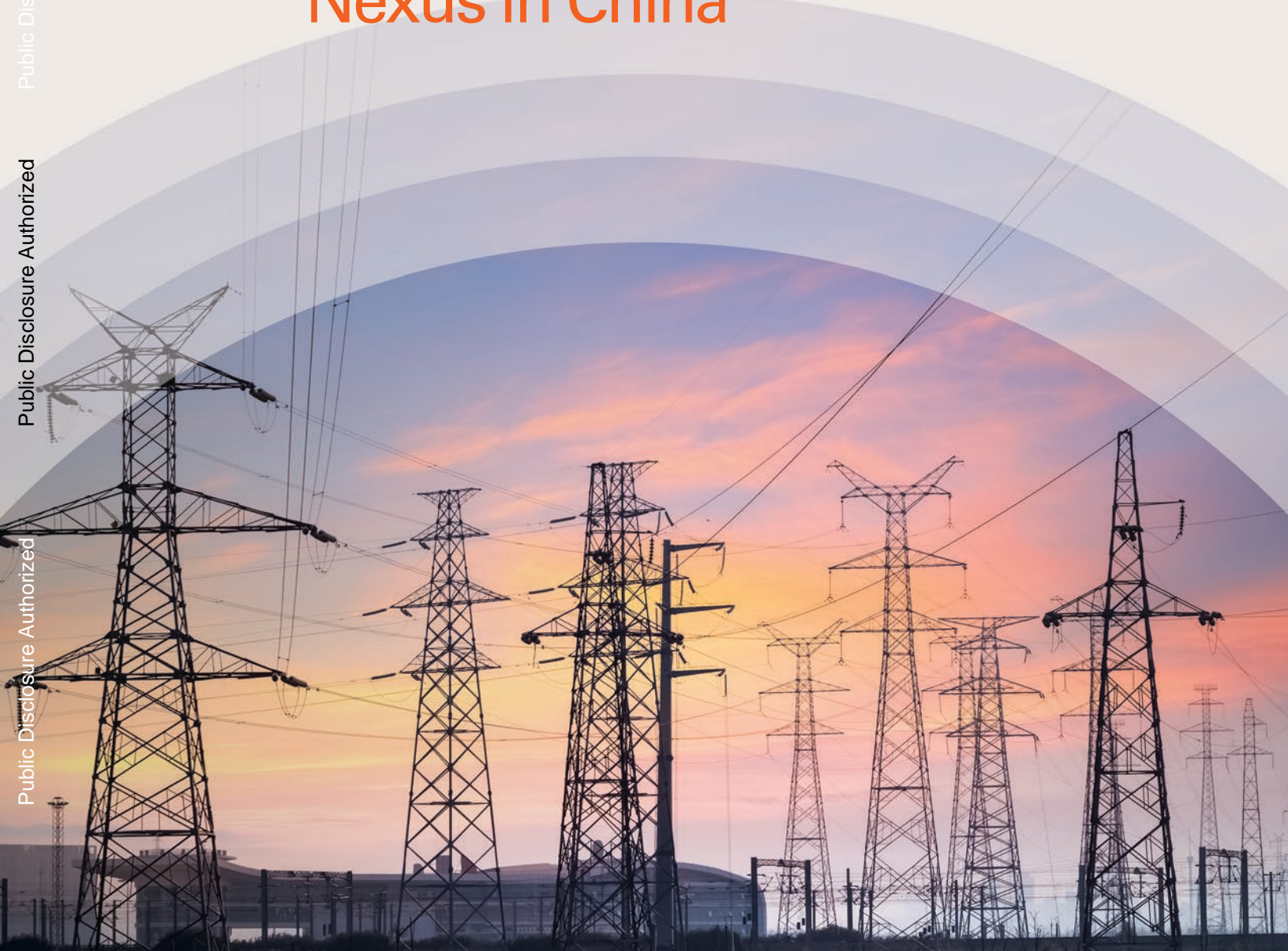



Thirsty Energy

Modeling the Water-Energy
Nexus in China

© 2018 International Bank for Reconstruction and Development /The World Bank

1818 H Street NW, Washington, DC 20433

Telephone: 202-473-1000; Internet: www.worldbank.org

This work is a product of the staff of The World Bank with external contributions. The findings, interpretations, and conclusions expressed in this work do not necessarily reflect the views of The World Bank, its Board of Executive Directors, or the governments they represent.

The World Bank does not guarantee the accuracy of the data included in this work. The boundaries, colors, denominations, and other information shown on any map in this work do not imply any judgment on the part of The World Bank concerning the legal status of any territory or the endorsement or acceptance of such boundaries.

Rights and Permissions

The material in this work is subject to copyright. Because The World Bank encourages dissemination of its knowledge, this work may be reproduced, in whole or in part, for noncommercial purposes as long as full attribution to this work is given.

Please cite the work as follows: World Bank. 2018. "Thirsty Energy: Modeling the Water-Energy Nexus in China." World Bank, Washington, DC.

Any queries on rights and licenses, including subsidiary rights, should be addressed to World Bank Publications, The World Bank Group, 1818 H Street NW, Washington, DC 20433, USA; fax: 202-522-2625; e-mail: pubrights@worldbank.org.

Cover photo: © chuyu/Bigstock.

Cover design: Bill Praguski, Critical Stages, LLC.

Contents

Acknowledgments		ix
Abbreviations		xi
Chapter 1	Summary	1
	Context	2
	Approach	4
	Methodological Observations	5
Chapter 2	Why Consider the Water-Energy Nexus in China?	9
Chapter 3	Water in China	13
	Water Resources in China	14
	Water Supply in China	15
	Water Demand in China	17
	Water for the Energy Bases	18
	Water Withdrawal for the Energy Industry	20
	Water Withdrawal for Power Generation	20
Chapter 4	Energy in China	23
	Regional Resources	24
	Regional Resource Supply	26
	Power Plants	27
	Coal Chemical	30
Chapter 5	Water Modeling	31
	Methodology	32
	Regional Water Resources	34
	Water in the Eastern Inner Mongolia Energy Base	34
	WSSC for the Energy Bases	39
	Water Supply Cost Curves under Climate Change	46
Chapter 6	Energy Modeling	57
	Regional Consideration	58
	Water Representation in the TIMES-ChinaW Model	60

Chapter 7	Exploration of China’s Future Water-Energy Nexus	63
	Base and Reference Scenarios	64
	Examining the Effects of Alternative Policies and Climate Change	66
	Effect of Water Cost and Once-Through Cooling Policy	70
	Effect of Water Cost and Carbon Dioxide Policy	76
	Coal Reduction Policies	88
	Effect of Climate Change on Water Supply and Thereby the Energy System	97
	Reference versus All Policies: Effect of Water Supply Cost	99
	Core Policies: Effect of Water Supply Cost and Carbon Dioxide Policy	100
	Coal Peak versus Carbon Dioxide Policy	108
	Non-Fossil Plan versus Non-Fossil Policy	111
	All Policies: Effect of Climate Change	123
Chapter 8	Methodology Observations and Limitations of the Initial Analysis	127
Chapter 9	Conclusion	131
	Case Study Findings	132
	Next Steps	136
Appendix A	Water Model	139
	Model Description	140
	Assumptions	140
	Analytical Method for Water Supply in Energy Bases	143
	Analytical Method of Temporal-Spatial Changing of Water Resources Quantity in Energy Bases	146
	Regional Water Resources Quantity under Climate Change Scenario	148
Appendix B	Energy Model	151
	Model Description	152
	Assumptions	154
Appendix C	Energy in China	159
	Coal, Oil, and Gas Supply: Base Year	160
	Installed Power Plants Capacity and Cooling Requirements	161
	Coal, Oil, and Gas Potential	162
	Hydro Potential	162
	Wind Potential	164

Solar Potential	164
Costs	165
Coal Chemical Industry	165
Water Factors for Power Generation	166
Water Factors for Other Energy-Related Activities	168

References 169

Box

1.1 Energy Bases in China	3
---------------------------	---

Figures

1.1 Summary Metrics: Cumulative Change from the Base Scenario, 2010–50	8
3.1 Composition of Total Water Supply, 2014	17
3.2 Composition of Total Water Demand, 2014	17
3.3 Comparison of Water Demand between Southern and Northern China, 2014	18
3.4 Water Withdrawals for Coal-Fired Power Plants in the Major Energy Bases (Recirculating and Air Cooling)	21
4.1 Major Energy Resource Potential, by Region (Coal, Oil, Gas, and Wind)	25
4.2 Total Domestic Resource Extraction, 2010	27
4.3 Coal Power Plant Capacity, 2010	28
4.4 Hydro, Wind and Nuclear Power Plant Capacity, 2010	29
4.5 Capacity of Solar Photovoltaic and Wind, 2015	29
5.1 Simplified Research Routing for Water Modeling	33
5.2 Composition of Total Water Supply in the Eastern Inner Mongolia Energy Base, 2012	35
5.3 Composition of Total Water Use in the Eastern Inner Mongolia Energy Base, 2012	35
5.4 Composition of Total Water Supply in the Ordos Energy Base, 2012	36
5.5 Composition of Total Water Use in the Ordos Energy Base, 2012	37
5.6 Composition of Total Water Supply in the Shanxi Energy Base, 2012	38
5.7 Composition of Total Water Use in the Shanxi Energy Base, 2012	38
5.8 Composition of Total Water Supply in the Xinjiang Energy Base, 2012	39
5.9 Composition of Total Water Use in the Xinjiang Energy Base, 2012	39
5.10 Unit Water Supply Cost Curve of the Eastern Inner Mongolia Energy Base	41
5.11 Unit Water Supply Cost Curve of the Ordos Base	42
5.12 Unit Water Supply Cost Curve of the Shanxi Base	44
5.13 Unit Water Supply Cost Curve of the Xinjiang Base	45
5.14 Eastern Inner Mongolia Energy Base Water Supply Options (Energy Sector Only)	48
5.15 Ordos Energy Base Water Supply Options (Energy Sector Only)	50
5.16 Shanxi Energy Base Water Supply Options (Energy Sector Only)	52

5.17	Xinjiang Energy Base Water Supply Options (Energy Sector Only)	54
6.1	Simplified TIMES-ChinaW Reference Energy System (RES)	59
6.2	Transportation of Coal, Natural Gas, and Electricity, 2010	59
6.3	Water Representation for Each Region in the TIMES-ChinaW Model	61
7.1	Power Sector Water Withdrawal: Effect of Water Supply Cost	71
7.2	Coal Power Plant Capacity, by Cooling Type: Effect of Water Supply Cost Cluster	72
7.3	Electricity Generation, by Type: Effect of Water Supply Cost Cluster	73
7.4	Water Withdrawal by the Energy Sector, by Type and by Region: Effect of Water Supply Cost Cluster	74
7.5	Total Cumulative System Cost (2010-2050): Water Cost and CO ₂ Policy	76
7.6	Energy Sector Water Withdrawals and Consumption, by Type: Water Cost and CO ₂ Policy	77
7.7	Power Sector Water Withdrawals, by Plant Type: Water Cost and CO ₂ Policy	78
7.8	Share of Non-Fossil Energy in the Newly Built Power Plant Capacity	79
7.9	Coal Power Plant Capacity, by Cooling Type: Water Cost and CO ₂ Policy	79
7.10	Power Plant capacity and Change: Water Cost and CO ₂ Policy	80
7.11	Electricity Generation Structure of Base and Reference: Water Cost and CO ₂ Policy, 2050	81
7.12	Electric Power Plant New Builds and Change, by Type: Water Cost and CO ₂ Policy	82
7.13	Generating Capacity and Difference, by Region: Water Cost and CO ₂ Policy	83
7.14	Regional Electricity Trade: Water Cost and CO ₂ Policy	84
7.15	Final Energy and Change, by Fuel: Water Cost and CO ₂ Policy	84
7.16	Final Energy and Change, by Sector: Water Cost and CO ₂ Policy	85
7.17	CO ₂ Emissions and Change: Water Cost and CO ₂ Policy	86
7.18	CO ₂ Emissions: Water Cost and CO ₂ Policy, 2050	87
7.19	Power Sector Emissions, by Pollutant Type: Water Cost and CO ₂ Policy	88
7.20	Total Cumulative System Cost (2010-2050) and Difference of the Core Government Policies	89
7.21	Total Cumulative System Cost (2010-2050) and Difference of Core Policies without CO ₂	90
7.22	Energy Sector Water Withdrawal and Difference, by Type: Core Policies with CO ₂	90
7.23	Electric Generation and Difference, by Plant Type: Core Policies with CO ₂	91
7.24	Change in Electricity Generation, by Region: Core Policies with CO ₂	93
7.25	New Power Plant Builds, by Type: Core Policies with CO ₂	94
7.26	CO ₂ Emission and Difference in the Core Scenarios: Core Policies with CO ₂	95
7.27	Power Sector Emissions, by Pollutant Type: Core Policies with CO ₂	96
7.28	Total Cumulative System Cost (2010-50) and Difference for the RCP Scenarios	98
7.29	Energy Sector Water Withdrawal and Difference, by Region: Climate Change Cluster	98
7.30	Total Cumulative System Cost (2010-50) and Difference: Effect of Water Cost Cluster	100
7.31	Total Cumulative System Cost (2010–50) and Difference of Core Policy Cases without the Cost of Water	101
7.32	Energy Sector Water Withdrawal, by Type: Core Policy Cases without the Cost of Water	101
7.33	Power Sector Water Withdrawal, by Plant Type: Core Policy Cases with the Cost of Water	103
7.34	Electric Generation and Difference, by Type: Core Policy Cases without Water Costs	104
7.35	Electricity Generation, by Type: Core Policy Cases without the Cost of Water, 2050	105
7.36	Final Energy and Change, by Fuel: Core Policy Cases without the Cost of Water	106
7.37	Final Energy, by Sector: Core Policy Cases without the Cost of Water	107

7.38	CO ₂ Emissions, by Sector: Core Policy Cases without the Cost of Water	108
7.39	Total Cumulative System Cost (2010–50) and Difference: Coal Peak versus CO ₂ Policy Cluster	109
7.40	Change in New Power Plant Builds: Coal Peak versus CO ₂ Policy Cluster	109
7.41	Change in CO ₂ Reductions: Coal Peak versus CO ₂ Policy Cluster (difference from Base)	110
7.42	Total Cumulative System Cost (2010–50) and Difference: Non-Fossil Plan versus Non-Fossil Policy	111
7.43	Change in Electricity Capacity: Non-Fossil Plan versus Non-Fossil Policy Cluster	112
7.44	Energy Sector Water Withdrawal and Consumption, by Type: Non-Fossil Plan versus Non-Fossil Policy Cluster	112
7.45	Water Consumption, by Type: Non-Fossil Plan versus Non-Fossil Policy Cluster	114
7.46	Electricity Generation, by Fuel: Non-Fossil Plan versus Non-Fossil Policy Cluster	114
7.47	Total Cumulative System Cost (2010–50) and Difference: All versus Reference Impact of Climate Change Cluster	115
7.48	Energy Sector Water Withdrawal and Difference, by Type: All versus Reference Climate Change Cluster	115
7.49	Electricity Generation and Difference, by Type: All versus Reference Climate Change Cluster	116
7.50	CO ₂ Emissions and Change: All versus Reference Climate Change Cluster	118
7.51	Primary Energy Supply and Change: All versus Reference Climate Change Cluster	119
7.52	Change in Imports and Domestic Production: All versus Reference Climate Change Cluster	120
7.53	Change in Final Energy Consumption, by Sector: All versus Reference Climate Change Cluster	121
7.54	Change in Power Plant Builds: All versus Reference Climate Change Cluster	122
7.55	Shift in Regional Electricity Generation: All versus Reference Climate Change Cluster	122
7.56	Total Cumulative System Cost (2010–50) and Difference: All Policies Climate Change Cluster	123
7.57	Energy Sector Water Withdrawal and Change, by Type: All Policies Climate Change Cluster	124
7.58	Electricity Generation, by Fuel Type: All-Policies Climate Change Cluster	125
7.59	Electricity Generation, by Region: All Policies Climate Change Cluster	125
7.60	CO ₂ Emissions: All Policies Climate Change Cluster, 2010–50	126
A.1	The Framework of Climate Land Surface and Hydrology Model System	141
A.2	Method for the Water Supply Cost Curve Calculation	145
A.3	RCP Water Supply Curves for Major Basins, 2010–50	149
B.1	Simplified RES of TIMES-ChinaW	153
B.2	Simplified Representation of Demand Sectors in TIMES-ChinaW	154
B.3	Projection Method for Energy Service Demand in Iron and Steel Sector	155
B.4	Production Process for Iron and Steel Sector in TIMES-ChinaW	156
B.5	Energy Service Demand (indexed from 1 in 2010)	156
C.1	Difference of Final Energy Consumption between Old and New Balance Sheet, 2010	160

Maps

B.1.1	Energy Bases in China	3
3.1	Water Resources Regions in China	16

3.2	Major Energy Bases in China	19
4.1	Solar Resource Potential, by Region	26

Tables

3.1	Major Energy Bases and Locations	15
4.1	Regional Power Plant Capacity, 2010	28
4.2	Coal Chemical Industry Capacity, 2010 and 2015	30
5.1	Water Supply Options for the Eastern Inner Mongolia Energy Base, BAU, and RCPs	41
5.2	Water Supply Options for the Ordos Energy Base, BAU, and RCPs	42
5.3	Water Supply Options for the Shanxi Energy Base, BAU, and RCPs	44
5.4	Water Supply Options for the Xinjiang Energy Base, BAU, and RCPs	46
7.1	Base and Reference Scenario Cumulative Metrics, 2010–50	66
7.2	Scenario Matrix	67
7.3	Policy Issues Examined	69
7.4	Scenario Clusters for Assessment	69
7.5	Costs and Savings of Core Policies	102
7.6	Relative Change in Carbon Dioxide Emissions: Coal Peak versus Carbon Dioxide Policy Cluster	110
9.1	Water Savings, Carbon Dioxide Reductions, and System Cost Impacts	135
A.1	CLHMS Required Variables and Corresponding Variables in CNRM-CM5	142
B.1	Major Sources for TIMES-ChinaW Energy Data	157
C.1	Coal, Oil, and Gas Extraction, 2010	160
C.2	Power Capacity of Air Cooling, 2010	161
C.3	Power Capacity with Water Cooling (Recirculating), 2010	162
C.4	Power Capacity of Water Cooling (Once-Through), 2010	162
C.5	Proved Remaining Reserves	163
C.6	Alternative Gas Potential	163
C.7	Hydro Potentials	163
C.8	Wind Power Potential, by Region	164
C.9	Coal and Gas Transportation Cost (with Distance under Consideration)	165
C.10	Coal to Liquid Project, 2015	166
C.11	Coal to Gas Project, 2015	166
C.12	Water Withdrawal Factors for Selected Electricity Generation Technologies	167
C.13	Water Withdrawal Factors in Energy Extraction and Other Conversion Process	168

Acknowledgments

This report is a product of the Thirsty Energy Initiative, led by the Energy and Extractives and Water Global Practices. It was prepared by a team led by Diego J. Rodriguez and Morgan Bazilian and comprising Anna Delgado and Fernando Miralles-Wilhelm (University of Maryland). The Thirsty Energy Initiative aims to ensure sustainable development of water and energy resources. Information on the initiative and material on water and energy can be found on the Thirsty Energy website, www.worldbank.org/thirstyenergy.

The preliminary draft report was developed by a joint team from the Institute of Energy, Environment and Economy, Tsinghua University, Beijing, China (Wenying Chen and Nan Li), the State Key Laboratory of Simulation and Regulation of Water Cycle in River Basin, Institute of Water Resources and Hydropower Research, Beijing, China (Yongnan Zhu and Yizi Shang), and DecisionWare Group (Pat DeLaquil and Gary Goldstein).

The team would like to thank the following for their contributions: Xin-Zhong Liang (University of Maryland), Todd Johnson, and Winston Yu for their constructive feedback in peer reviewing the document; Bert Hofman, Jie Tang, Maria Angelica Sotomayor, Sudipto Sarkar, Charles Feinstein, Bekele Debele, Liping Jiang, and Ximing Peng for their guidance and support; and Erin Barrett for her support with editing and publishing.

This work was made possible by financial contributions from the Water Partnership Program (WPP) and the Energy Sector Management Assistance Program (ESMAP <http://www.esmap.org>).

Abbreviations

BCM/a	billion cubic meter per annum
CCS	carbon capture and storage
CERFACS	Centre Européen de Recherche et de Formation Avancée/European Centre for Research and Advanced Training
CHP	combined heat and power
CLHMS	Climate Land Surface and Hydrology Model System
CMIP5	Coupled Model Intercomparison Project phase 5
CNRM-GAME	Centre National de Recherches Météorologiques—Groupe d' études de l'Atmosphère Météorologique/ France National Centre for Meteorological Research – Meteorological and Atmospheric Studies Group
CSP	concentrating solar power
ERI	Energy Research Institute
ETSA	Energy Technology Systems Analysis
GELATO	Global Experimental Leads and Ice for Atmosphere and Ocean
HadCM3	Hadley (Centre) Coupled (general climate circulation) Model
IEA	International Energy Agency
IPCC-AR5	Intergovernmental Panel on Climate Change, Fifth Assessment Report
IPSL-CM5A-LR	Institut Pierre Simon Laplace Climate Model (Low Resolution)
IWHR	China Institute for Water Resources
LSX	Land-Surface eXchange (hydrology model)
NEMO	Nucleus for European Modelling of the Ocean
NGCC	natural gas combined cycle
PJ	petajoules (10 ¹⁵ joules)
PV	photovoltaic
RCP	representative concentration pathway
RES	reference energy system
SURFEX/TRIP	Surface Externalisée/Total Runoff Integrating Pathways
TIMES	The Integrated MARKAL-EFOM System
UWSC	unit water supply cost

01

Summary



© Wu Zhiyi / World Bank

Context

The World Bank's global initiative Thirsty Energy assists countries with tackling water and energy planning challenges in an integrated manner. A primary aim of Thirsty Energy is to demonstrate the importance of combined planning approaches to tackle the water-energy nexus by developing methods and evidence-based operational tools to analyze potential tradeoffs. This report documents the second of two case studies undertaken by the initiative. The first study was recently completed for South Africa (World Bank 2016).

China is increasingly aware of the complex interdependencies between water and energy. China's rapid economic development has been accompanied by a similar rapid increase in energy supply and demand, which is dominated by coal, resulting in significant air pollution and carbon dioxide (CO₂) emissions. In addition, the coal energy supply chain is water-intensive—from mining and washing the coal to cooling power plants. The water-energy nexus challenge is further complicated by the fact that the majority of the planned new energy projects are located in the four northern energy bases of China (see box 1.1). Although these energy bases have significant energy resources, they are among the most water-stressed areas of the country.

To mitigate its water issues, the government of China enacted several policies with targets on water use, water efficiency for industry (including energy) and agriculture, and water quality improvements on a national and regional scale for 2015, 2020, and 2030. These policies are known as the 3 Red Lines water policies. Although all of these policies affect the energy sector, the government further added a "water allocation plan

Box 1.1

Energy Bases in China

The four northern energy bases are located in Eastern Inner Mongolia, Shanxi, Ordos (including Shaanxi, Ningxia, and Gansu), and Xinjiang provinces and account for significant shares of domestic coal (more than half), oil, and natural gas reserves. The southern energy base (Yungui) and other regions that are not associated with the northern energy bases are shown as the Other region in map B1.1. Throughout this report, the term Energy Bases (when capitalized) is used to refer to the four northern energy bases: Eastern Inner Mongolia, Shanxi, Ordos, and Xinjiang.

Map B1.1 Energy Bases in China

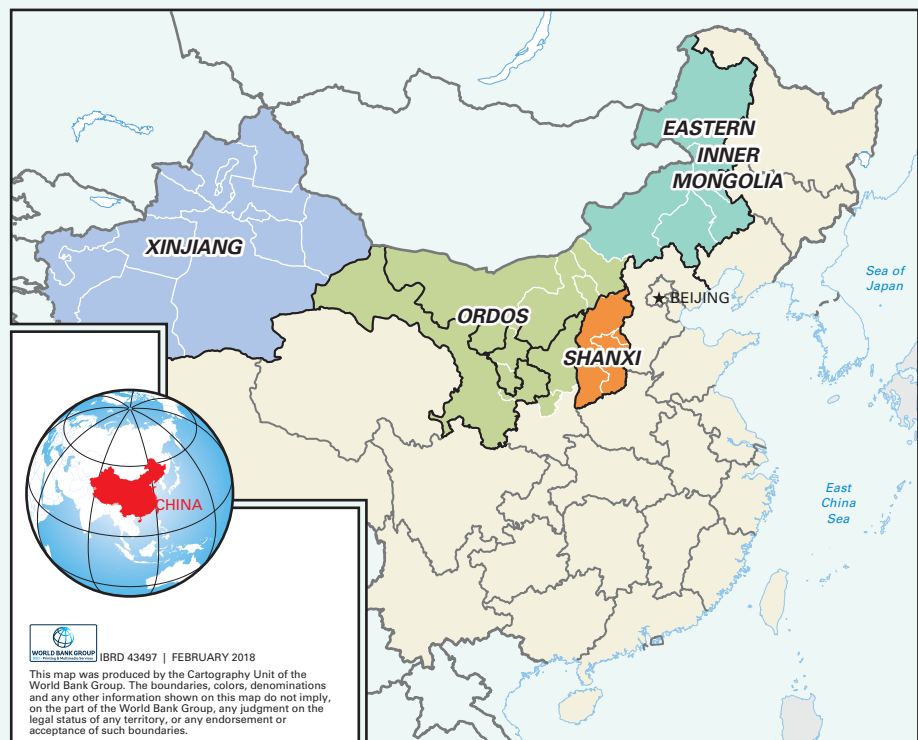

Source: IWHR with data from National Energy Administration 2012.

for the development of coal bases” to reduce water usage, improve water efficiency, and reduce wastewater discharges in the coal sector. This part of the policy also requires future large-scale coal projects in water-scarce regions to be developed in partnership with local water authorities and requires mostly all new coal-fired power plants built in the northern China region to use dry cooling systems and encourages other regions to

do so. At the same time existing smaller and less efficient coal-fired plants are to be upgraded or phased out in favor of larger and more efficient facilities.

To better assess the water-energy nexus challenge in China, the Thirsty Energy initiative engaged the China Institute for Water Resources (IWHR) and Hydropower Research under the auspices of the Ministry of Water Resources and the Institute of Energy, Environment, and Economy of Tsinghua University (TU) to establish a new multiregional, water-smart energy system planning model: TIMES-ChinaW (described in chapter 6). Chapter 2 of this report provides an overview of the water-energy nexus in China, and the current water and energy picture in China are described in chapters 3 and 4. Chapter 5 describes the methodology and approach for preparing the water supply cost curves and integrating that information into the TIMES-ChinaW model. Chapter 7 explores China's future water-energy nexus using the abovementioned model and summarizes the main findings for specific water, energy, economic, and environmental impacts that resulted from the examined energy and environmental policies. Chapter 8 explains the limitation of the methodology and the analysis and Chapter 9 draws conclusions on main findings in China and mentions next steps for consideration to continue advancing this increasingly critical aspect of sustainable planning.

Approach

The approach to create a water-smart energy sector planning tool can be described through the following steps:

1. Identify a detailed energy systems planning model that can be modified to include various water constraints, supply regions, and needs. The energy systems optimization model, called TIMES-China, from Tsinghua University, was the starting point.
2. Use the latest hydrological models developed by Institute for Water Resources and Hydropower Research to determine likely water supplies to each region. Then collect local data on the water supply infrastructure needed to meet growing demand from all sectors (agriculture, municipalities, other industry, and energy) to determine the water available for the energy sector. The Institute for Water Resources and Hydropower Research prepared this information from their existing models and in discussion with their regional agencies.
3. Incorporate this water supply information for each region into the energy systems model (TIMES-ChinaW) in the form of an aggregated water supply cost curves (WSCC). This was a coordinated activity between the Institute for Water Resources and Hydropower Research and Tsinghua University, in consultation with the World Bank.
4. The TIMES-ChinaW model closely follows current changing trends in the energy sector, as reflected in the 13th Five-Year Plan (2016–20), including a slowdown in

demand because of slower economic growth (as reflected by more modest gross domestic product [GDP] projection) and the rapid shift away from coal-fired generation to Non-fossil alternatives.

5. Analyze a variety of policy scenarios in accordance with different aspects of the 13th Five-Year Plan to investigate the effect of including the cost and availability of water when analyzing these policies and to identify these policies' effects on the energy sector's water requirements, as well as how climate change may influence future energy-water tradeoffs.

Methodological Observations

The study results in terms of the process and modeling include these key observations:

- A national-level energy systems optimization model was regionalized regarding energy resource supply and power plant locations. The regional costs and limitations for water supply were incorporated to create a water-smart energy sector planning tool.
- A combination of primary data collection on water availability and demand, and basin-level water system planning models was used to provide data on the costs and availability of specific future bulk water supply and infrastructure options. However, when aggregated to the energy base level, local aspects of the delivery of water may not be captured, for example, when a power plant is not located near the water source and thus requires additional pumping to deliver the water needed.
- In the first case study under Thirsty Energy conducted in South Africa, the investment cost and timing of the specific water supply options were input into the TIMES energy system model directly. For the case study in China, the water supply cost curves are introduced into the energy model and payback requirements are not captured (because of data unavailability).
- Only energy sector's water demands (rather than the total water demand including non-energy use) were considered in the water supply cost curves levels, which give an incomplete picture of China's total water demand. However, there are provisions (water supply cost curve steps) that allow the purchase of water rights from the agriculture sector by the energy sector if warranted and cost-effective.

Key Findings

The main finding of this study is that current government policies in the energy sector result in reduced water use and that most of the policies being pursued to mitigate

climate change impacts reduce both CO₂ emissions and water needs by the energy sector—with only modest increase in energy system cost.

The study highlights the following findings regarding the water-energy nexus in China.¹

- Properly including the cost of water supply, along with current policies aimed at requiring dry cooling for new coal plants in the Energy Bases, plans to close older smaller less efficient coal plants, the push to promote renewables and the commitment to achieve the goals stated in China’s Nationally Determined Contribution (NDC), all embodied in the Reference scenario, combine to directly help the energy sector comply with important aspects of the water 3 Red Lines policies including the following:
 - Water withdrawal by the energy sector is lowered by 30 percent, from 29.83 billion cubic meters (m³) in 2015 to 20.96 billion m³ in 2030, contributing to meeting the target of the Red Line for total withdrawal control before 2030, with withdrawals dropping further to 17.18 billion m³ in 2050 (42 percent) as a result of the adoption of non-fossil such as solar photovoltaics (PV), wind and nuclear in the power sector and due to the coal chemical industry being cut back in upstream processes.
 - For similar reasons, wastewater releases drop from 21.59 billion m³ in 2015 to 11.26 billion m³ in 2030 (48 percent), dropping further to 9.34 billion m³ in 2050 (57 percent) helping to address the water quality red line.
 - Water consumption by the energy sector first increases slightly from 8.24 billion m³ in 2015 to 9.7 billion m³ (18 percent) in 2030 because of the substitution of once-through cooling coal power plants by new ones using recirculating cooling—which withdrawal much less water but have slightly higher consumption factors. However, water consumption by the energy sector later decreases to 7.84 billion m³ (5 percent) in 2050 because of the substitution of coal power plant by Non-fossil generation that uses less or no water and the decrease of coal-to-gas and coal-to-liquids in the upstream sector.
 - The intensity of water withdrawal for energy per unit of GDP moves from 8.42 m³ per thousand US dollars to 2.31 m³ per thousand US dollars, which is a relative index in line with the second red line of controlling the water withdrawal per unit of industrial added value.
- Including regional water supply costs has a significant effect on the electricity generation cooling technology choice, confirming the economic rationale of the existing policies in the power sector that require dry and/or recirculating cooling by thermoelectric power plants in the northwest region.

¹ This study is conducted primarily to demonstrate the insights that can be derived from a more integrated water-energy planning tool. It is not intended as a detailed policy study for China.

- The potential effects of climate change on water supply were estimated according to a medium- to long-term climatic model. It shows the Energy Bases (main energy-producing regions in the north of China) will become somewhat less water constrained, whereas the Other (wet) region is likely to experience less rainfall—although not enough to dramatically affect the energy sector. Therefore, climate change effects on water availability to the energy system in China appear not to be so significant. However, effects that result from localized droughts and floods could have a negative impact on energy facilities that the model cannot predict. Moreover, this analysis has not assessed the effects on hydropower, which is mostly located in the Other region, which could be impacted by climate change.
- The analysis investigated 29 scenarios starting with a Base scenario, reflecting the anticipated evolution of China’s energy system in the absence of new policies. A Reference scenario shows that China’s nationally determined contribution (NDC) CO₂ mitigation target² is achievable with an acceptable 2.6 percent increase in the total cost of the energy system, when imposed on top of the aforementioned 13th Five-Year Plan policies. Additional scenarios were investigated to examine the long-term effects of the 13th Five-Year Plan policies, and policies for consideration beyond the 2020 horizon of the 13th Five-Year Plan along with possible climate change implications for the energy system.
- The Reference scenario with CO₂ mitigation policies in place shows the following:
 - More than 100 billion m³ less water is needed for the energy sector over the planning horizon compared with the Base scenario with no CO₂ constraint because of the power generation shift from traditional coal power plants to Non-fossil sources that require less amount of fresh water (for example, nuclear along the coast using seawater for cooling, and large amounts of solar and wind added in the Energy Bases).
 - Starting from now, once-through power plant cooling types will be gradually replaced by air-cooling in the north as required by the government, and they will be completed phased out by 2035. Furthermore, when including the cost of water, once-through plants follow a similar fate in the Other region being replaced by air cooling or recirculating cooling.
 - By 2050, about 15 petajoules (PJ) per annum of coal and oil are displaced from the final energy mix and replaced by 8 PJ per annum increased use of natural gas and electricity from nuclear and renewables, with associated demand-side energy efficiency improvements.
 - CO₂ emissions are reduced by 125 billion metric tons over the planning horizon.
- A Coal Peak policy scenario was developed to be stricter than the Reference scenario (CO₂ constraint). It increases the total system cost by 0.6 percent because it forces

² Limiting 2020/2030 energy sector emissions to 9.5/11.0 Billion Mt 6.1/15.4% below the Baseline.

earlier investments into constructing nuclear and renewable power plants, and retiring coal power plants that are kept operating longer in the Reference scenario. This scenario results in a 49 percent drop in water withdrawal from 2015 levels in 2030 compared with only a 30 percent reduction in the Reference scenario. However, both scenarios have nearly the same water needs in 2050 (around 42 percent less than 2015 levels).

- The All-policies scenario encompassing each of the policies examined from the 13th Five-Year Plan reduces water withdrawals for energy use because of the earlier investments into building nuclear and renewable power plants driven by the Coal Peak policy. System cost increases by 1.3 percent, and CO₂ emissions are reduced by an additional 12.6 billion tons cumulatively through 2050 compared with the Reference scenario because of the actions generated by the Coal Peak policy for faster retirement of existing coal plants. Due to the Coal Peak policy there is also a 49 percent drop in water withdrawal from 2015 levels in 2030, with slightly less water needed in 2050 (around 44 percent less than 2015 levels). The increased investment in nuclear and renewable plants increases the price of electricity, which then drives some of the energy sector’s final demands away from electricity to natural gas, partly offsetting the sector’s emission reductions.

Figure 1.1 provides metrics for the three key scenarios: Reference, Coal Peak, and All-policies, which all include a limit on CO₂ emissions. The metrics are the changes in the cumulative amount of water consumption (or use, the net amount of water consumed by the power plants, as opposed to the total amount of water withdrawn from the various water supply sources), CO₂ emission reductions, and energy system cost, from the Base scenario. The figure illustrates that reductions in CO₂ emissions and water consumption for energy are strongly aligned and significant. Note that achieving the NDC reduction of CO₂ emissions has an associated marginal cost of \$75/t CO₂ in 2020 and \$578/t CO₂ in 2050, so deeper cuts may prove to be quite challenging and costly.

Figure 1.1

Summary Metrics: Cumulative Change from the Base Scenario, 2010–50

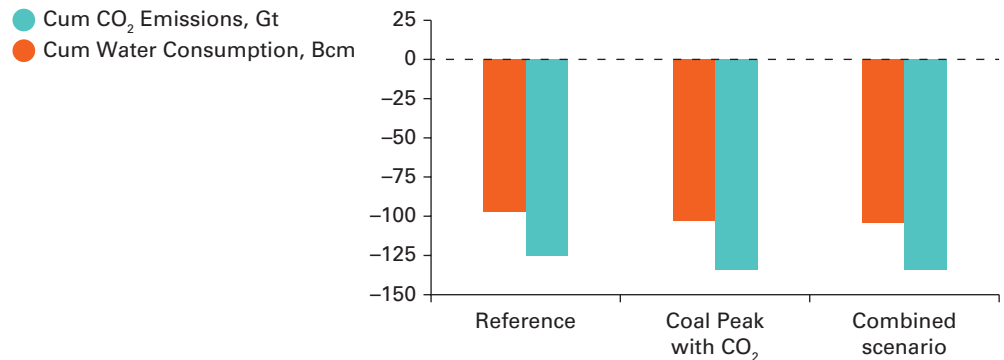

Note: \$/t = dollars per ton; bcm = billion cubic meters; Gt = gigaton.

02

**Why
Consider
the Water-
Energy
Nexus in
China?**



© lensnmatter

Water and energy are crucial for life and are entwined; the use of one resource depends on the availability of the other. The sustainable supply of services from these two resources therefore effectively operates as a set of integrated challenges commonly referred to as the *water-energy nexus*. Recognizing these challenges, the World Bank's global initiative, Thirsty Energy, assists countries with tackling water and energy management challenges in an integrated manner, rather than through the traditional decoupled silo approach to assessing future infrastructure needs. In addition, the uncertainty that accompanies climate change further exacerbates this difficult situation, especially given the long-term nature of the planning process and lifetimes of water and energy infrastructure investments. A primary aim of Thirsty Energy is to demonstrate the importance of combined energy and water management approaches and develop methods and evidence-based operational tools to implement in practice to prepare for any potential tradeoffs.

Over the past three decades, China's economy has experienced rapid development, with annual growth rates of approximately 10 percent. Gross domestic product (GDP) per capita reached US\$8,069 in 2015, with an annual growth rate of around 7 percent. Primary energy consumption increased to 4.3 billion tons of coal equivalent in 2015, recording an average annual growth rate of 5.8 percent in the past 30 years

(China Statistical Yearbook 2016, China Energy Statistical Yearbook 2016). At around 70 percent of the total, coal has dominated the energy supply, resulting in significant air pollution and CO₂ emissions that reached 9.1 billion tons in 2015. To meet its growing energy demand, (see the “Assumptions” section in appendix B), China has a very ambitious strategy to increase fossil fuel and non-fossil fuel power capacity and upstream production (including coal, gas, and oil) along with aggressively promoting renewables sources such as wind and solar. Most of these energy generation processes require large amounts of water. For example, the coal life cycle is very water-intensive—from coal mining and washing to cooling of power plants. Several factors further complicate the water-energy challenge. First, water resources are unevenly distributed in the country, with many developed regions such as those in northern China already undergoing water scarcity. Second, the majority of energy resources are in already water-stressed areas that face competition for the resource from other sectors and municipalities.

China is increasingly aware of the complex interdependencies between energy and the environment, energy security, and sustainable economic growth; and there is growing awareness of the water-energy nexus. The Thirsty Energy initiative engaged the Institute for Water and Hydropower Resources, which reports to the Ministry of Water Resources and to the Institute of Energy, Environment, and Economy of Tsinghua University, to establish a new advanced multiregional water-smart energy system planning model called TIMES-ChinaW. This energy-water planning study assesses the effect of critical energy policy options as identified by China’s National Energy Agency in the 13th Five-Year Plan and the implications of including the cost of water in the assessment of these options. This report provides an overview of the water-energy nexus in China, describes the methodology and approach to integrating the cost and supply of water into the TIMES-ChinaW model, and summarizes the main findings of specific energy, economic, and environmental effects resulting from the examined policies.

03

**Water in
China**



© Brian Ong

Water Resources in China

China's total annual average water resources is 2.77 trillion m³ and its per-capita water resources quantity is 2,000 m³ per year, which is about one-quarter of the world's average.¹ The influence of the East Asian monsoon and China's complicated regional topography, lead to significant variations in the spatial distribution and seasonal characteristics of precipitation, resulting in very uneven distribution of water resources in the country. In general, there is more water in the south than in the north, more along the coast than inland, and more in mountainous areas than in the plains.

In 2014, China's total water resources were 2.73 trillion m³, and annual precipitation was 622.3 millimeters (mm), almost equivalent to its historical average level. The annual water resources per capita were 2,006 m³. At a regional level, China's northern region (including the Songhua River, Liaohe River, Haihe River, Yellow River, and the

¹ Unless otherwise specified, the water resources and water withdrawal data used in this study are all from the China Water Resources Bulletin (Ministry of Water Resources 2012) and the National Comprehensive Water Resources Planning 2010). Note that water withdrawal is defined as the amount of water taken from a water source (for example, lake, river, ocean, aquifer). Consumption refers to water that is lost from the total water withdrawn. Discharge is the amount of water that is returned to the water source (sometimes in a different state). Therefore, the water consumed is equal to the water withdrawn minus the water discharged to the environment.

Table 3.1**Major Energy Bases and Locations**

Modeling region [Energy Base]	Coal Mine Bases	Provinces
Eastern Inner Mongolia	Eastern Inner Mongolia	Eastern part of Inner Mongolia
Ordos	Shandong, Eastern Ningxia, Northern Shaanxi, and Huanglong	Western part of Inner Mongolia, Ningxia, Shaanxi, and Gansu
Shanxi	Northern Shanxi, Middle Shanxi, and Eastern Shanxi	Shanxi
Xinjiang	Xinjiang	Xinjiang
Other [Yungui and plants not in integrated energy bases]	Lianghuai, Western Shandong Middle Hebei, and Henan	Anhui, Shandong, Hebei, and Henan
	Yungui	Yunnan, Guizhou, Sichuan, and Chongqing

Huaihe River areas) averages 316.9 mm of precipitation, and water resources totaled 465.85 billion m³, accounting for 17.1 percent of the national total. The annual water resources per capita of the northern region were 750 m³, which is far less than half of the national average. For China's southern region (including the Yangtze River area, rivers in the southeast, the Pearl River area, and rivers in the southwest), its average precipitation was 1,205.3 mm and water resources totaled 2.26 trillion m³, accounting for 82.9 percent of China's total. The annual water resources per capita of this region were 3,061 m³. Consequently, the Thirsty Energy initiative aims to explore more closely the water-energy nexus in the water-constrained northern Energy Bases, where the majority of energy production occurs (see map B.1.1 and table 3.1).

Water Supply in China

According to China's national conditions and considering water's fluid nature and multifunctional characteristics, China has adopted a unified management system that different governmental departments implement. The Ministry of Water Resources ensures sustainable development and use of water resources and implementation of a unified supervision and management scheme. According to the natural drainage system and ecological environment, China is divided into 10 major rivers basins (see map 3.1). To strengthen and unify the management of water resources in important river basins, the Ministry of Water Resources established seven local committees according to the jurisdictional scope of the river and lake basins: the Yangtze River Water Resources Commission, the Yellow River Water Conservancy Commission, the Haihe River Water Conservancy Commission, the Huaihe Water Conservancy Commission, the Pearl River Water Resources Commission, the Songliao Water Resources Commission, and the Taihu Basin Authority. Directly affiliated with the Ministry of Water Resources, these committees manage and supervise water resources in their river basins.

Map 3.1

Water Resources Regions in China

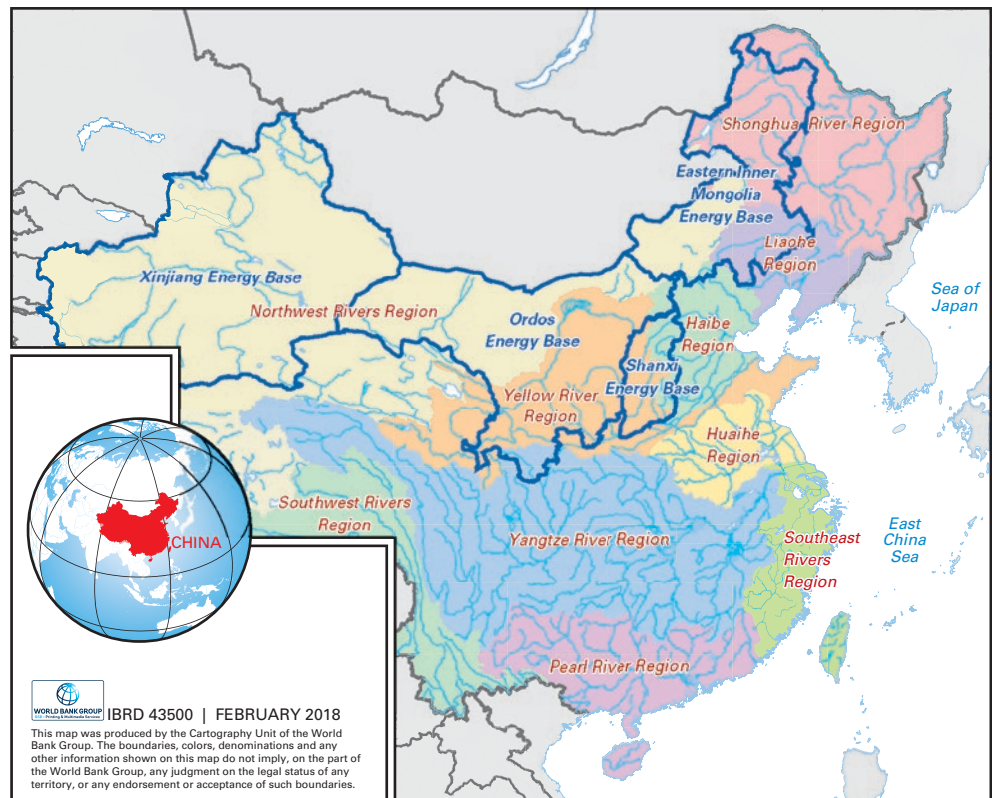

Source: IWHR with watershed data from the Ministry of Water Resources.

The local water authority, governed by the local government above the county level (municipal or provincial), is in charge of unified management and supervision of water resources in their respective administrative regions in accordance with their jurisdictional limits. Other relevant governmental departments above the county level are responsible for the development and use of water resources in their respective administrative regions according to the division of their duties, such as water resources development, use, conservation, and protection. The provincial water resources department or municipal water bureau is responsible for supervising local water resources management according to the division of duties between their respective levels of governments.

China's total water supply (water used for agricultural, industrial, household, environmental, or other activities) was 609.5 billion m³ in 2014, including 492.1 billion m³ of surface water, which accounted for 80.8 percent of the total, and 92.1 billion m³ of groundwater water, which made up 18.3 percent of the total. Other water sources,

Figure 3.1

Composition of Total Water Supply, 2014

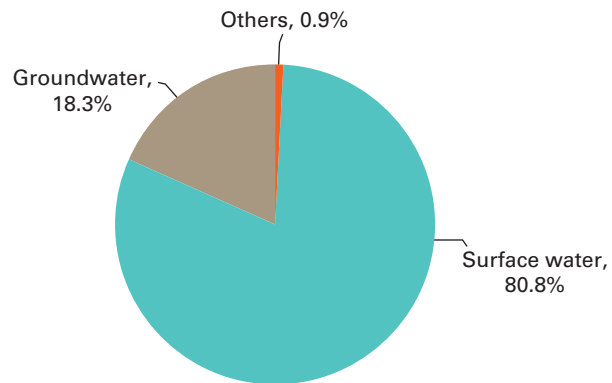

including recycled sewage, harvested rainwater, and desalinated water, excluding seawater in direct use (for example, for cooling nuclear power plants), was 5.7 billion m³ and accounted for 0.9 percent of the total water supply (see figure 3.1).

Water Demand in China

In 2014, China's total water demand was 609.5 billion m³, matching the supply mentioned in the previous section. Of that 609.5 billion m³, 76.7 billion m³ was for domestic use accounting for 12.6 percent, 135.6 billion m³ was for industrial use (including energy) accounting for 22.2 percent, 386.9 billion m³ was for agricultural use accounting for 63.5 percent, and 10.3 billion m³ of water was for ecological replenishment accounting for 1.7 percent of the total (see figure 3.2).

Figure 3.2

Composition of Total Water Demand, 2014

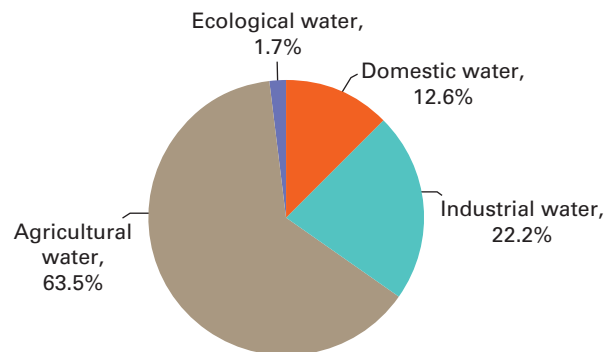

According to regional water resources statistics, water demand in the southern area was 331.47 billion m³, which amounted to 54.4 percent of the total demand in China. In terms of water usage in the south, 50.77 billion m³ of water was used for domestic purposes, 102.92 billion m³ for industrial purposes, 174.11 billion m³ for agricultural use, and 3.61 billion m³ for ecological use.

Water demand in the northern area is 278.02 billion m³, which amounted to 45.6 percent of the total water demand of China (see figure 3.3). The North's relative share of total water demand amounted to 33.8 percent for domestic purposes, 24.1 percent for industrial purposes, 55.0 percent for agricultural use, and 65.0 percent for ecological use.

Figure 3.3 Comparison of Water Demand between Southern and Northern China, 2014

Billion cubic meters

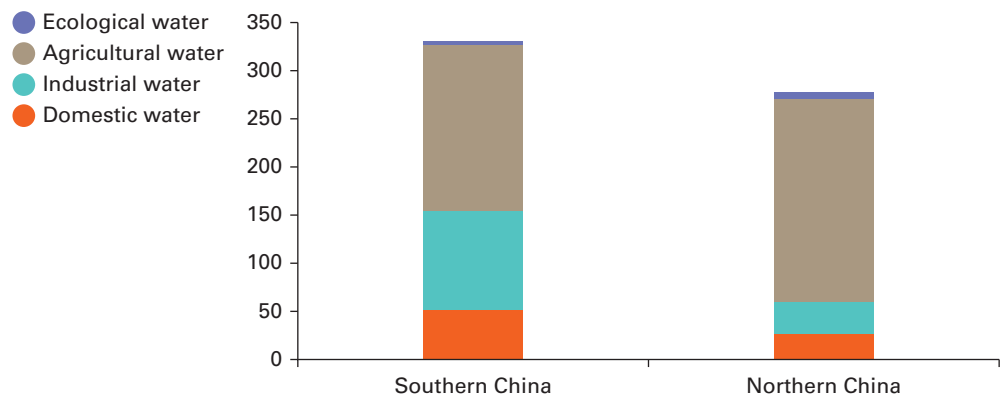

Water for the Energy Bases

China is rich in coal, poor in oil, and deficient in gas. In 2015 coal accounted for about 63.7 percent of the total primary energy consumption in China (National Bureau of Statistics 2016). To sufficiently satisfy the energy demands for economic development, China's National Energy Agency proposed five national integrated energy bases during the period of the 12th Five-Year Plan (2010–15), including the Eastern Inner Mongolia, Ordos, Shanxi, Xinjiang, and Yungui energy bases. These bases have been reemphasized in the 13th Five-Year National Electric Power Development Plan (2016–20), which also deals with other energy policy issues such as Coal Peak, coal chemicals, and shale gas discussed in this case study (National Development and Reform Commission

and National Energy Administration 2016). Table 3.1 lists these bases and identifies their provincial locations and major coal bases.

Map 3.2 shows that, except for the Yungui Energy Base, all other energy bases are located in arid or semiarid regions that are deficient in water. These regions are endowed with about 71 percent of China’s national coal reserves and only 13 percent of total water resources. Therefore, severe water resource limitations are foreseen as a challenge to China’s energy development strategies if coal keeps having a dominant role.

Chapter 5 presents an overview of the methodology for modeling future water supplies, and chapter 6 describes the representation of the water-energy nexus in the TIMES-ChinaW energy systems model. Appendix A provides a detailed description of the water modeling framework.

Map 3.2 Major Energy Bases in China

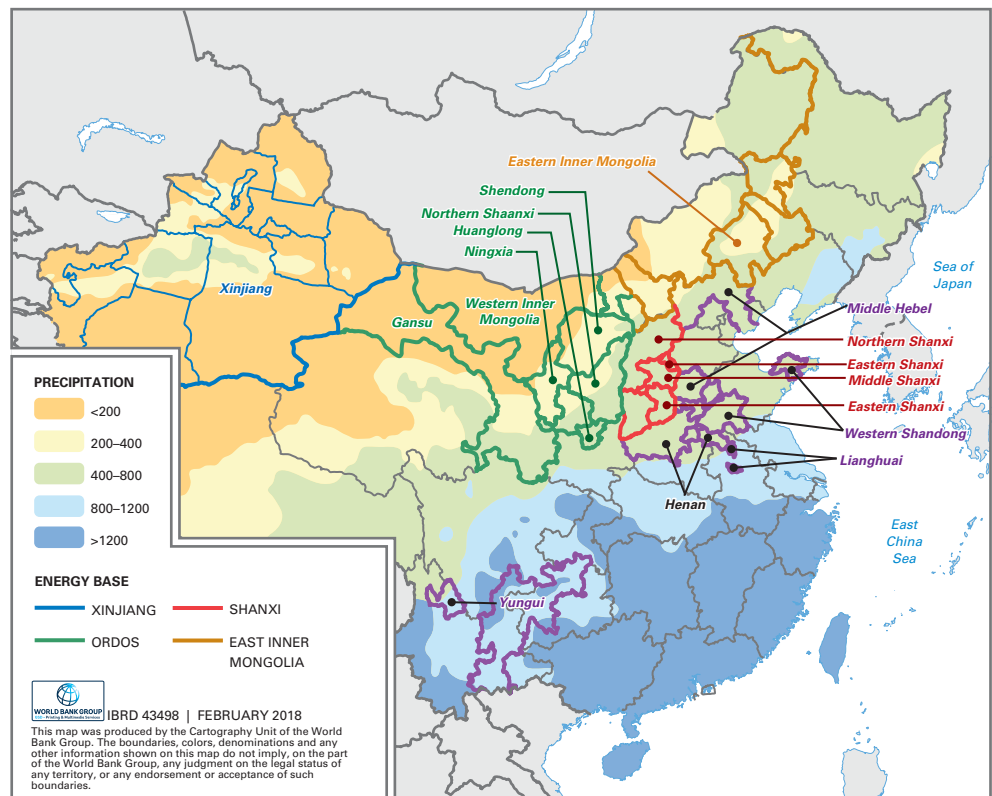

Source: IWHR with data from the National Energy Administration 2012; State Council of China 2014 and Xie et al. 2007.

Water Withdrawal for the Energy Industry

China's energy reserve structure and water endowment pattern do not match very well. China's coal reserves identified by the end of 2010 amounted to 1.34 trillion tons, about 300 billion tons more than that in 2005. Ninety percent of the incremental amount was in the arid western region, and the national strategy for coal development indicates a gradual movement westward.

The total water withdrawal for the thermal power sector is 46 billion m³, including 37.3 billion m³ for once-through power plants (fossil fuelled and nuclear power plants). Nuclear power plants are all located in the Other region and use seawater for cooling.² Because these nuclear plants are all located in the Other region, their water needs are not explicitly tracked in TIMES-ChinaW.

Current water withdrawal in China's major Energy Bases amounts to 0.343 billion m³ in the Eastern Inner Mongolia Energy Base, which is 52.7 percent of the all industrial water withdrawal (that is, power and other industrial uses) is used for energy; 1.30 billion m³ in the Ordos Energy Base, which is 81.0 percent of the industrial water withdrawal; 0.78 billion m³ in the Shanxi Energy Base, which is 53.4 percent of the industrial water withdrawal, and 0.27 billion m³ in the Xinjiang Energy Base, which is 24.5 percent of the industrial water withdrawal. Water withdrawal in these Energy Bases comprises a high ratio of total industrial water withdrawal in those regions.

Continued development of coal production, coal-fired power plants, and coal chemical industries is expected to reach 4.1 billion tons by 2020 (according to the 13th Five-Year Plan), with an anticipated associated increase water demand for the energy sector.

Water Withdrawal for Power Generation

The coal sector is one of the major water users in China. In 2015, water consumption for the thermal power industry for electricity generation was 5.92 billion m³ (excluding once-through cooling) with an average water consumption factor of 1.4 m³/MWh (cubic meter per megawatt-hour). The average wastewater discharge was 0.07 m³/MWh (China Electricity Council 2016).

Despite a sharp rise in the efficiency of water use for thermal power generation in China during recent years, water withdrawals continue to grow steadily because of

²TIMES-ChinaW includes coefficients for water withdrawal (amount taken from the various water sources) and water consumption (withdrawal minus discharged water), but the data used for calibration are only for water withdrawal, so these values are subsequently presented.

Figure 3.4

Water Withdrawals for Coal-Fired Power Plants in the Major Energy Bases (Recirculating and Air Cooling)

Billion cubic meters

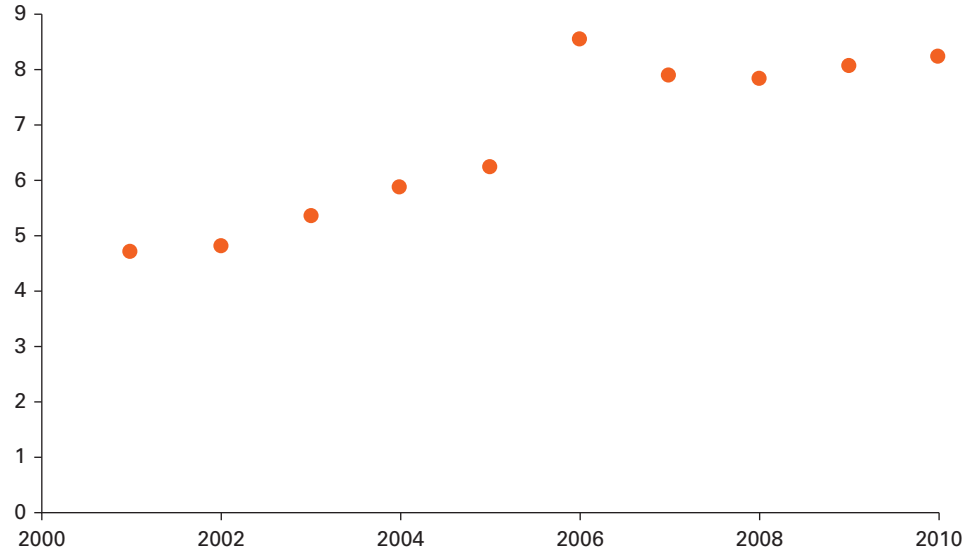

Source: China Electricity Council 2011b.

rapid increases in the demand for electricity. Recent trends in China’s water withdrawals for coal-fired power plants can be seen in figure 3.4.

Given the uneven distribution of water resources in China, with more in the south and east and less in the north and west, the government promotes appropriate thermal power plant cooling methods according to the natural availability of water resources. In northern China, where water is scarce, air-cooling units have been mostly adopted in recent years and are now required by the government. For the relatively water abundant South, wet cooling units are adopted, namely once-through cooling or recirculating cooling systems; they tend to be more efficient and less expensive. However, with the improvement of environmental protection measures, the cooling water discharge temperature is restricted in southern China, so most of the thermal power generation adopts recirculating cooling systems.

04

**Energy in
China**



© Chiu Ho-yang

Table 3.1 lists the five regions used to characterize the TIMES-ChinaW model, which are also depicted in map B.1.1. These regions include the four main northern Energy Bases in the country: Eastern Inner Mongolia, Shanxi, Ordos (including Shaanxi, Ningxia, and Gansu), and Xinjiang. Together, the Energy Bases account for significant shares of domestic coal (more than half), oil, and natural gas resources, but they comprise only 5.8 percent of the water resources in China (China Water Resources Bulletin 2015). The fifth (Other) region includes the southern energy base (Yungui) and other regions and resources that are not associated with the main Energy Bases.

Regional Resources

The uneven distribution of energy resources is a significant challenge for future development. According to the China Statistical Yearbook (2016), national proven reserves of coal are 5,104 exajoules (EJ) (10^{18} joules [J]), with the four northern Energy Bases making up 73 percent of the total. National technically recoverable reserves of oil are 146 EJ, and the portion in the four northern Energy Bases is 38 percent. National

Figure 4.1

**Major Energy Resource Potential, by Region
(Coal, Oil, Gas, and Wind)**

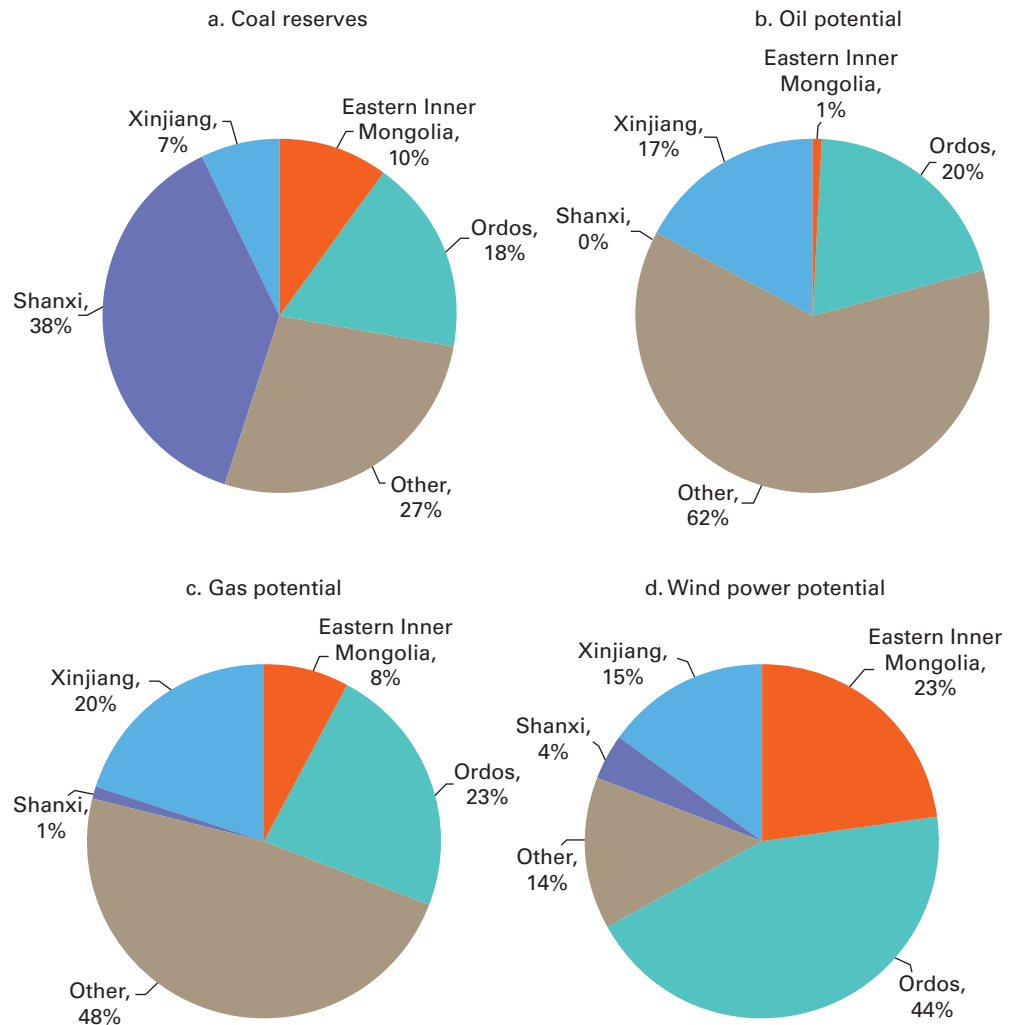

technically recoverable reserves of gas are 202 EJ, with the four northern Energy Bases comprising 52 percent of the total. These Energy Bases also comprise 56 percent of the 2,600 gigawatts (GW) of wind technical capacity. Figure 4.1 shows the share of these fuel reserves and wind potential for each energy base. According to the China's Wind and Solar Energy Resources Bulletin of China's Meteorology Administration, the solar resources are distributed more in the west than in the east and more in the north than in the south, as map 4.1 shows. Therefore, the Energy

Map 4.1

Solar Resource Potential, by Region

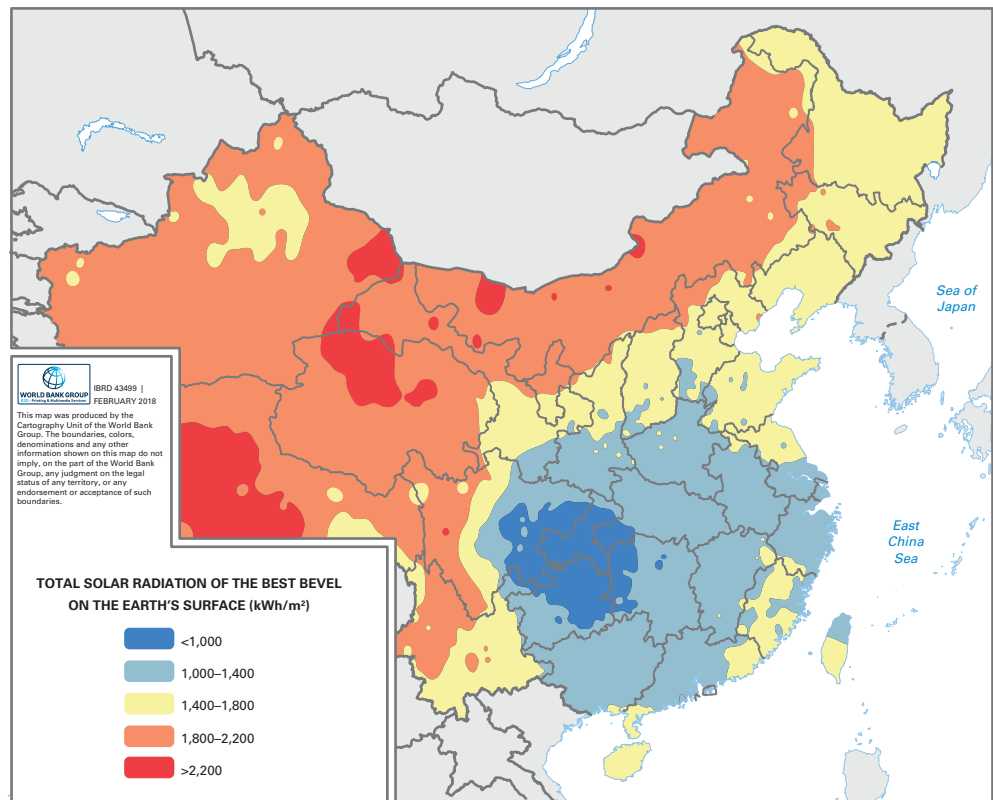

Source: CMA 2014.

Bases face the same transmission infrastructure and losses issues inherent in transmitting electricity to the demand centers whether the generation comes from coal-fired plants or from renewable energy plants.

Regional Resource Supply

Figure 4.2 shows the regional breakdown of fossil fuel extraction in 2010, by energy base. Coal was produced in all bases, and the Energy Bases accounted for 59.5 percent of national production. Oil was produced primarily in the Other region, and the Energy

Figure 4.2

Total Domestic Resource Extraction, 2010
Petajoules

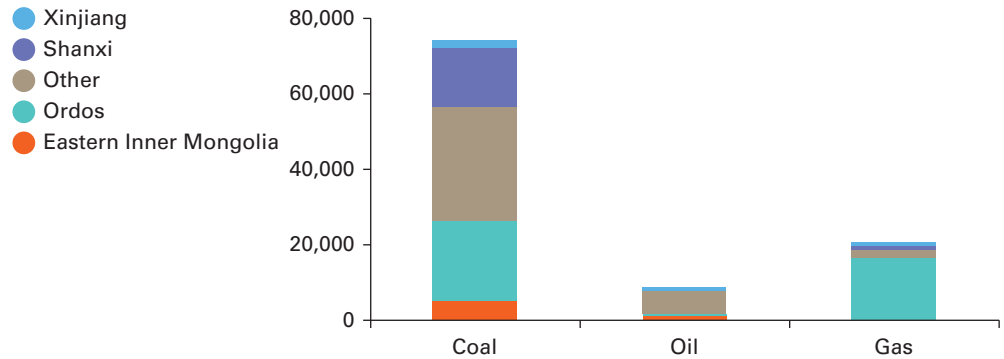

Source: National Bureau of Statistics 2011.

Bases accounted for 29.4 percent of the total. Natural gas was produced largely in Ordos, with the Energy Bases producing 89.4 percent of the national total. Coal can be extracted in the Energy Bases and shipped to the Other region for use with once-through or recirculating cooling, but the cost of transportation and the CO₂ limit policy makes this unattractive.

Power Plants

Table 4.1 presents the regional power plant capacity, by type, in 2010, according to China's compiled power industry statistics and shows that around 81 percent of the current generation is located in the Other region (China Electricity Council 2011a, 2011b). However, much of the future capacity is expected to be located in the four Energy Bases.

Given that coal is the key power source and renewable energy is increasingly important, figure 4.3 provides a breakdown of the installed capacity in 2010 of coal plant types, by region, and figure 4.4 shows the breakdown of hydropower, wind, and nuclear, by region. Figure 4.5 shows the share of solar and wind capacity updated for the significant changes between 2010 and 2015. In 2015, solar PV systems and onshore wind in the Energy Bases made up 46 percent and 63 percent of their national total, respectively.

Table 4.1

Regional Power Plant Capacity, 2010

Gigawatts

Type	Region				
	Eastern Inner Mongolia	Ordos	Other	Shanxi	Xinjiang
<i>Hydropower</i>					
Large hydropower	0.19	4.36	126.85	1.54	1.26
Small hydropower	0.01	5.03	74.80	0.28	1.73
<i>Thermal</i>					
Ultra-super critical	2.00	9.95	81.61	4.23	0.21
Super critical	3.13	15.02	83.33	6.85	0.67
Subcritical	2.29	12.39	61.79	5.29	0.91
Super high pressure	3.49	11.75	73.28	7.55	3.92
High pressure	0.38	4.54	74.07	5.20	0.80
Wind	2.75	8.88	16.20	0.37	1.36
Nuclear	0.00	0.00	10.82	0.00	0.00
Solar	0.00	0.09	0.19	0.00	0.00
Total	14.24	72.01	602.94	31.31	10.86

Source: China Electricity Council 2011a, 2011b.

Figure 4.3

Coal Power Plant Capacity, 2010

Gigawatts

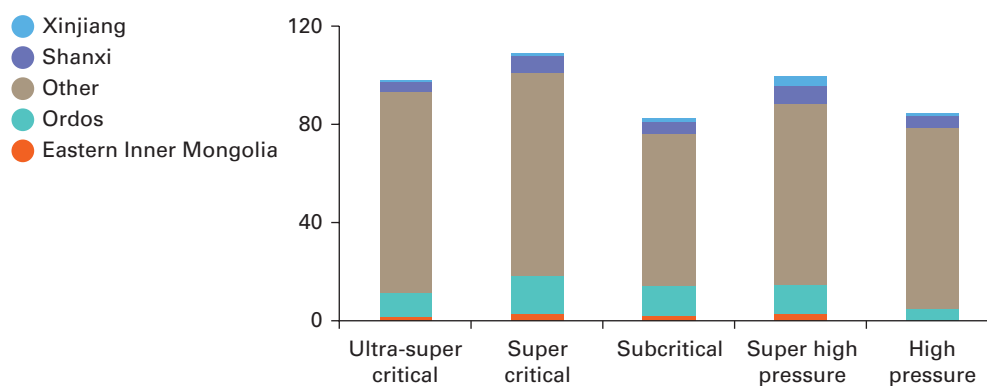

Source: China Electricity Council 2011b.

Figure 4.4

Hydro, Wind and Nuclear Power Plant Capacity, 2010
Gigawatts

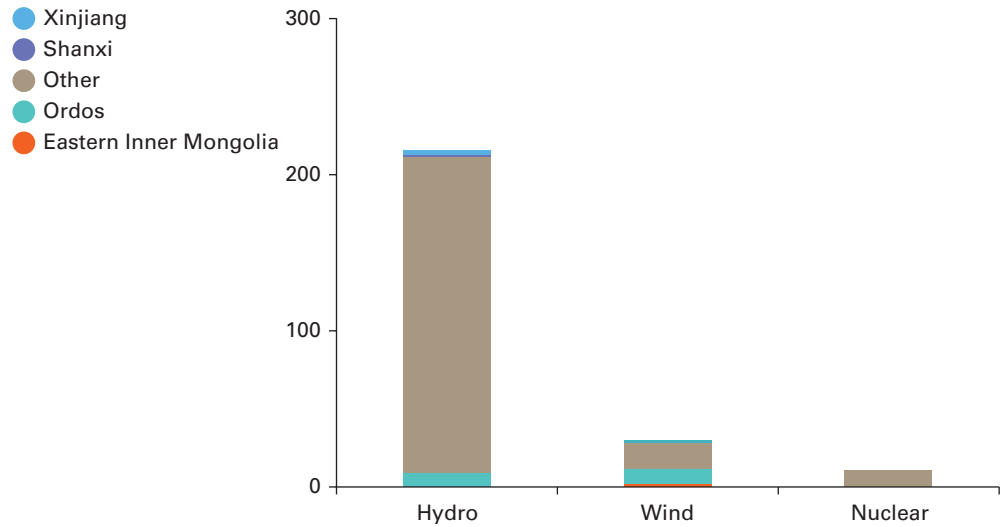

Source: China Electricity Council 2011b.

Figure 4.5

Capacity of Solar Photovoltaic and Wind, 2015
Gigawatts

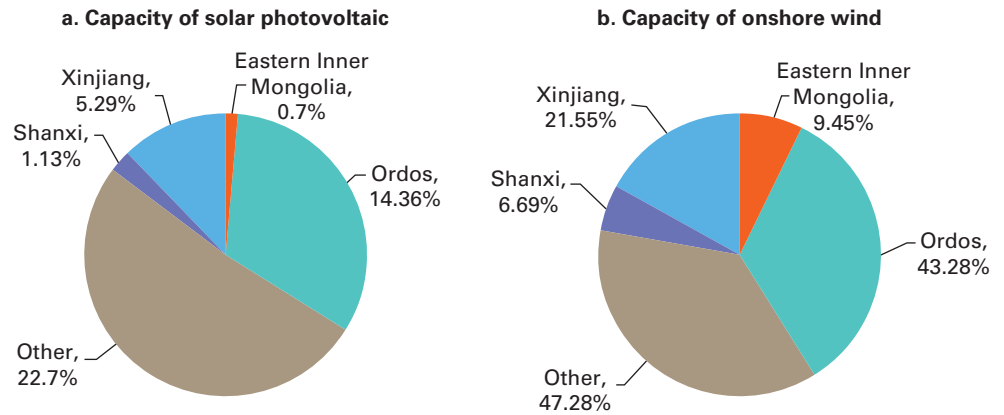

Source: China Electricity Council 2016.

The capacity of nuclear, concentrating solar power, and offshore wind are 26.40 GW, 0.01 GW, and 0.75 GW, respectively and are mostly in the Other region. The changing nature of the power plant mix, with decreasing coal and rapidly expanding Non-fossil generation, is clearly seen in the discussion of the Reference scenario (for example, see figure 7.10).

Coal Chemical

The coal chemical industry converts coal to liquid or gaseous energy carriers. In previous years, China had considered an aggressive program to promote the coal chemical industry to enhance its energy security. However, as table 4.2 shows, only modest levels of coal chemical industry materialized, primarily because of environmental concerns and economic reasons (see the “Coal Chemical Industry” section in appendix C).

Table 4.2 Coal Chemical Industry Capacity, 2010 and 2015

Facility Type	Unit	2010	2015	Location
Coal to liquid directly	Thousand tons per annum	1,080	1,080	Ordos
Coal to liquid indirectly	Thousand tons per annum	16	116	Ordos
Coal to gas	Billion cubic meters per annum	16	16	Shanxi
		0	1.33	Eastern Inner Mongolia
		0	1.375	Xinjiang
		0	0.4	Ordos

05

**Water
Modeling**

Methodology

The coal sector is one of the major water users in China, from mining and washing coal to cooling power plants. To sustainably develop the coal industry, water resources supply security is necessary. Because the majority of coal resources are located in the already water-stressed parts of northern China, the development of the northern Energy Base could face water resources constraints.

Considering the scale of water conservancy projects, water supply distances, and regional policies, energy security depends not only on water quantity but also on the cost of water supply. Moreover, the impact of climate change on regional water resources, could affect the development and management of the energy sector. A water-smart energy system model requires matching the energy options with their respective available water supply.

In this study, the water demands and water supply costs from different water sources are analyzed based on the existing comprehensive water resources plans in the four northern Energy Bases. The analytical method for water supply is described in appendix A. As discussed in appendix A, water for the energy sector in the future is determined by apportioning a share of the total projected available water in each region consistent with the current distribution. In addition, the energy sector has the option to purchase limited amounts of water rights from the non-energy (agriculture) sector. The price of the water is determined based on the assumption that there will be full cost recovery for each new water supply scheme, which is also presented in appendix A.3.

This chapter describes how the water demands forecast for the 2020–50 time frame were developed and shows the approach used to develop the unit water supply cost (UWSC) and the water supply cost curve (WSCC) for each region. In each region, the approach is based on detailed knowledge of the total current water use and water structure of different industries in the Energy Bases, the water resources conditions, the status of the water supply infrastructure, and the potential effects on future water supply and cost, as figure 5.1 shows. Because the Other region is not considered water constrained, a simplified approach was used, where a low base cost for water is specified without a limit on supply.

The water supply in each region can be expanded by building new surface water supply and water diversion projects, exchanging water rights, recycling wastewater and using drainage water, among other means. Additional water supply to the energy sector depends on the specific projects planned for that region to meet the full water demand, including the other sectors.

Water supply costs are calculated based on the Regulation for Economic Evaluation of Water Conservancy Construction Projects released by the Ministry of Water Resources of the People's Republic of China in 2013 (Ministry of Water Resources, 2013). In appendix A, the water supply cost method is described.

The UWSC represents the incremental cost of water supply along with each additional water infrastructure scheme (project) that needs to be undertaken to deliver the

Figure 5.1

Simplified Research Routing for Water Modeling

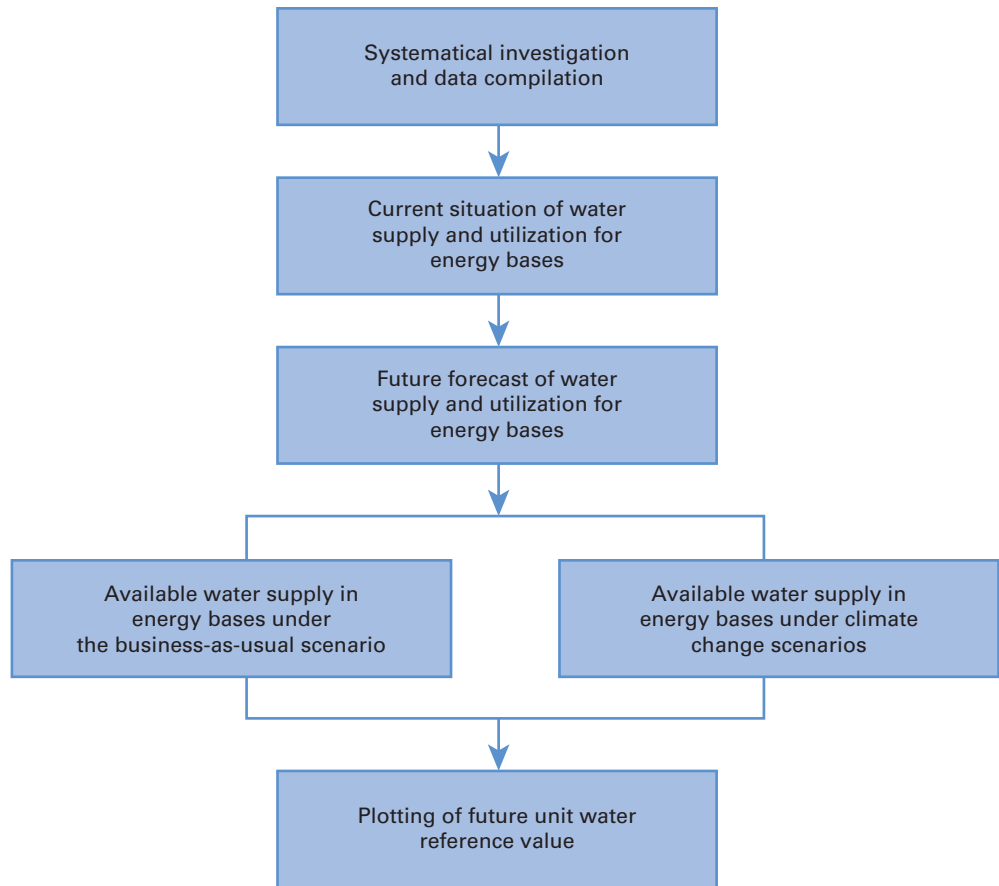

additional water. The UWSC is used to create the WSCC that is provided as input to TIMES-ChinaW by including the timing (year) in which each scheme could be introduced. TIMES-ChinaW then determines the marginal cost of water by climbing the WSCC to the level necessary to deliver that amount of water needed for energy, as an incremental amount above the assumed fixed non-energy demand for water. Different steps for supplying water (with upper limits and associated cost based on UWSC) are set up in TIMES-ChinaW. The water representation in TIMES-ChinaW is discussed with more detail in the “Water Representation in the TIMES-ChinaW Model” section in chapter 6. It is important to note that the water supply for hydropower plants in the Other region is not included in the WSCC.

Regional Water Resources

In terms of water, China's Energy Bases vary significantly in their regional locations and river basins. Because the Energy Bases have differing water distribution features, each is analyzed independently.

Table 3.1 describes China's main Energy Bases and their locations. The water aspects of each are discussed in the sections that follow. In addition to the main bases, an Other region represents the rest (the water-rich part) of the country, where the water resources conflict is not prominent in the process of energy development. Therefore, water use is not constrained in modeling the water-rich region, although the model does apply a unit cost for the water needed for energy there. The UWSC for the water-rich region is assumed to be 0.85 yuan/m³, with no upper bound.

Water in the Eastern Inner Mongolia Energy Base

The Eastern Inner Mongolia Energy Base encompasses mainly five large municipalities: Chifeng, Hulun Buir, Tongliao, Xilin Gol League, and Xingang, with a total area of 664.9 thousand square kilometers. The Eastern Inner Mongolia Energy Base is located in the northeast region of Inner Mongolia. Adjacent to the southeast area of the energy base are Hebei, Heilongjiang, Jilin, and Liaoning provinces and to the north are the Russian Federation and Mongolia.

The Eastern Inner Mongolia region has a cool and temperate continental monsoon climate, and its regional precipitation comes mainly from humid air from the Pacific summer winds. Because the region is located inland and isolated by the Da Hinggan Mountains, it infrequently experiences warm currents. Insufficient water vapor sources result in little annual precipitation that ranges from 265 to 442 mm, which decreases from the southeast to the northwest. Long hours of sunshine and significant winds in the region result in a very high evaporation rate. The geographic distribution of water surface evaporation, on the contrary, decreases from the northwest to the southeast.

Total water resources in the Eastern Inner Mongolia Energy Base are 48.53 billion m³. The current total water supply is 8.24 billion m³, including 2.59 billion m³ of surface water supply, 5.63 billion m³ of groundwater water supply, and 29 million m³ of others (see figure 5.2). In terms of usage, 5.10 billion m³ are used for agricultural irrigation; 1.17 billion m³ for industrial purposes (including 0.62 billion m³ for the energy sector); 1.08 billion m³ for urban water; and 893 million m³ for forest, fishery, and husbandry (see figure 5.3).

Figure 5.2

Composition of Total Water Supply in the Eastern Inner Mongolia Energy Base, 2012

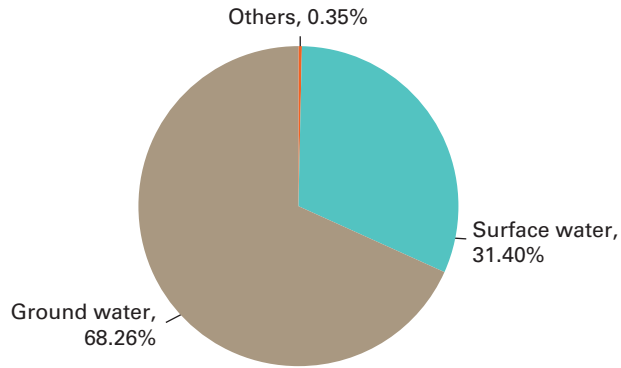
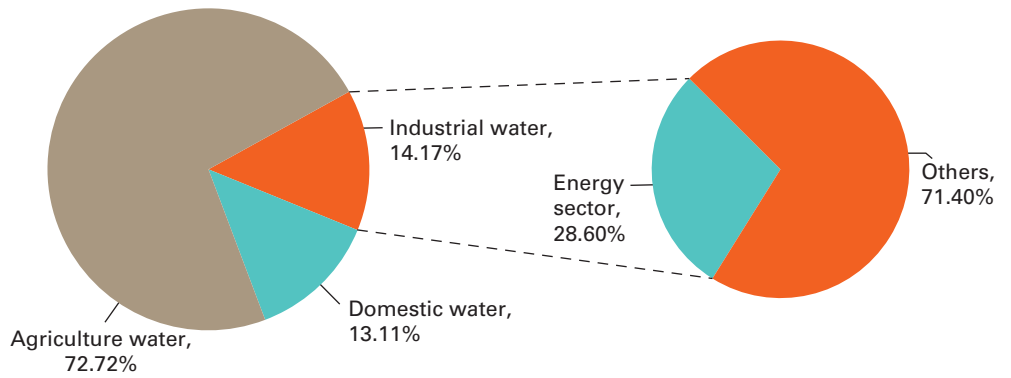

Figure 5.3

Composition of Total Water Use in the Eastern Inner Mongolia Energy Base, 2012



Water in the Ordos Energy Base

The Ordos Energy Base includes mainly four regions: Ordos, Ningdong, Shanbei, and Huanglong. It also includes four Ordos municipalities: Wuhai, Huhhot, Baotou, and Erdos; Yulin, Yan'an, Tongchuan, and Xianyang in Shaanxi Province; Yinchuan and Wuzhong in the Ningxia Hui Autonomous Region; and Pingliang and Qingyang in Gansu Province.

The Ordos Energy Base is located in the temperate drought continental climate zone, whose winter and summer precipitation varies greatly. Regional precipitation also differs as it decreases gradually from east to west. For example, annual precipitation in Xianyang and Tongchuan of Shanxi Province in the east ranges from 650 to 700 mm, whereas in Yinchuan and Wuzhong in the Ningxia Hui Autonomous Region in the west experience only 200 mm. With uneven seasonal distribution, precipitation is concentrated mostly in July, August, and September, accounting for 70 percent of total annual precipitation. Because of its uneven temporal-spatial precipitation distribution and significant evaporation, the Ordos Energy Base is a water-scarce area.

Total water resources in the Ordos Energy Base are 11.79 billion m³. The total current water supply of 9.94 billion m³, including 6.54 billion m³ of surface water, 3.18 billion m³ of groundwater, and 225 million m³ of other water sources (see figure 5.4). In terms of usage, 7.10 billion m³ of water are used for agricultural irrigation, 1.61 billion m³ for industrial purposes (including 1.30 billion m³ for the energy sector), and 628 million m³ for domestic purposes (see figure 5.5).

Figure 5.4

Composition of Total Water Supply in the Ordos Energy Base, 2012

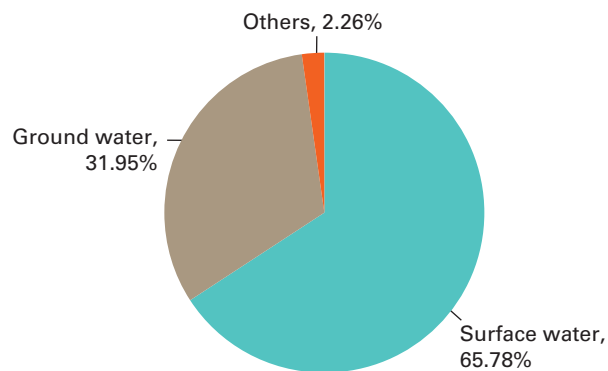
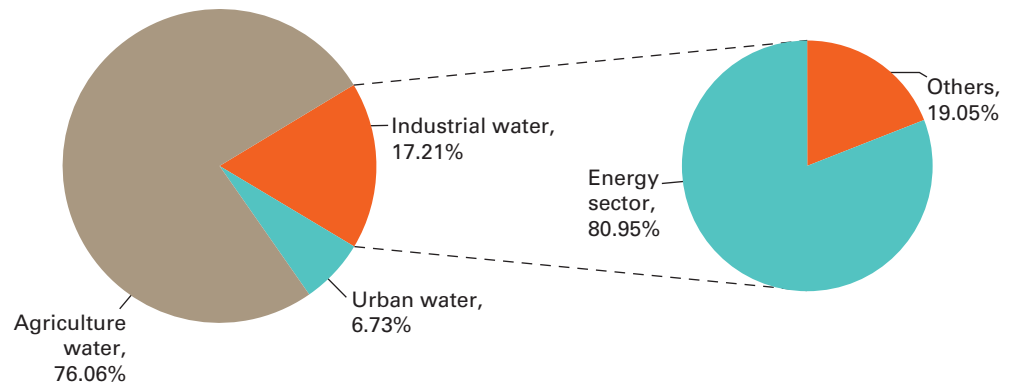

Figure 5.5

Composition of Total Water Use in the Ordos Energy Base, 2012



Water in the Shanxi Energy Base

The Shanxi Energy Base is located on the Loess Plateau on the western North China Plain and on the eastern bank in the middle reaches of the Yellow River, including mainly 11 cities in Shanxi Province.

Shanxi Province is located in mid-latitude inland on the eastern part of the continent. Bounded by the eastern mountains, its temperate continental monsoon climate is less affected by the sea. Its winters are long, dry, and cold. Summers are affected by maritime warm currents and the southeast monsoon, leading to concentrated precipitation. Precipitation increases from the northwest to the southeast with annual average precipitation ranging from 400 to 600 mm, and greater than 700 mm in parts of the mountainous areas.

Total water resources in the Shanxi Energy Base are 12.38 billion m³, with a total current water supply of 7.34 billion m³, including 3.18 billion m³ of surface water, 3.64 billion m³ of groundwater, and 514 million m³ of other water sources (see figure 5.6). In terms of usage, 3.99 billion m³ of water are used for agricultural irrigation, 1.55 billion m³ for industrial purposes (including 0.78 billion m³ for the energy sector), and 923 million m³ for domestic use (see figure 5.7).

Figure 5.6

Composition of Total Water Supply in the Shanxi Energy Base, 2012

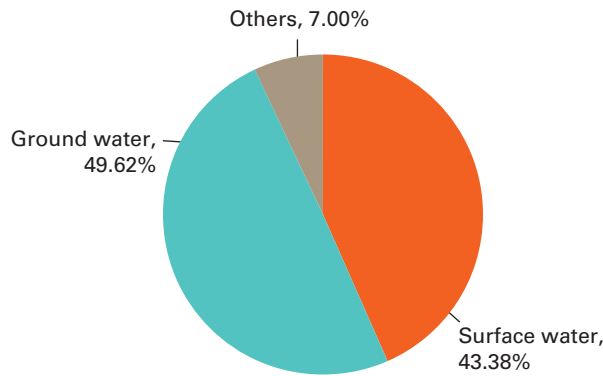
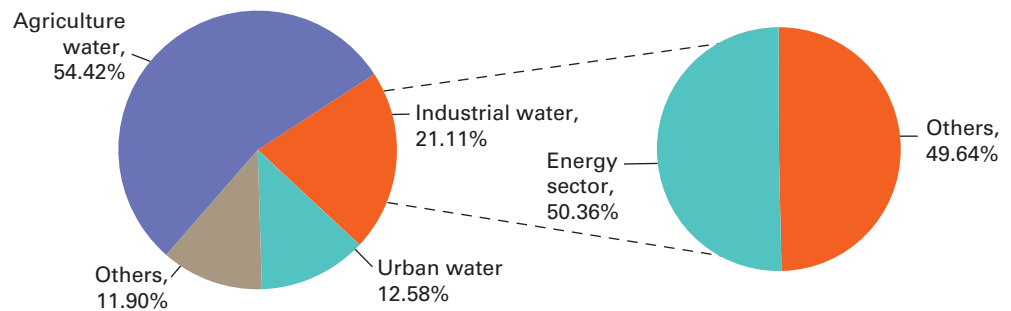

Figure 5.7

Composition of Total Water Use in the Shanxi Energy Base, 2012



Water in the Xinjiang Energy Base

The Xinjiang Energy Base includes the Xinjiang Uygur Autonomous Region. Its annual average precipitation is 254.40 billion m³, equivalent to water resources with a 154.8 mm depth, 23.8 percent of average precipitation depth across China. The general trend is that more precipitation occurs in the north than in the south, and more precipitation occurs in the west than in the east. Also, the evaporation capacity in mountains ranges from 800 to 1,200 mm and from 1,600 to 2,200 mm in the plains and basin.

The total water resources is 78.85 billion m³ in Xinjiang, with a total current water supply of 53.51 billion m³, including 43.92 billion m³ of surface water, 9.52 billion m³ of groundwater, and 70 million m³ of other water sources (see figure 5.8). In terms of usage, 48.46 billion m³ of water are used for agricultural irrigation, and 2.65 billion m³ for ecological and environmental purposes, 1.28 billion m³ for domestic purposes and 1.12 billion m³ for industrial purposes (including 0.27 billion m³ for the energy sector) (see figure 5.9).

Figure 5.8

Composition of Total Water Supply in the Xinjiang Energy Base, 2012

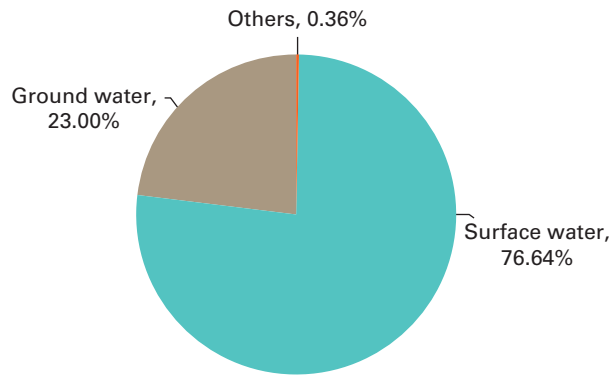
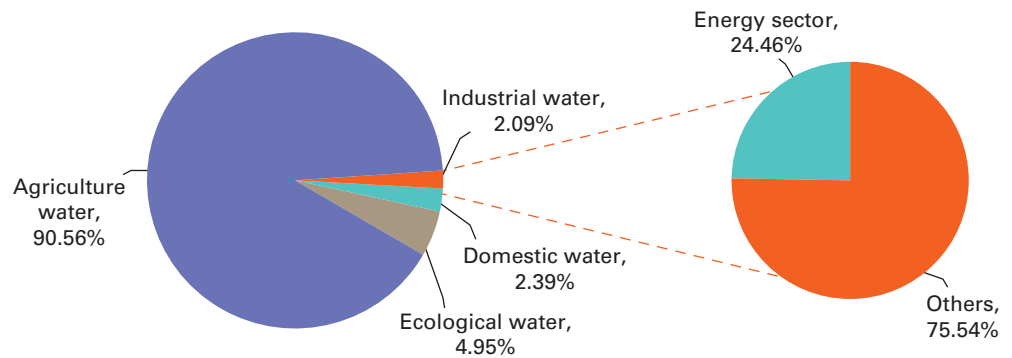

Figure 5.9

Composition of Total Water Use in the Xinjiang Energy Base, 2012



WSCC for the Energy Bases

According to integrated water resources planning and practical investigation in various areas, possible water supply capacity in the energy sector, and the corresponding water supply costs are analyzed for the 2020–50 period. The water supply levels mentioned in the sections that follow refer only to those for the energy sector. The UWSC data associated with each of the Energy Bases are reported in tables 5.1 through 5.4, for the business-as-usual (no climate change impacts) and representative concentration pathway (RCP) scenarios, this data becomes the WSCC once the project timing is imposed. These WSCCs reflect the water supply needs only for energy purposes based

on the current allocation of water to the various water consuming sectors, assuming this proportion remains similar over the planning horizon. There are two types of supply options: projects that add infrastructure (reservoir construction and water transfer projects) and conservation measures in the non-energy sectors that result in additional recycled water for energy production purposes.

The water transfer projects allow some flexibility for the model to indicate that consideration should be given to reallocation of water rights (for example, from agriculture to energy) should those options become available. A fuller representation of the non-energy water demands where water rights transfers and conservation possibilities compete with other supply options to meet both energy and non-energy water needs endogenously is a more robust way to handle this aspect of the nexus, which is discussed in the conclusions chapter.

WSCC for the Eastern Inner Mongolia Energy Base

The water supply capacity for energy in the Eastern Inner Mongolia Energy Base in the base year (2014) was 1.37 billion m³, which is expected to increase by 0.24 billion m³ by the year 2020. The energy sector depends mainly on surface water and reclaimed water supply projects. According to the Report of Integrated Water Resources Planning in Inner Mongolia (Inner Mongolia Water Resources Department 2012), a total of 83 million m³ of water supply capacity is expected to be added to the Eastern Inner Mongolia Energy Base through surface water project in the medium term and water reclamation projects in the long term. The total regional water supply capacity for the energy industry in 2050 is able to reach 2.43 billion m³.

Water supply costs are calculated based on Regulation for Economic Evaluation of Water Conservancy Construction Projects released by the Ministry of Water Resources of the People's Republic of China in 2013. The water supply cost method is provided in appendix A.

The UWSC data for the Eastern Inner Mongolia Energy Base is shown in figure 5.10 and summarized in table 5.1 for the BAU and RCPs scenarios. Figure 5.10 shows the incremental cost for each additional water infrastructure scheme (project) to deliver the additional water.

WSCC for the Ordos Energy Base

Water supply capacity for energy in the Ordos Energy Base in the base year was 5.01 billion m³. The water supply capacity is expected to be increased by 0.63 billion m³ by the year 2020. Developing new projects for surface water supply and water diversion will enable new water supply, with a projected 591 million m³ of water supply capacity to be added through medium- and long-term water recycling projects after 2020. Regional total water supply capacity to the energy sector in 2050 is able to reach 11.55 billion m³. The basic UWSC data for the Ordos Energy Base is shown in figure 5.11 and summarized in table 5.2 for the BAU and RCPs scenarios.

Figure 5.10

Unit Water Supply Cost Curve of the Eastern Inner Mongolia Energy Base

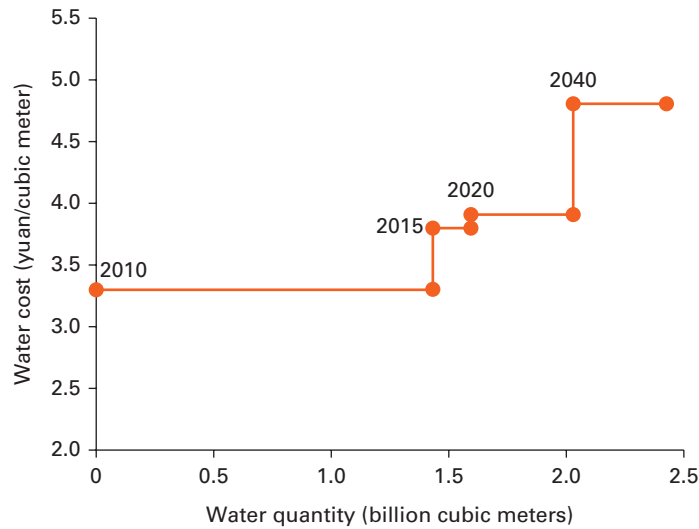

Table 5.1 Water Supply Options for the Eastern Inner Mongolia Energy Base, BAU, and RCPs

No.	Source	Starting year	Volume (billion m ³)				Price (yuan/m ³)			
			BAU	RCP2.6	RCP4.5	RCP8.5	BAU	RCP2.6	RCP4.5	RCP8.5
1	Existing reservoirs	2010	0.70	0.70	0.70	0.70	2.2	2.2	2.2	2.2
2	Recycled water (industry/urban)	2010	0.08	0.08	0.08	0.08	2.7	2.7	2.7	2.7
3	New reservoirs	2010	0.59	0.59	0.59	0.59	3.1	3.1	3.1	3.1
4	Recent reservoir construction project	2015	0.08	0.06	0.06	0.05	3.3	4.1	4.5	5.0
5	Mid-term recycled water	2020	0.16	0.16	0.16	0.16	3.8	3.8	3.8	3.8
6	Mid-term water diversion project	2020	0.43	0.30	0.38	0.33	3.9	4.6	4.4	4.7
7	Long-term recycled water	2040	0.40	0.40	0.40	0.40	4.8	4.8	4.8	4.8

Note. BAU = business as usual (no climate change impacts); m³ = cubic meter; RCP = representative concentration pathway.

Figure 5.11

Unit Water Supply Cost Curve of the Ordos Base

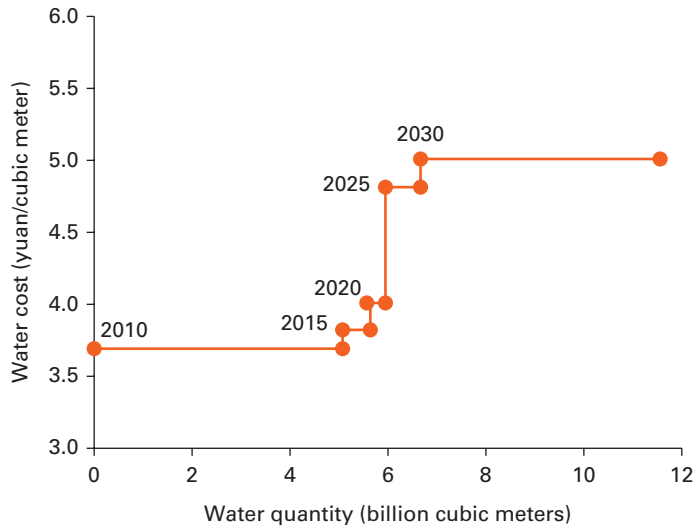

Table 5.2 Water Supply Options for the Ordos Energy Base, BAU, and RCPs

No.	Source	Starting year	Volume (billion m ³)				Price (yuan/m ³)			
			BAU	RCP2.6	RCP4.5	RCP8.5	BAU	RCP2.6	RCP4.5	RCP8.5
1	Existing reservoirs	2010	0.90	0.90	0.90	0.90	2.5	2.5	2.5	2.5
2	Recycled water (industry/urban)	2010	0.10	0.10	0.10	0.10	2.9	2.9	2.9	2.9
3	New reservoirs	2010	3.86	3.86	3.86	3.86	3.3	3.3	3.3	3.3
4	Recent reservoir construction project	2010	0.15	0.15	0.15	0.15	3.66	3.6	3.6	3.6
5	Water diversion project	2015	0.07	0.06	0.10	0.05	3.7	4.2	5.1	5.5
6	Mid-term water diversion project	2020	0.56	1.21	1.25	1.42	3.8	3.8	3.8	3.8

(continued)

Table 5.2 Water Supply Options for the Ordos Energy Base, BAU, and RCPs
(continued)

No.	Source	Starting year	Volume (billion m ³)				Price (yuan/m ³)			
			BAU	RCP2.6	RCP4.5	RCP8.5	BAU	RCP2.6	RCP4.5	RCP8.5
7	Mid-term recycled water	2025	0.32	0.32	0.32	0.32	4.0	4.0	4.0	4.0
8	Long-term recycled water	2030	0.72	0.72	0.72	0.72	4.8	4.8	4.8	4.8
9	Long-term water diversion project	2030	4.88	4.62	4.70	4.73	5.0	5.3	5.3	5.0

Note. BAU = business as usual (no climate change impacts); m³ = cubic meter; RCP = representative concentration pathway.

WSSC for the Shanxi Energy Base

Water supply capacity for energy in the Shanxi Energy Base in the base year was 1.42 billion m³. The water supply capacity is expected to increase by 0.30 billion m³ by the year 2020, with another 0.59 billion m³ of water supply capacity to be added by building water diversion projects, reservoir projects, and reclaimed water projects after 2020. Regional total water supply capacity for the energy sector in 2050 is projected to reach 2.31 billion m³. The UWSC data for the Shanxi Energy Base is shown in figure 5.12 and summarized in Table 5.3 for the BAU and RCPs scenarios.

WSSC for the Xinjiang Energy Base

Water supply capacity in the Xinjiang Energy Base in the base year was 1.15 billion m³. Additional water supply is expected to be achieved by building new projects, with 1.42 billion m³ of water supply capacity to be added through water diversion projects, reservoir projects, and reclaimed water projects after 2020. Backbone water diversion projects are built to divert water from the Yili River and the Eerqisi River to ensure that the regional energy base receives the water it needs. The total water supply for the energy sector in 2050 is expected to be 2.68 billion m³. The UWSC for the Xinjiang Energy Base is shown in figure 5.13 and summarized in table 5.4 for the BAU and RCPs scenarios.

Figure 5.12

Unit Water Supply Cost Curve of the Shanxi Base

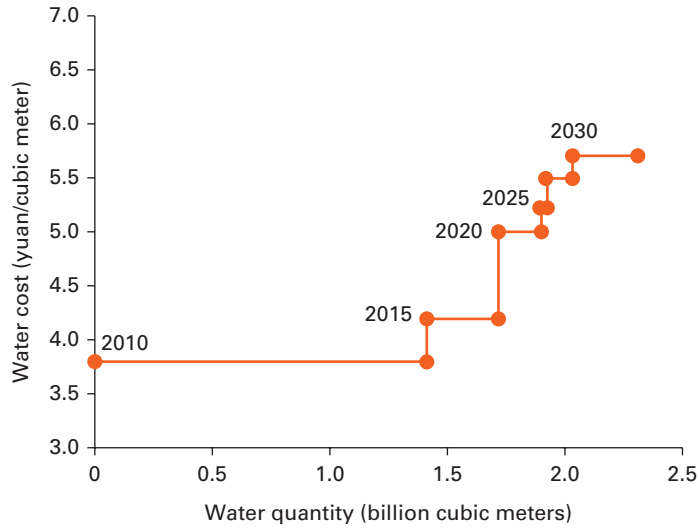

Table 5.3 Water Supply Options for the Shanxi Energy Base, BAU, and RCPs

No.	Source	Starting year	Volume (billion m ³)				Price (yuan/m ³)			
			BAU	RCP2.6	RCP4.5	RCP8.5	BAU	RCP2.6	RCP4.5	RCP8.5
1	Existing reservoirs	2010	0.65	0.65	0.65	0.65	2.8	2.8	2.8	2.8
2	Recycled water (industry/urban)	2010	0.02	0.02	0.02	0.02	2.9	2.9	2.9	2.9
3	New reservoirs	2010	0.04	0.04	0.04	0.04	3.0	3.0	3.0	3.0
4	Recent reservoir construction project	2010	0.30	0.30	0.30	0.30	3.3	3.3	3.3	3.3
5	Water diversion project	2010	0.41	0.41	0.41	0.41	3.8	3.8	3.8	3.8
6	Mid-term recycled water	2020	0.30	0.30	0.30	0.30	4.2	4.2	4.2	4.2

(continued)

Table 5.3 Water Supply Options for the Shanxi Energy Base, BAU, and RCPs
(continued)

No.	Source	Starting year	Volume (billion m ³)				Price (yuan/m ³)			
			BAU	RCP2.6	RCP4.5	RCP8.5	BAU	RCP2.6	RCP4.5	RCP8.5
7	Mid-term water diversion project	2025	0.18	0.19	0.13	0.18	5.0	4.3	4.8	4.8
8	Mid- and long-term reservoir construction project	2030	0.02	0.03	0.02	0.02	5.23	4.6	5.0	5.0
9	Long-term recycled water	2030	0.11	0.11	0.11	0.11	5.5	5.5	5.5	5.5
10	Long-term water diversion project	2035	0.28	0.28	0.27	0.27	5.7	5.8	5.6	5.6

Note. BAU = business as usual (no climate change impacts); m³ = cubic meter; RCP = representative concentration pathway.

Figure 5.13 Unit Water Supply Cost Curve of the Xinjiang Base

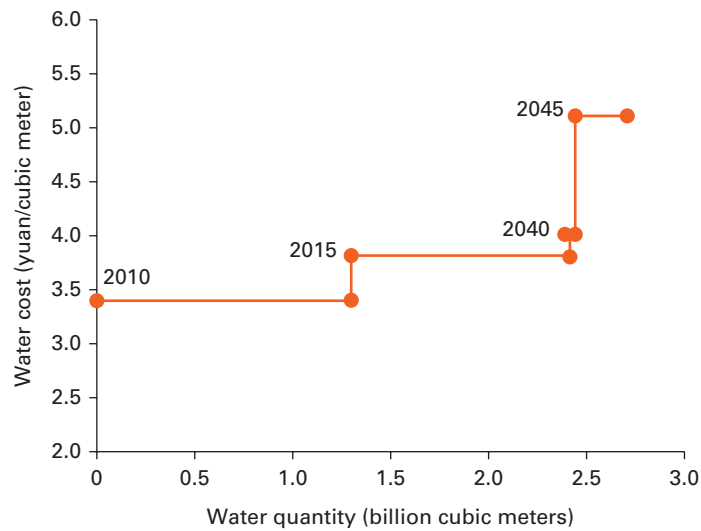

Table 5.4 Water Supply Options for the Xinjiang Energy Base, BAU, and RCPs

No.	Source	Starting year	Volume (billion m ³)				Price (yuan/m ³)			
			BAU	RCP2.6	RCP4.5	RCP8.5	BAU	RCP2.6	RCP4.5	RCP8.5
1	Existing reservoirs	2010	0.73	0.73	0.73	0.73	2.5	2.5	2.5	2.5
2	Recycled water (industry/urban)	2010	0.04	0.04	0.04	0.04	2.8	2.8	2.8	2.8
3	New reservoirs	2010	0.38	0.38	0.38	0.38	3.0	3.0	3.0	3.0
4	Recent reservoir construction project	2015	0.15	0.14	0.15	0.13	3.4	3.6	3.4	3.6
5	Mid-term recycled water	2040	1.11	1.32	1.65	1.51	3.8	3.8	3.8	3.8
6	Mid-term water diversion project	2045	0.04	0.04	0.04	0.04	4.0	4.0	4.0	4.0
7	Long-term recycled water	2045	0.27	0.27	0.27	0.27	5.1	5.1	5.1	5.1

Note. BAU = business as usual (no climate change impacts); m³ = cubic meter; RCP = representative concentration pathway.

Water Supply Cost Curves under Climate Change

Human activity increasingly affects the climate, particularly as the level of social and economic development improves. Studies show that fossil fuel burning in industry, transport, and buildings is a main reason for the increase of CO₂ and other greenhouse gases in the atmosphere, which contribute to climate change and may increase the frequency and intensity of extreme disasters such as floods and droughts, as well as directly affect levels of rainfall, evaporation, runoff, and soil moisture (Mauser and Bach 2009). Recent statistics indicate that climate change has already affected the water cycle characteristics in China (Zhang and others 2008).

The Climate Land Surface and Hydrology Model System (CLHMS), a model mainly used to conduct research on watershed level water resource changes, has been used to calculate the future water resources in order to analyze changes in water supply against the backdrop of climate change. The choice of Global Climate Model (GCM)

used for this case study is based on the model simulation abilities, temporal/spatial resolution and data availability. In consideration of the global climate models' simulation ability, the temperature and precipitation simulation capabilities of 14 global climate models in China during the twentieth century (1962–2005) were first examined. CNRM-CM5¹, HadCM3², and IPSL-CM5A-LR³ showed a better simulation capability in China. The spatial resolution of CNRM-CM5 (256×128) is higher than that of HadCM3 (96×73) and IPSL-CM5A-LR (96×96); as a result, the CNRM-CM5 was chosen as the GCM for the case study. All data required for the Climate Land Surface and Hydrology Model System and data available in CNRM-CM5 are provided in the appendix a, in table A.1.

This study adopts the IPCC-AR5 prediction experiment results for the twenty-first century driven by RCPs (Taylor, Stouffer, and Meehl 2012). According to China's medium- and long-term development plans and the world's developing level, three greenhouse gas emission scenarios were selected: RCP2.6 (low), RCP4.5 (mid), and RCP8.5 (high).

The IPCC-AR5 RCPs are named according to their 2100 radiative forcing level. The RCP 2.6 pathway represents a low greenhouse gas concentration scenario, and its radiative forcing level first reaches a value around 3.1 watts per square meter around 2050, then returns to 2.6 watts per square meter by the end of the twenty-first century (Van Vuuren and others 2011). The RCP 4.5 is a stabilization scenario where total radiative forcing is stabilized at 4.5 watts per square meter before 2100 (Thomson and others 2011). The RCP 8.5 is a high greenhouse gas concentration scenario, which is characterized by increasing greenhouse gas emission, the radiation forcing increases continuously to 8.5 watts per square meter in 2100 (Riahi and others 2011).

Although the Energy Bases, which belong to different river basins, are only part of the water consumption picture in each basin, it is important to understand the link between them and future water needs. Future water resource changes in the Yellow River Basin, the Haihe River Basin, and the Song-Liao River Basin are analyzed by simulations based on the Energy Bases in the river basin under different climate scenario settings. Details of the analytical method are described in appendix A.

Climate change affects precipitation, which affects regional water resources quantity and can thereby affect the project water supply capacity. Therefore, climate change can produce an indirect impact on the project cost of water supply. Figures from 5.14 to 5.17 show the WSCC for each of the Energy Bases under the BAU scenario and three climate change variants (RCP2.6/4.5/8.5). Tables 5.1 through 5.4 show the BAU and RCPs UWSC data. Note that the water delivery levels for the RCPs are the average for

¹ Voltaire A., E. Sanchez-Gomez, D. Salas y Méliá, B. Decharme, C. Cassou, S. Sénési, S. Valcke, I. Beau, A. Alias, M. Chevallier, M. Déqué, J. Deshayes, H. Douville, E. Fernandez, G. Madec, E. Maiconnave, M.-P Moine, S. Planton, D. Saint-Martin, S. Szopa, S. Tyteca, R. Alkama, S. Belamari, A. Braun, L. Coquart, F. Chauvin. 2013. The cnrm-cm5.1 global climate model: description and basic evaluation. *Climate Dynamics* 40 (9-10): 2091-121.

² Gordon, C., C. Cooper, C. A. Senior, H. Banks, J. M. Gregory, T. C. Johns, J. F. B. Mitchell, R. A. Wood. 2000. The simulation of sst, sea ice extents and ocean heat transports in a version of the hadley centre coupled model without flux adjustments. *Climate Dynamics* 16 (2-3): 147-68.

³ Persechino, A., J. Mignot, D. Swingedouw, S. Labetoulle, and E. Guilyardi. 2013. Decadal predictability of the atlantic meridional overturning circulation and climate in the ipsl-cm5a-lr model. *Climate Dynamics* 40 (9-10): 2359-80.

Figure 5.14

**Eastern Inner Mongolia Energy Base Water Supply Options
(Energy Sector Only)**

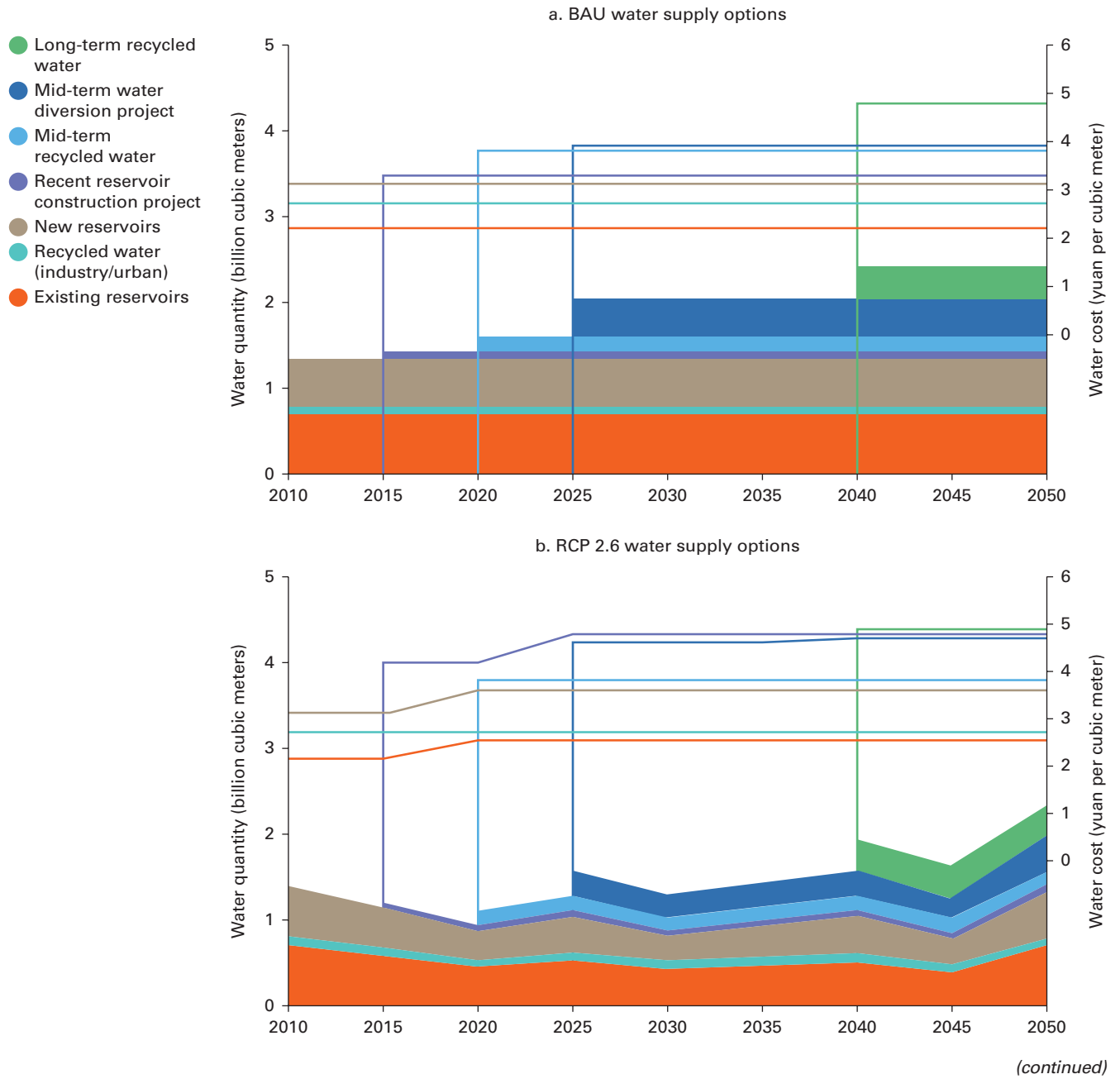
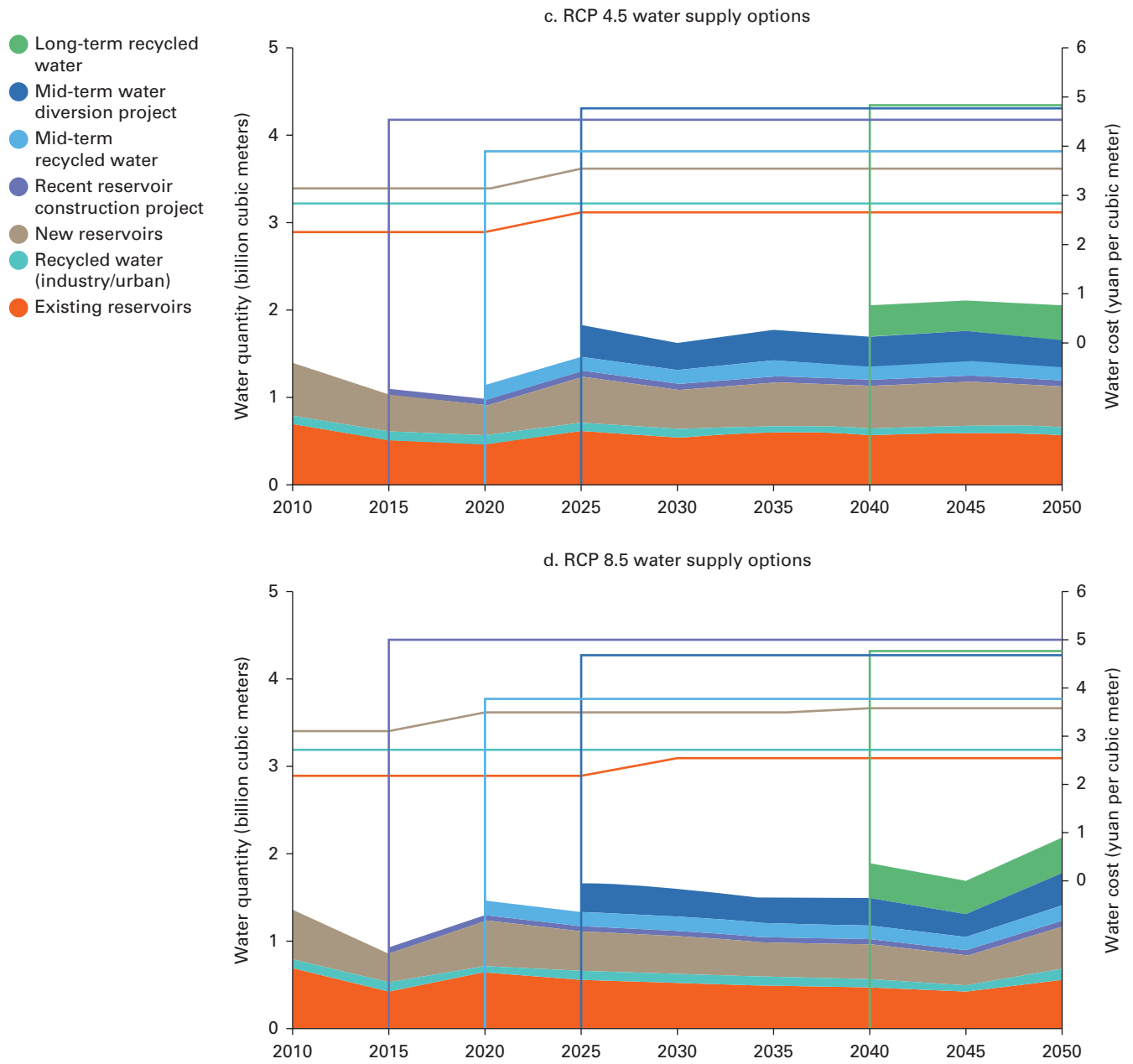

Figure 5.14

Eastern Inner Mongolia Energy Base Water Supply Options (Energy Sector Only) (continued)



Note: BAU = business as usual; RCP = representative concentration pathway.

Figure 5.15

Ordos Energy Base Water Supply Options (Energy Sector Only)

- Long-term water diversion project
- Long-term recycled water
- Mid-term recycled water
- Mid-term water diversion project
- Water diversion project
- Recent reservoir construction project
- New reservoirs
- Recycled water (industry/urban)
- Existing reservoirs

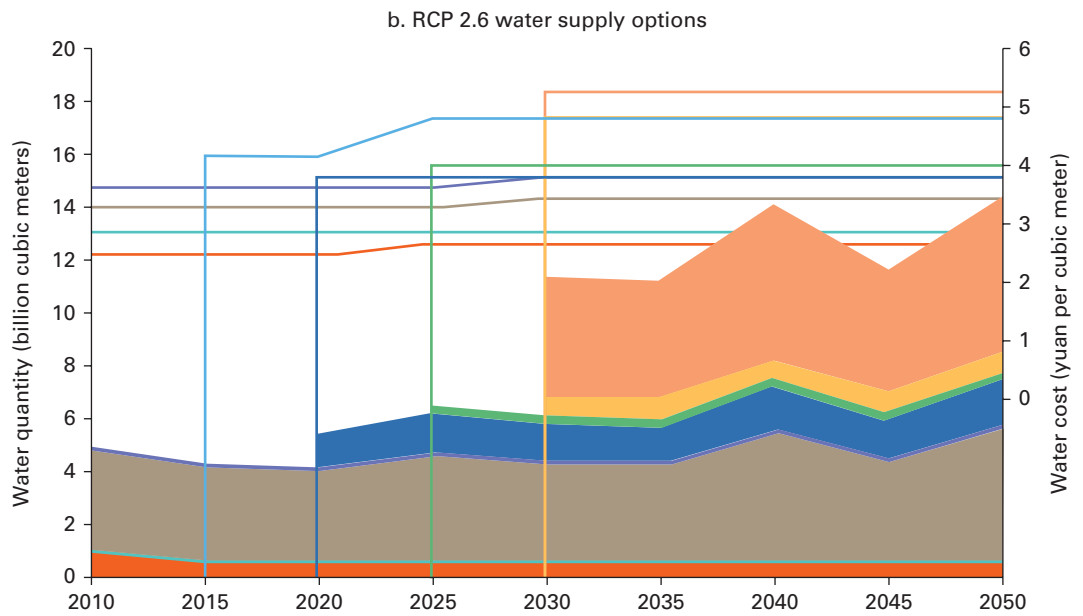
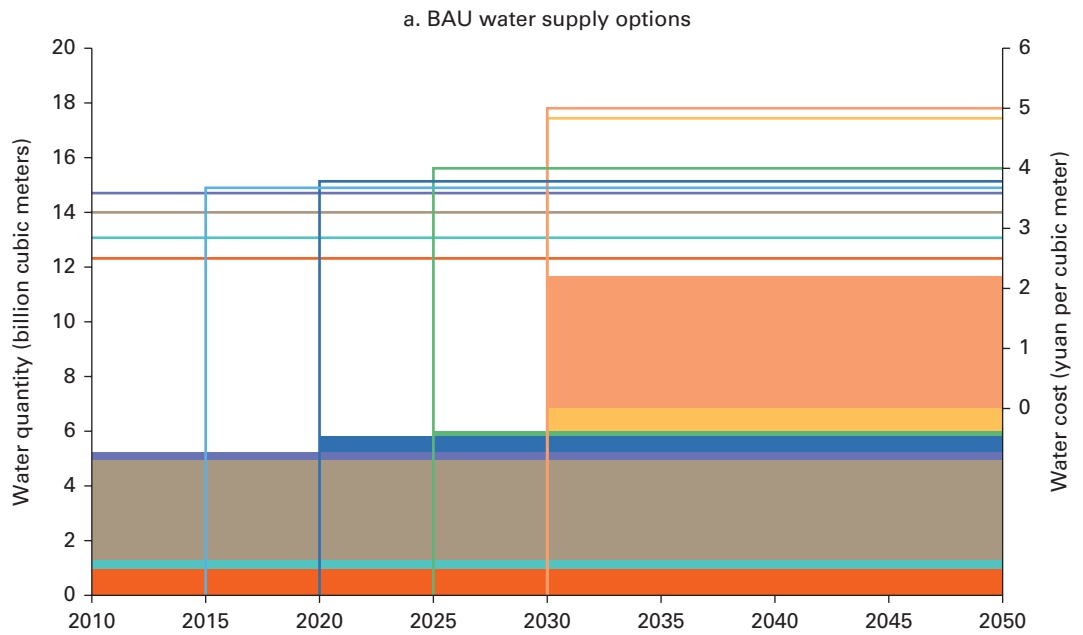

(continued)

Figure 5.15

**Ordos Energy Base Water Supply Options
(Energy Sector Only) (continued)**

- Long-term water diversion project
- Long-term recycled water
- Mid-term recycled water
- Mid-term water diversion project
- Water diversion project
- Recent reservoir construction project
- New reservoirs
- Recycled water (industry/urban)
- Existing reservoirs

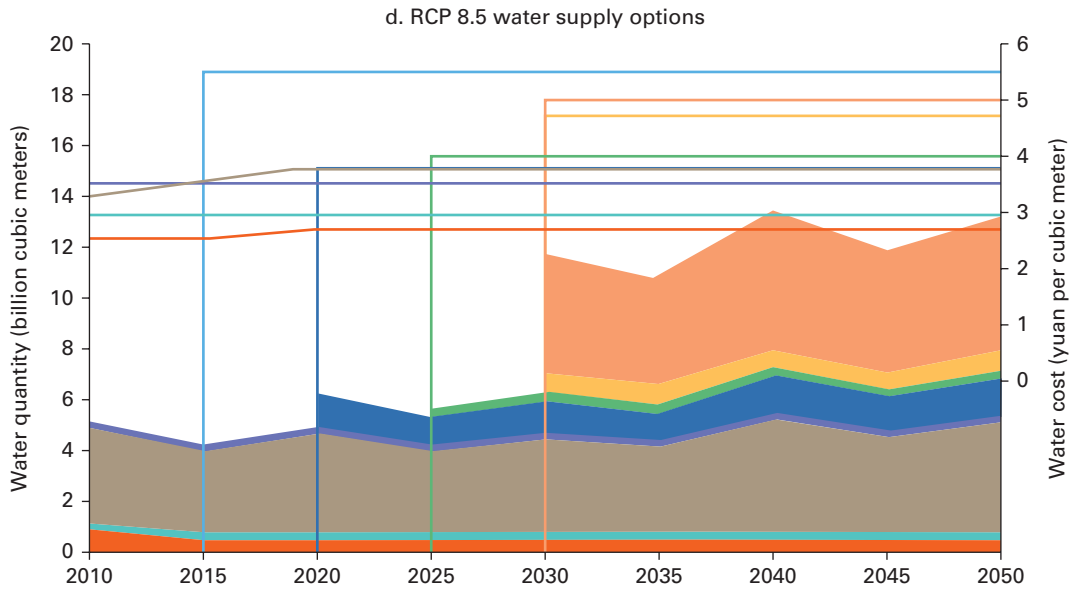
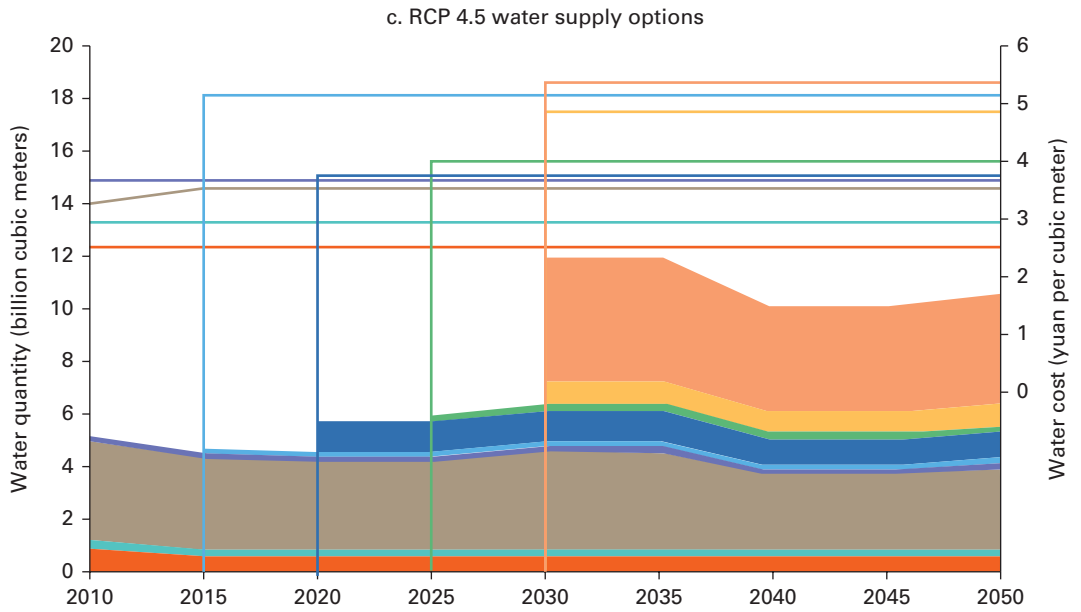

Note: BAU = business as usual; RCP = representative concentration pathway.

Figure 5.16

**Shanxi Energy Base Water Supply Options
(Energy Sector Only)**

- Long-term water diversion project
- Long-term recycled water
- Mid and water long term reservoir construction project
- Mid-term water diversion project
- Mid-term recycled water
- Water diversion project
- Recent reservoir construction project
- New reservoirs
- Recycled water (industry/urban)
- Existing reservoirs

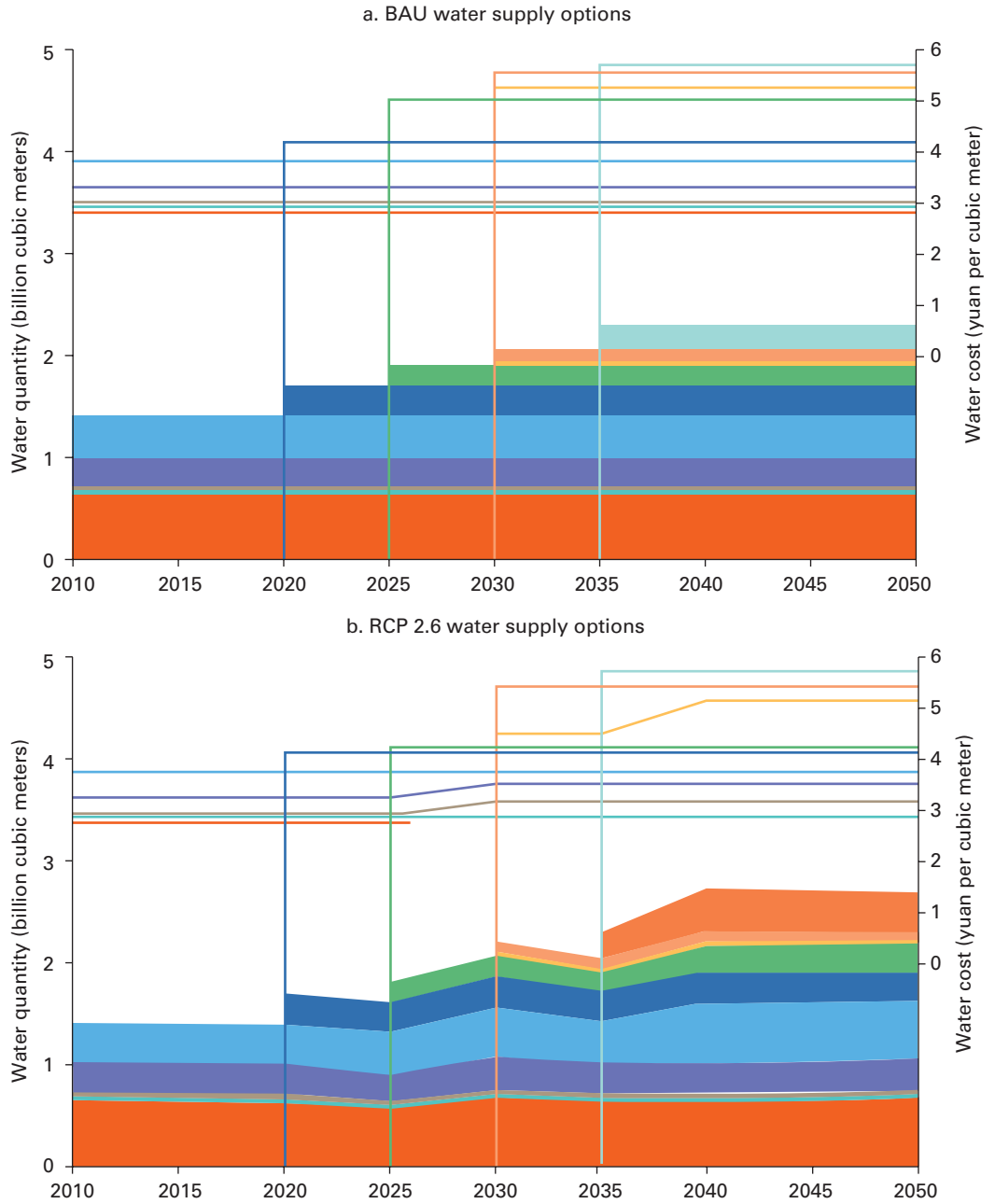

(continued)

Figure 5.16

**Shanxi Energy Base Water Supply Options
(Energy Sector Only) (continued)**

- Long-term water diversion project
- Long-term recycled water
- Mid and water long term reservoir construction project
- Mid-term water diversion project
- Mid-term recycled water
- Water diversion project
- Recent reservoir construction project
- New reservoirs
- Recycled water (industry/urban)
- Existing reservoirs

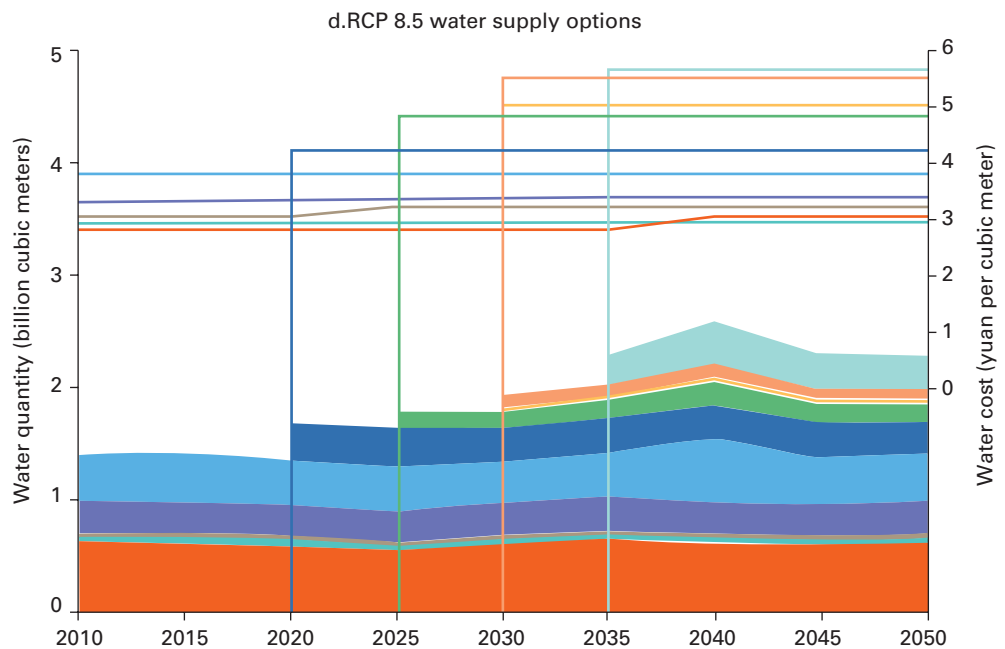
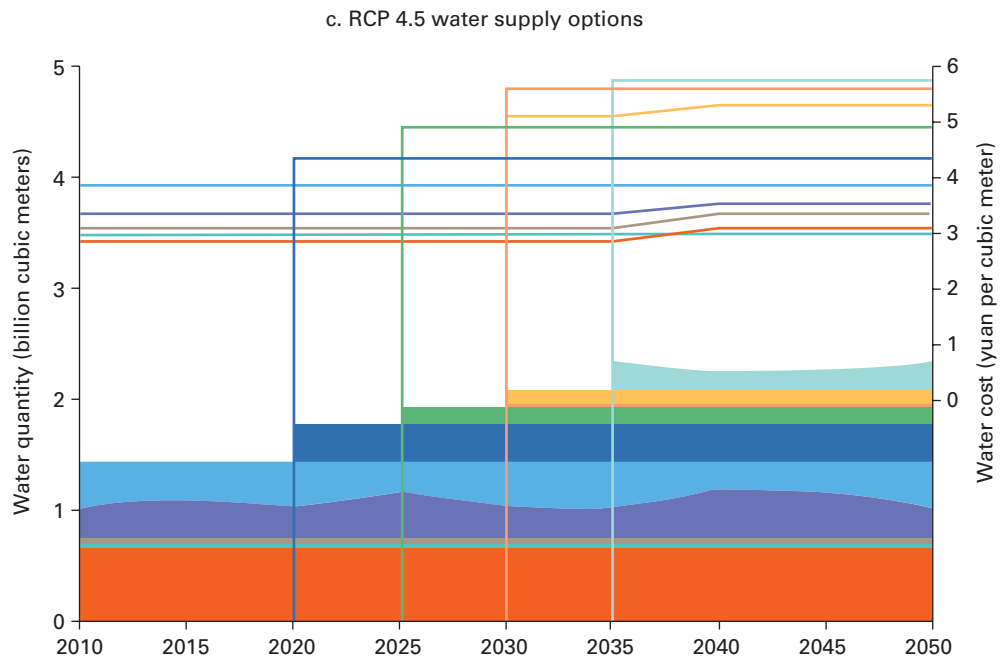

Note: BAU = business as usual; RCP = representative concentration pathway.

Figure 5.17

**Xinjiang Energy Base Water Supply Options
(Energy Sector Only)**

- Long-term water diversion project
- Mid-term water diversion project
- Mid-term recycled water
- Recent reservoir construction project
- New reservoirs
- Recycled water (industry/urban)
- Existing reservoirs

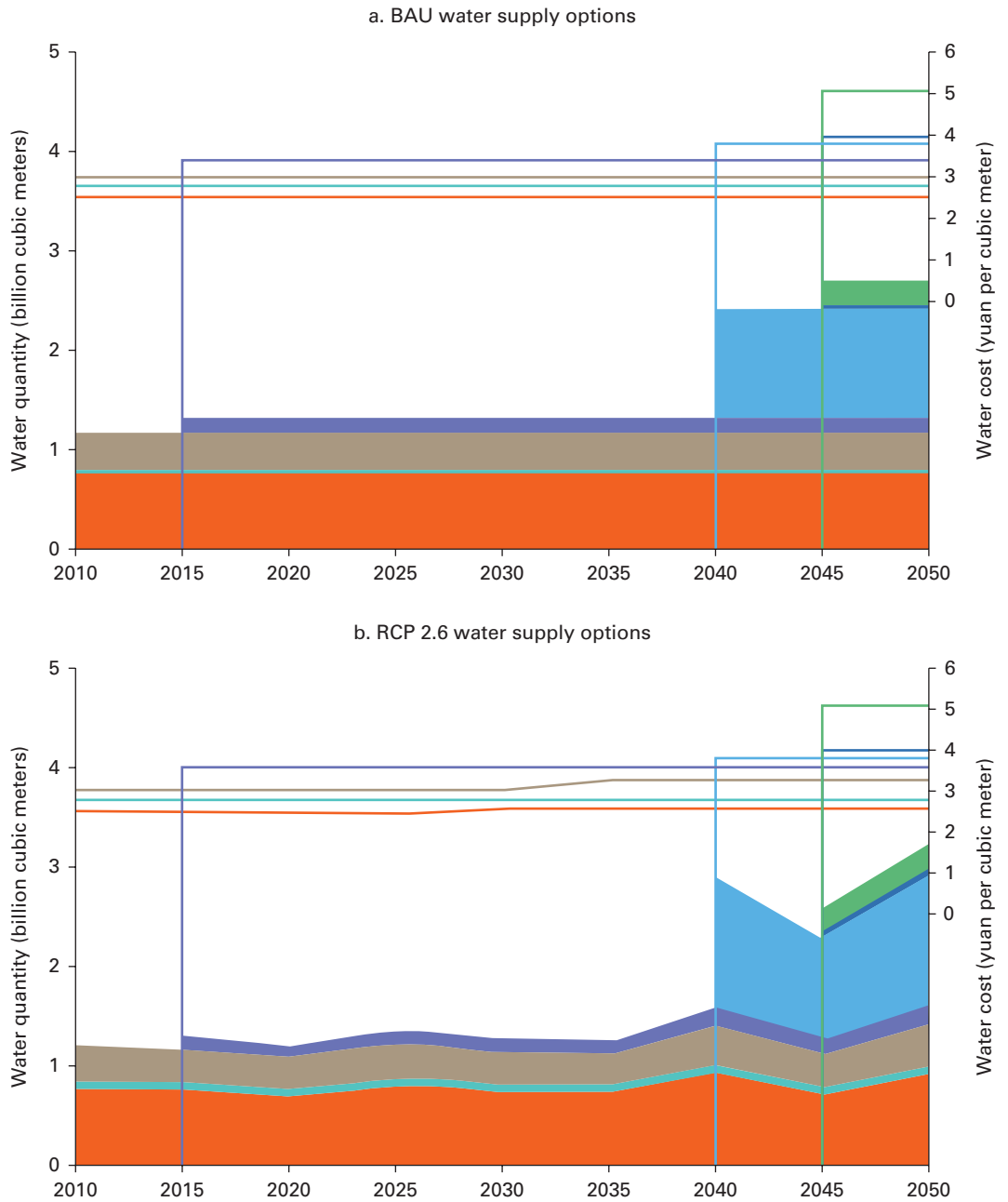

(continued)

Figure 5.17

**Xinjiang Energy Base Water Supply Options
(Energy Sector Only) (continued)**

- Long-term water diversion project
- Mid-term water diversion project
- Mid-term recycled water
- Recent reservoir construction project
- New reservoirs
- Recycled water (industry/urban)
- Existing reservoirs

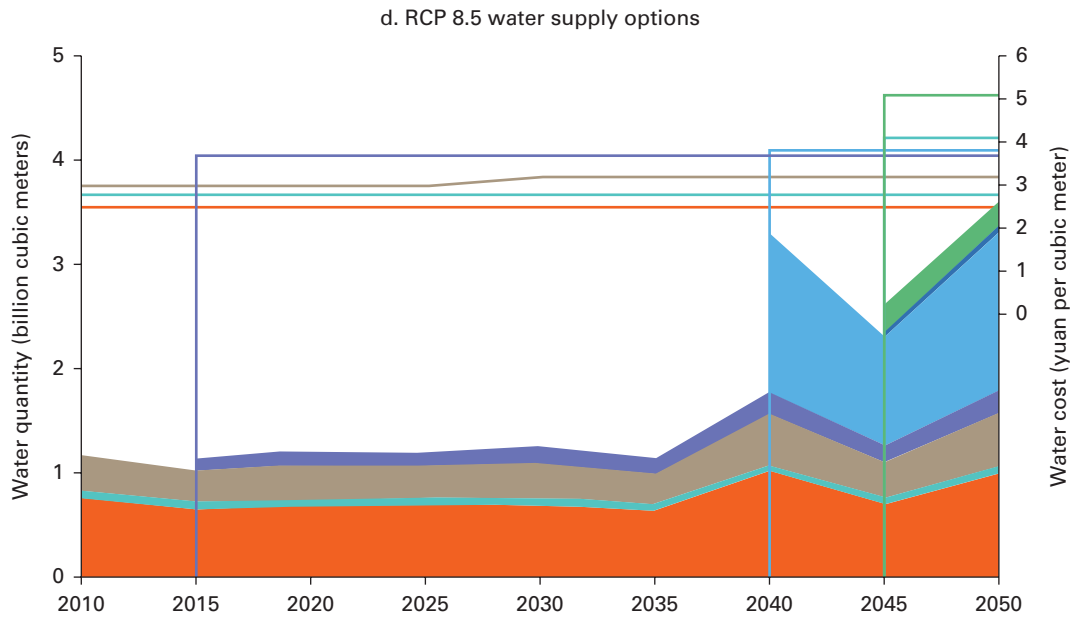
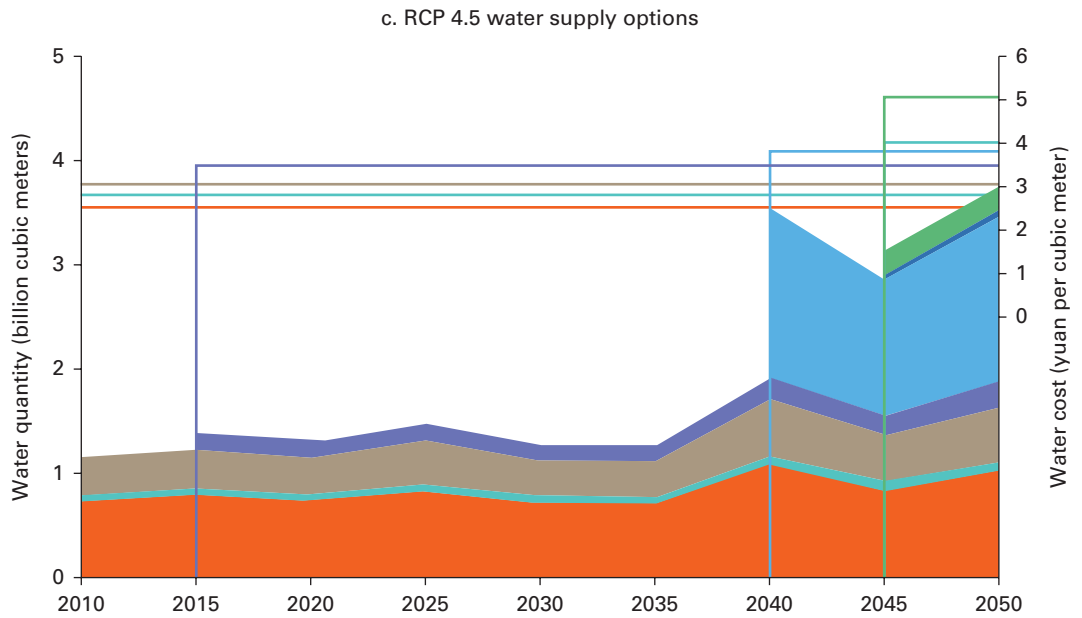

Note: BAU = business as usual; RCP = representative concentration pathway.

each project over the planning horizon because there are minor fluctuations over time. The impact of climate on different types of water supply schemes is not necessarily the same. Therefore, the WSCC is shown as a price and quantity supply step curve with 5-year intervals to 2050. These modified WSCC are used in the TIMES-ChinaW model to examine the water-energy nexus under climate change in China, as presented in chapter 7. Compared with the BAU scenario, the climate change scenarios show an increased variability of water resources. Consequently, the available water supply quantity for the Energy Bases also reflects the increases variability of water resources.

In the RCP2.6 scenario, local water resources in the Shanxi Energy Base will decrease slightly after 2020 from 0.29 to 0.27 billion m³, and the reservoir water cost will increase from 3.3 to 3.6 yuan/m³ around 2030. However, available water from water diversion projects will increase to 0.31 billion m³ after 2035. In 2050, the total water supply capacity will reach 2.69 billion m³. In the RCP4.5 scenario, the amount of local water resources fluctuates because of the construction of a recent reservoir project, where the amount of water diversion gradually decreases after 2035. The water supply capacity is 2.29 billion m³ by 2050. Compared with BAU scenario, the amount of local water resources and diversion water projects all gradually decrease after 2020 in RCP8.5 scenario. The water supply cost for a new reservoir increases from 3 to 3.2 yuan/m³ around 2025, and the cost of existing reservoirs increases from 2.8 to 3 yuan/m³ around 2040. The total water supply capacity in 2050 is 2.28 billion m³.

In the RCP2.6 scenario for the Ordos Energy Base, local water resources gradually increase after 2020, and the amount of diversion water projects will also increase around 2030. In 2050, the water supply capacity is 14.57 billion m³. In the RCP4.5 scenario, the total water supply capacity declines in 2040 because of the fluctuation of regional water resources. The water supply capacity is 1.09 billion m³ less than that in the BAU scenario. In the RCP8.5 scenario, compared with the BAU scenario, the local water resources gradually increases around 2020. However, the amount available from water diversion projects decreases. In 2050, the total water supply capacity will reach 13.37 billion m³.

In the RCP2.6 scenario for the Eastern Inner Mongolia Energy Base, the regional water resources remain stable from 2020 to 2045; after 2045, local water resources show an increasing trend. The water supply capacity in 2050 is 0.08 billion m³ less than that in the BAU scenario. In the RCP4.5 scenario, the amount of local water resources and diversion water change very little after 2025, and water cost also remains stable after 2025. The water supply capacity is 2.06 billion m³ in 2050. In the RCP8.5 scenario, the local water resources decrease in 2020–45; after 2045, the local water resource amount gradually increases. The water supply capacity around 2050 is 2.17 billion m³.

Water resources in the Xinjiang region show almost the same trend in all three climate change scenarios. Therefore, the WSCC for the Xinjiang Energy Base under the RCP2.6, RCP4.5, and RCP8.5 scenarios have the following similarities: the water supply capacity remains stable from 2020 to 2035, after which water resources fluctuate. The available water from reservoirs show a decrease around 2045. The water supply capacity in the RCP2.6, 4.5, and 8.5 scenarios are 3.24, 3.78, and 3.62 billion m³, respectively.

06

**Energy
Modeling**

To examine evolving energy issues in China, Tsinghua University had previously assembled a national MARKAL/TIMES model (for a general description, see the “Model Description” section in appendix B). Under the Thirsty Energy initiative, water supply and water demand by the energy sector are introduced into the existing energy system framework to create a water-smart energy model, the TIMES-ChinaW model. TIMES determines least-cost development pathways for the energy system under various conditions; and reports energy production and consumption, technology choices, investment in new energy production facilities and energy consuming devices, along with the associated air pollution and greenhouse gas emissions. To effectively use a TIMES model for policy analysis and planning purposes, two benchmark scenarios were established (one without China’s climate change policy [Base] and one with the climate change policies [Reference]). These two benchmark scenarios were used as the comparison point against which various alternative futures are evaluated.

Regional Consideration

The model is divided into five regions: the four Energy Bases and the Other region (as described in chapter 3). This study focuses on the resource extraction, electricity generation from power plants, and the coal chemicals industries, as well as the transportation of coal, gas, and electricity to meet national energy service demands. Figure 6.1 presents a simplified Reference Energy System for TIMES-ChinaW that depicts the flow of coal and electricity as well as where water is needed for energy through a series of transformation processes to meet the demand for energy services. Electricity also flows back to the mining and upstream processes; the flow of natural gas and any other commodity is similar. In addition, coal, gas, and electricity may move between the regions in the model.

Figure 6.2 presents the 2010 proportions of coal and natural gas transported and electricity transmitted from (or to) each region. Transportation refers to the net shipped in or out of the region. The coal transported to the Other region are mainly from Ordos and Shanxi, with a transportation cost imposed. Natural gas is transported from Ordos and Xinjiang to the Other region, and electricity is transmitted out of all four Energy Bases into the Other region. Table C.9 in the appendix C provides the transportation cost for each commodity.

Figure 6.1 Simplified TIMES-ChinaW Reference Energy System (RES)

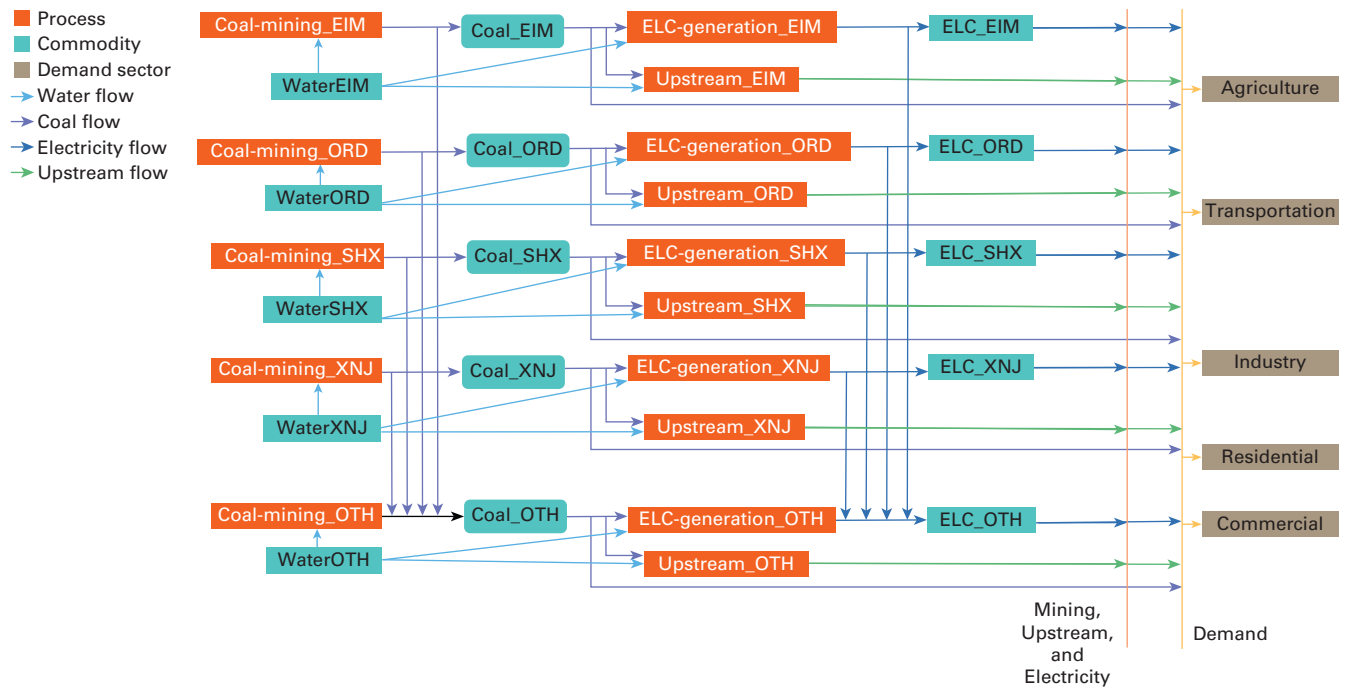
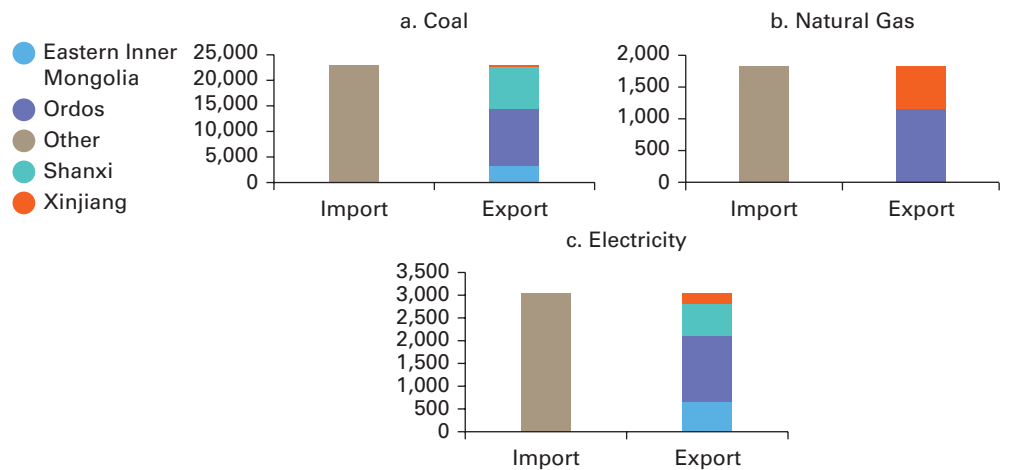

Figure 6.2 Transportation of Coal, Natural Gas, and Electricity, 2010
Petajoules



Water Representation in the TIMES-ChinaW Model

The TIMES-ChinaW model tracks water withdrawal for extraction of coal, oil, and gas; use by the coal chemical industry, and use by all types of power plants. The distinction between water withdrawal and water consumption is important. *Withdrawn water* is the water removed from surface or groundwater, at least temporarily, to produce or process energy, or for some other purpose. *Water withdrawals* are typically classified as either surface (from river, lakes, or impoundments) or groundwater. Water consumption is the portion of withdrawn water that is not returned to the surface or groundwater in the same drainage basin from which it was extracted. Consumed water is evaporated, transpired, and incorporated into products or crops, or otherwise removed from the water network. Because the data from the China Water Resource Bulletin present withdrawals, this research also focuses on water withdrawals. The principle of water use for energy can be explained by the following equations.

$$\text{Water Withdrawal} = \text{Water Consumption} + \text{Water Discharge}$$

such that

$$\text{Water Discharge} = \text{Treated Wastewater} + \text{Cooling Water}$$

and

$$\text{Water Consumption} = \text{Wastewater (which cannot be treated)} + \text{Loss (evaporation)}.$$

On the other hand, water use includes any part of water withdrawal that is recirculated for cooling, where water is continually reused being only topped off as needed to cover losses. Therefore, over the long term, water use is much bigger than water withdrawal, given the following:

$$\text{Water Use} = \text{Water Withdrawal} + \text{Amount for Recirculating} \cdot (N-1),$$

where N is the recirculating number.

In 2010, water withdrawals in China totaled about 602 billion m^3 (China Water Resources Bulletin), and the industry sector's share was 24.0 percent of the total, about 145 billion m^3 , among which the thermal power sector occupied approximately 32 percent at around 46 billion m^3 . Furthermore, the water demand has been increasing in the four Energy Bases in recent years. From 2005 to 2010, annual industrial water consumption grew by 8 percent in Eastern Inner Mongolia, 5 percent in Xinjiang, and 2 percent in Ordos. As China's energy demand continues to increase rapidly in water-scarce areas, the energy sector will increasingly need to plan with full consideration of water requirements, including an understanding of potential future constraints because of other competing uses and possible climate change. The lack of integrated planning could hamper China's rapid economic growth.

Figure 6.3 shows that the water consuming processes in each region of TIMES-ChinaW are organized according to extraction processes, power plants, and upstream energy supply processes. Where carbon capture and storage is shown as an option, said facilities may exist with or without carbon capture and storage.

Figure 6.3

Water Representation for Each Region in the TIMES-ChinaW Model

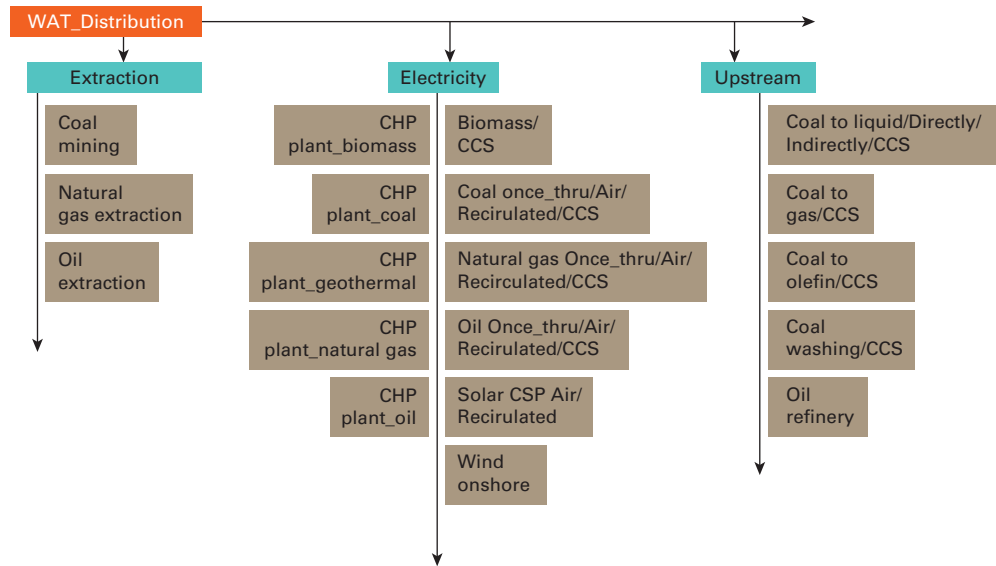

Note: CCS = carbon capture and storage; CHP = combined heat and power; CSP = concentrating solar power.

In this study, the energy sector configuration and the level of resource supply activity, along with the associated water withdrawal needs are endogenously determined by the optimization results of the TIMES-ChinaW model. The water withdrawal in the power sector is mainly affected by each technology’s activity level, fuel type, and cooling type, as equation (1) shows. Data on water withdrawal factors for different electricity generation technologies were gathered from various sources. Several selected technologies are shown in the “Water Factors for Other Energy-Related Activities” section in appendix C. Nuclear power plants are assumed to be located on costal sites and use seawater for cooling, so their water needs are not tracked in TIMES-ChinaW.

$$WW_{Elc,t} = \sum_{\phi} \sum_{\epsilon} (Elc_{\phi,\epsilon,t} \times wc_{\phi,\epsilon}) \tag{1}$$

where

$WW_{ELC,t}$ = water withdrawal in power sector in year t (m³);

$Elc_{\phi,\epsilon,t}$ = electricity production of technology ϕ , using cooling type ϵ (MWh), summed over all fuel types as well;

$wc_{\phi,\varepsilon}$ = water withdrawal factor of power generation technology ϕ , using cooling type ε (m^3 /MWh);

ϕ = type of power generation technology;

ε = type of cooling method, such as recirculating cooling, once-through cooling, and air cooling; and

t = time period.

The TIMES-ChinaW model optimizes the amount of electric generation from each kind of technology. The water withdrawal factor is the water needed to produce one unit of electricity. The water withdrawal factor is an external input and is kept constant during the model period.

The upstream sector is another important water user in China, and the water demand in this sector is also related to the activity level according to a water withdrawal coefficient. TIMES-ChinaW considers the following energy upstream technologies: coal mining and washing, oil and gas extraction, uranium extraction, coal-to-gas and coal-to-liquids processes, and oil refineries. Non-energy water uses and irrigation water for energy crops are not included in the analysis. The “Water Factors for Other Energy-Related Activities” section in appendix C gives the water withdrawal factors of several upstream processes. The water requirement in upstream sector is estimated according to equation (2).

$$WW_{UPS,t} = \sum_{\phi} P_{t,\phi} \times wc_{UPS,t,\phi}, \quad (2)$$

where

$WW_{UPS,t}$ = the water requirement in upstream sector in year t (m^3);

$P_{t,\phi}$ = the activity level of upstream technology ϕ in year t ;

$wc_{UPS,t,\phi}$ = the water withdrawal factor of upstream technology ϕ in year t ; and

ϕ = the type of technology, such as the coal mining and washing.

The activity of each upstream process is optimized by the model, whereas the water withdrawal factor is an external input and kept constant during the model period.

07

**Exploration
of China's
Future
Water-
Energy
Nexus**



©Yang Aijun / World Bank.

The TIMES-ChinaW model determines least-cost development pathways for the coupled water-energy system under various conditions. The model also reports energy production and consumption; technology choices; investment in new energy production facilities and energy-consuming devices; water infrastructure and operation requirements; associated air pollution; and greenhouse gas emissions. To effectively use a TIMES model for policy analysis and planning purposes, a viable comparison scenario needs to be established and used as the benchmark against which to evaluate various alternative future outcomes. The goal is to determine what set of policies or practices can best meet China's growing energy system needs.

For this analysis, two comparison scenarios were used: (1) the Base scenario, and (2) the Reference scenario. Both scenarios with and without considering the water supply cost are examined. In this chapter, first these two scenarios are compared to understand the impact of including water supply costs in an energy system. Then the different policy scenarios are compared against the Reference scenario. The Base scenario is also used to highlight more clearly the effect of individual policies independent of those embodied in the Reference scenario.

Base and Reference Scenarios

In TIMES-ChinaW, the Base scenario reflects the current status and the anticipated evolution of China's energy system in the absence of new policies. The Reference scenario

assumes that policies are implemented to meet the goals and commitments embodied in the 13th Five-Year Plan, particularly regarding the near-term energy sector investments and China's Nationally Determined Contribution submitted to the United Nations Framework Convention on Climate Change with respect to its CO₂ mitigation target. Both scenarios include the water supply cost for energy production. These then serve as points of comparison for the various alternative policies explored in the case study.

The key aspects of the energy system that serve as metrics to assess the broad effects of such policies are subsequently defined and used in this chapter. The change in these cumulative values provides a snapshot over the entire modeling horizon of the effect of the various scenarios for this case study. They are presented in table 7.1 for the Base and Reference scenarios in their aggregate for the entire 2010–50 planning horizon. The difference between the Base and Reference scenarios (with and without accounting for the cost of water) is discussed in the “Effect of Water Cost and Carbon Dioxide Policy” section later in this chapter. The key aspects used to compare the different scenarios are as follows:

- *Total discounted system cost*: the aggregated discounted costs including all investments in energy supply and generation technologies, investment and operating costs for water supply infrastructure as imbedded in the water supply cost curves (WSSC), purchases of demand devices in all sectors, operating and maintenance costs, and fuel expenditures, including delivery charges.
- *Primary energy*: the total amount of domestic production and imports by type.
- *Electricity generation*: the generation of electricity from all sources presented often by fuel and plant and cooling type.
- *New power plant capacity*: the addition of new power plants, with type and timing details.
- *Fuel expenditures*: Total annual expenditures for fuel including extraction and import and delivery costs.
- *Emissions*: Total CO₂ emissions from all sources, often broken out by fuel type or sector.
- *Water withdrawal*: The water withdrawal for the energy sector, often presented by type or region.

All costs reported are based on using a discount rate of 8 percent. The total discounted system cost and other cumulative 2010–50 metrics shown in table 7.1 provide the primary measure of the economic effect of potential policies in the Base and Reference scenarios.

Table 7.1**Base and Reference Scenario Cumulative Metrics, 2010–50**

Scenario	Unit	Base	Reference
System cost	Million dollars	34,739,126	35,643,752
Primary energy	petajoules	7,124,356	6,873,723
Electricity generation	Gigawatt-hour	402,222	415,254
Total water withdrawal	Billion cubic meters	333	320
Power plant new builds ^a	Gigawatt	4,071	5,895
Power plant investment	Million dollars	3,843,751	7,827,913
Fuel expenditures	Million dollars	42,987,780	38,534,897
CO ₂ emissions	Million Metric tons	535,730	410,664

Note: CO₂ = carbon dioxide.

a. The term new builds means the construction of new power plants or capacity additions.

Examining the Effects of Alternative Policies and Climate Change

To understand the implications of various future policy options including potential climate change impacts on the energy and water systems of China, 29 scenarios and individual measures in each scenario (see table 7.2) were developed. These scenarios were organized into four main groups: Base scenarios (without the CO₂ limit), Reference scenarios (with the CO₂ limit), Policy scenarios (with and without the CO₂ limit), and Combination scenarios. All scenarios include the current energy policies as noted under the Base in table 7.3. In each group, policies related to the cost of water supply, once-through cooling technology, and CO₂ limits were further examined.

As table 7.3 shows, some of these scenarios were further categorized by the specific policy issues that were addressed in the 13th Five-Year Plan: greenhouse gas mitigation (CO₂ limits), Non-fossil energy use, coal use, coal chemicals, and shale gas, which are examined separately and in combination with the CO₂ policy in the Reference scenario.

The results are presented according to the four clusters of scenarios and highlight specific differences between various policy options. Table 7.4 identifies these clusters and covers the most significant results including the effects of including water supply, the implementation of policies in the 13th Five-Year Plan, and possible interactions of climate change on the energy system evolution. However, not all of the scenarios are presented in the report because, for example, the Base scenarios without water costs did not show any variation from the Base scenarios with water costs scenario.

Table 7.2 Scenario Matrix
TIMES-ChinaW Case study Analysis Run Martrix

Case Name	Description	Cost or Water	rcp2.6	rcp4.5	rcp8.5	CO ₂ control	Renewable policy	Renewable plan	Coal control	Once through	Coal chemical plan	Shale gas plan
BAS-0	Base (no cost for water)											
BAS-01	Base (no cost for water)OT									Yes		
BAS-C	Base	Yes										
BAS-C1	Base OT	Yes								Yes		
BAS-rcp2.6	Base RCP2.6		Yes									
BAS-rcp4.5	Base RCP4.5			Yes								
BAS-rcp8.5	Base RCP8.5				Yes							
REFC-0	Reference (no cost for water)					Yes						
REFC-C	Reference	Yes				Yes						
REFC-rcp2.6	REF RCP2.6		Yes			Yes						
REFC-rcp4.5	REF RCP4.5			Yes		Yes						
REFC-rcp8.5	REF RCP8.5				Yes	Yes						
S_COPO	Coal Peak - No water cost No CO ₂								Yes			
S_NFPLAND	Non-fossil plan - No water cost No CO ₂							Yes				
S_NFPOLO	Non-fossil policy - No water cost No CO ₂						Yes					

(continued)

Table 7.2 Scenario Matrix (*continued*)

Case Name	Description	Cost or Water	rcp2.6	rcp4.5	rcp8.5	CO ₂ control	Renewable policy	Renewable plan	Coal control	Once through	Coal chemical plan	Shale gas plan
S_CCPO	Coal chemical- No water cost No CO ₂										Yes	
S_COP	Coal Peak - No CO ₂	Yes							Yes			
S_NFPLAN	Non-fossil plan - No CO ₂	Yes						Yes				
S_NFPOL	Non-fossil policy - No CO ₂	Yes					Yes					
S_CCP	Coal chemical - No CO ₂	Yes									Yes	
S_COPC	Coal Peak - with CO ₂	Yes				Yes			Yes			
S_NFPOLNC	Non-fossil plan - with CO ₂	Yes				Yes		Yes				
S_NFPOLC	Non-fossil policy - with CO ₂	Yes				Yes	Yes					
S_CCPC	Coal chemical - with CO ₂	Yes				Yes					Yes	
SALLC-0	ALL (no cost for water)					Yes		Yes	Yes		Yes	Yes
SALLC-C	ALL	Yes				Yes		Yes	Yes		Yes	Yes
SALLC-rcp2.6	ALL RCP2.6		Yes			Yes		Yes	Yes		Yes	Yes
SALLC-rcp4.5	ALL RCP4.5			Yes		Yes		Yes	Yes		Yes	Yes
SALLC-rcp8.5	ALL RCP8.5				Yes	Yes		Yes	Yes		Yes	Yes

Note: CO₂ = carbon dioxide; OT = once through; RCP = representative concentration pathway.

Table 7.3 Policy Issues Examined

Policy issue	Scenario name/model run ID ^a	Description
Current policies in 2015	Base/BAS	Industrial restructuring; elimination of backward electric generation capacity; improvement of energy efficiencies in different industries; development of renewable and nuclear energy
Current policies in 2015, plus greenhouse gas mitigation (in line with China's NDC)	Reference/REFC	Limit total CO ₂ emissions to 9.5 billion tons in 2020 and 11.0 billion tons in 2030
Non-fossil energy	Non-fossil plan/S_NFPLAN	Implement government plans to 2020 for nuclear and renewables extended until 2030
	Non-fossil policy/S_NFPOL	Implement government policy to achieve the goal, which is to raise the proportion of Non-fossil energy in primary energy consumption to about 20 percent by 2030
Coal use	Coal (peak)/S_COP	Limit coal production to 2.85 billion tons coal equivalent in 2020 and 1.5 billion tons coal equivalent in 2050
Coal chemicals	Coal (chemical)/S_CCP	Coal-to-liquid capacity increases to 2,400 Thousand tons per annum by 2020, and the coal-to-gas capacity grows to 3.1 billion m ³ per year by 2030
Combined scenarios	ALL/S_XALLCC	Combining base, Non-fossil plan, CO ₂ (peak), coal (peak), and including shale gas, which is 4.5 billion m ³ in 2015, and projected to be 30 billion m ³ in 2020 and 60 billion m ³ in 2030.

Note: CO₂ = carbon dioxide.

^aSuffice appended to run name - 0 no water costs / C water costs / 1 test once-through policy

Table 7.4 Scenario Clusters for Assessment

Analysis Cluster	Model Runs			
1. Effect of water cost and once-through cooling policy	BAS-0	BAS-01	BAS-C	BAS-C1
2. Effect of water cost and CO ₂ policy	BAS-0	BAS-C	REFC-0	REFC-C
3. Basic policies with CO ₂	REFC-C	S_COPC	S_NFPLANC	S_CCPC
4. Effect of climate change	REFC-0	REFC-rcp2.6	REFC-rcp4.5	REFC-rcp8.5

(continued)

Table 7.4**Scenario Clusters for Assessment (continued)**

Analysis Cluster	Model Runs			
5. Reference versus all: Effect of water cost	REFC-0	REFC-C	SALLC-0	SALLC-C
6. Basic policies with no water cost or CO ₂ policy	BAS-0	S_COP0	S_NFPOL0	S_CCP0
7. Basic policies with water cost and no CO ₂ policy	BAS-C	S_COP	S_NFPLAN	S_CCP
8. Non-fossil plan versus Non-fossil policy: Effect of climate change rcp4.5	REFC-C	S_NFPLANC	S_NFPOLC	REF-CP4.5
9. Reference versus All policies: Effect of climate change rcp8.5	REFC-C	REFC-rcp8.5	SALLC-C	SALLC-rcp8.5
10. All policies: Effect of climate change	SALLC-C	SALLC-rcp2.6	SALLC-rcp4.5	SALLC-rcp8.5

Note: CO₂ = carbon dioxide.

Effect of Water Cost and Once-Through Cooling Policy

As figure 7.1 shows, incorporating the cost of water significantly reduces power plant water withdrawal. By 2050, the reduction in annual water withdrawals is approximately 40 billion m³.

Figure 7.2 shows that in the absence of water supply costs, the policy restricting the use of once-through cooling systems has the effect of shifting about 60 gigawatts (GW) of coal-fired power plants from once-through to recirculating cooling by 2050. Including the cost of water supply results in a shift similar to imposing the policy, reflecting the economic rationale for the policy, with both cases shifting over 70 GW from once-through to air and recirculating cooling by 2050.

Figure 7.1

Power Sector Water Withdrawal: Effect of Water Supply Cost
Billion cubic meters

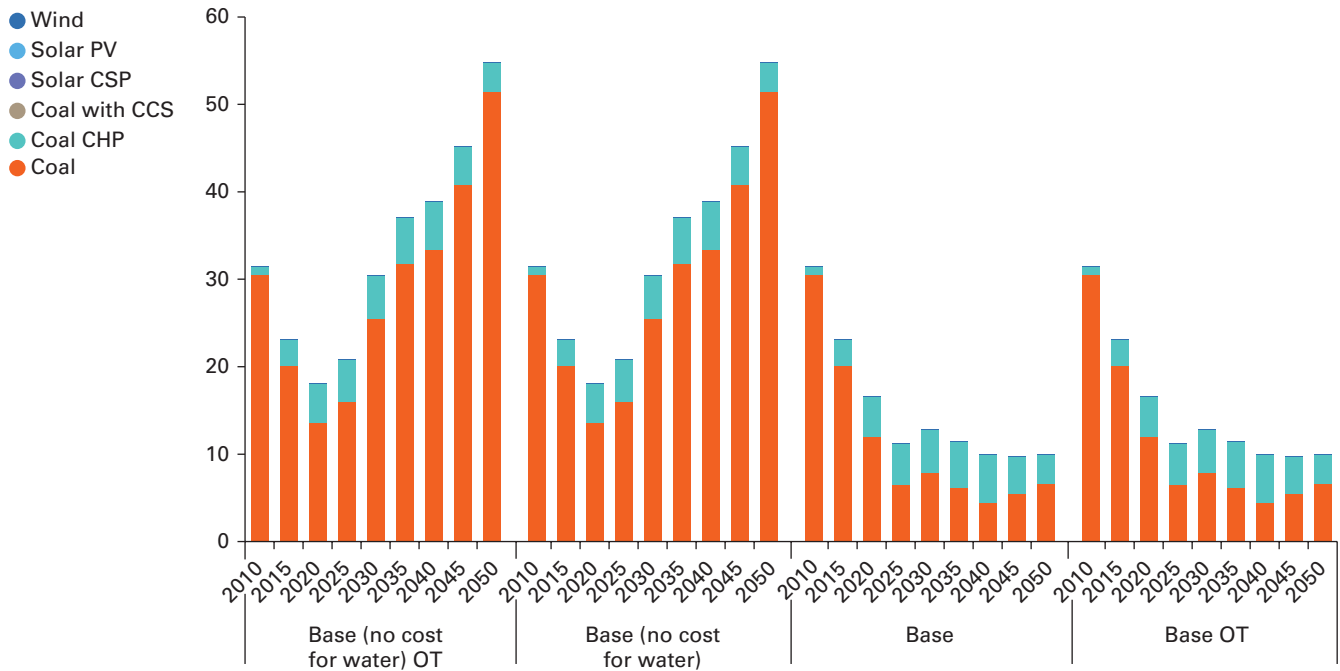

Note: CCS = carbon capture and storage; CHP = combined heat and power; CSP = concentrating solar power; OT = once through; PV = photovoltaic.

Adding the cost of water supply initially shifts a small portion of new power plant constructions away from natural gas and toward new coal plants, but in the latter periods wind displaces coal generation (see figure 7.3).

Figure 7.4, shows that introducing the cost and availability of water leads to a significant reduction in water use for electricity generation, as well as a significant reduction in water for upstream processes as the coal chemical industry is cut back. Figure 7.4 also shows that regionally, adding the cost of water shifts generation out of Shanxi, Ordos, and Xinjiang and to the Other region and to Eastern Inner Mongolia. These changes constitute only a few percentage points but demonstrate the importance of incorporating the role of water when modeling the energy sector in support of policy planning.

Figure 7.2

Coal Power Plant Capacity, by Cooling Type: Effect of Water Supply Cost Cluster

Gigawatts

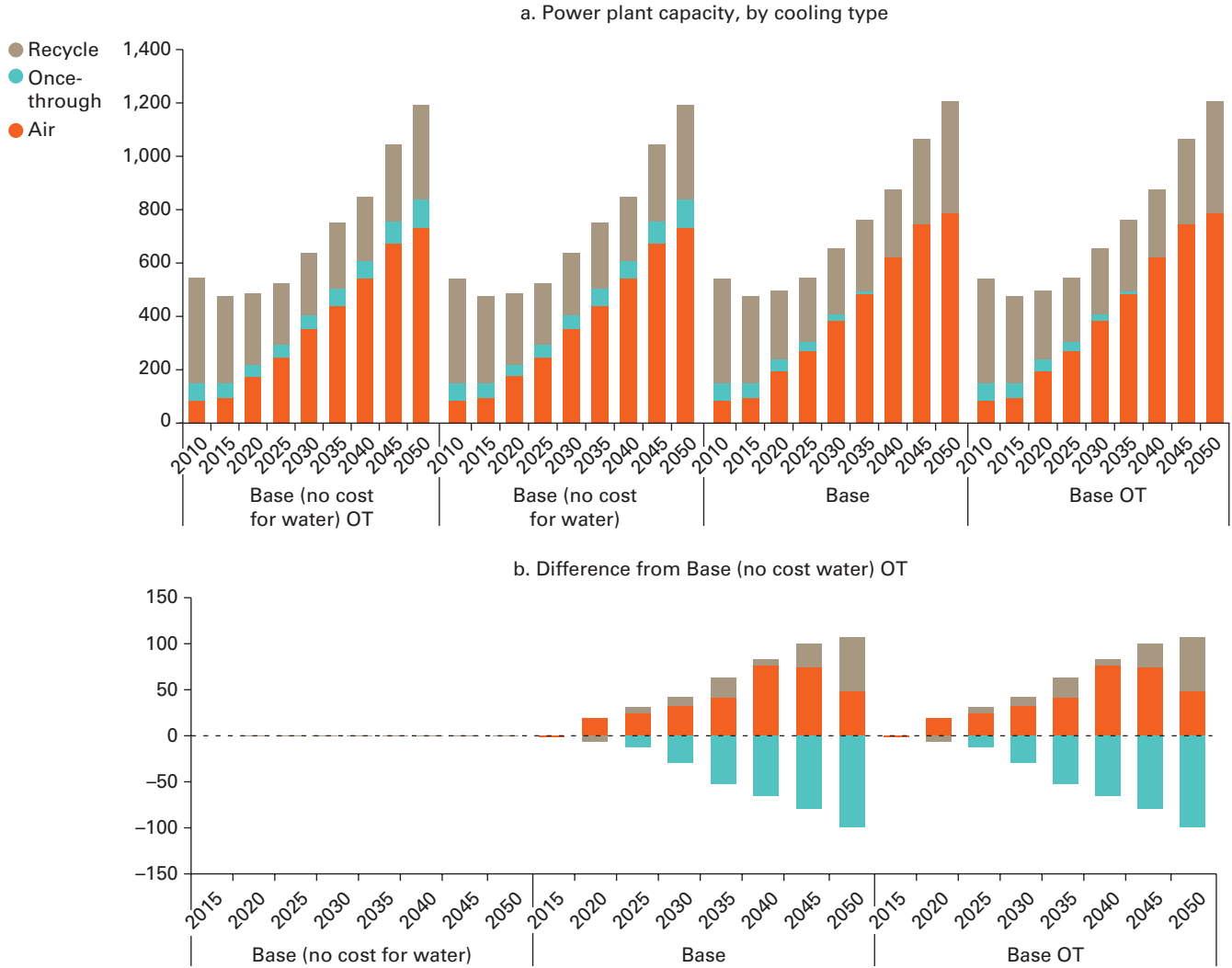
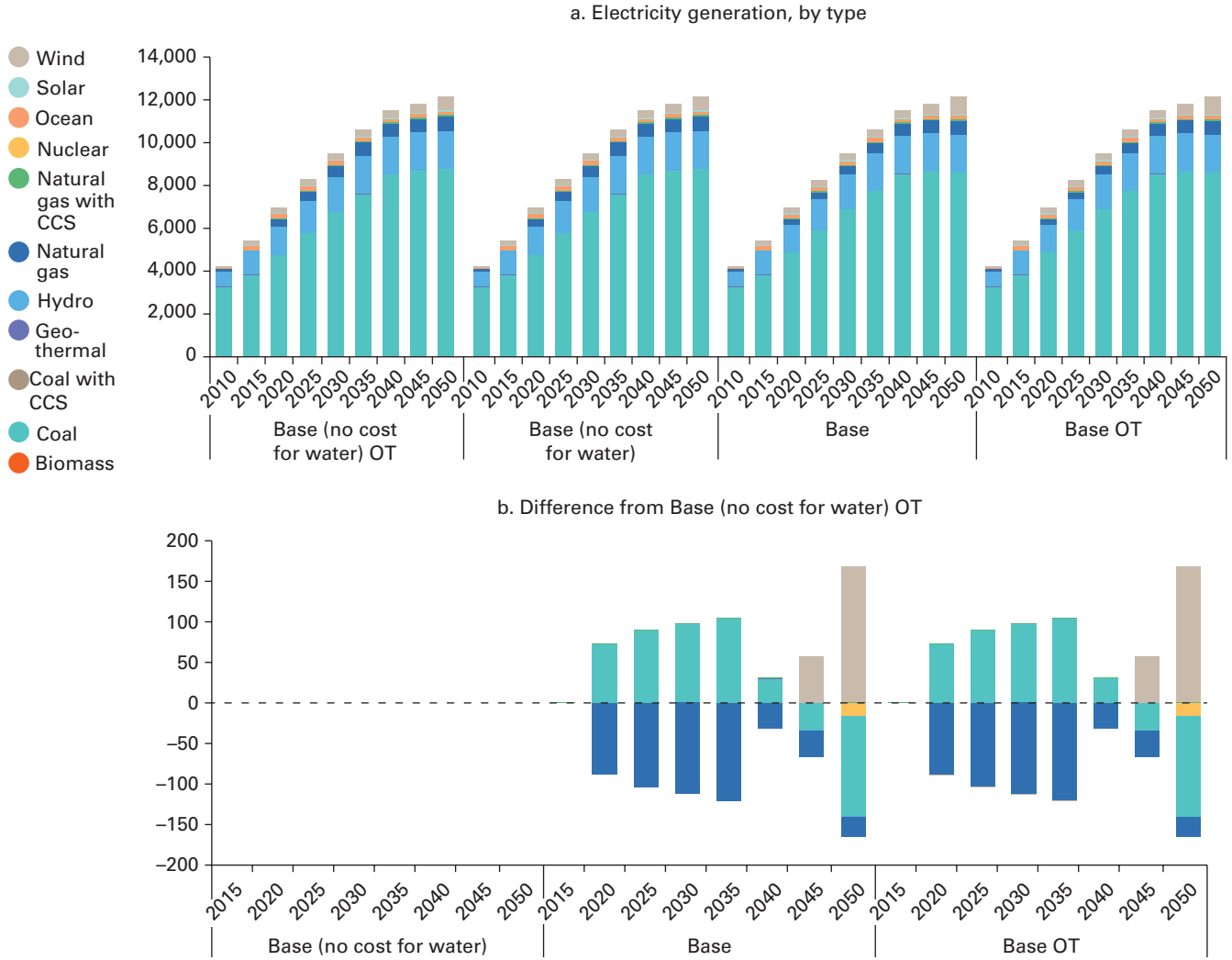

Figure 7.3

Electricity Generation, by Type: Effect of Water Supply Cost Cluster

Terawatt-hours



Note: CCS = carbon capture and storage; CHP = combined heat and power; CSP = concentrating solar power; OT = Once-Through; PV = photovoltaic.

Figure 7.4

Water Withdrawal by the Energy Sector, by Type and by Region: Effect of Water Supply Cost Cluster

Billion cubic meters

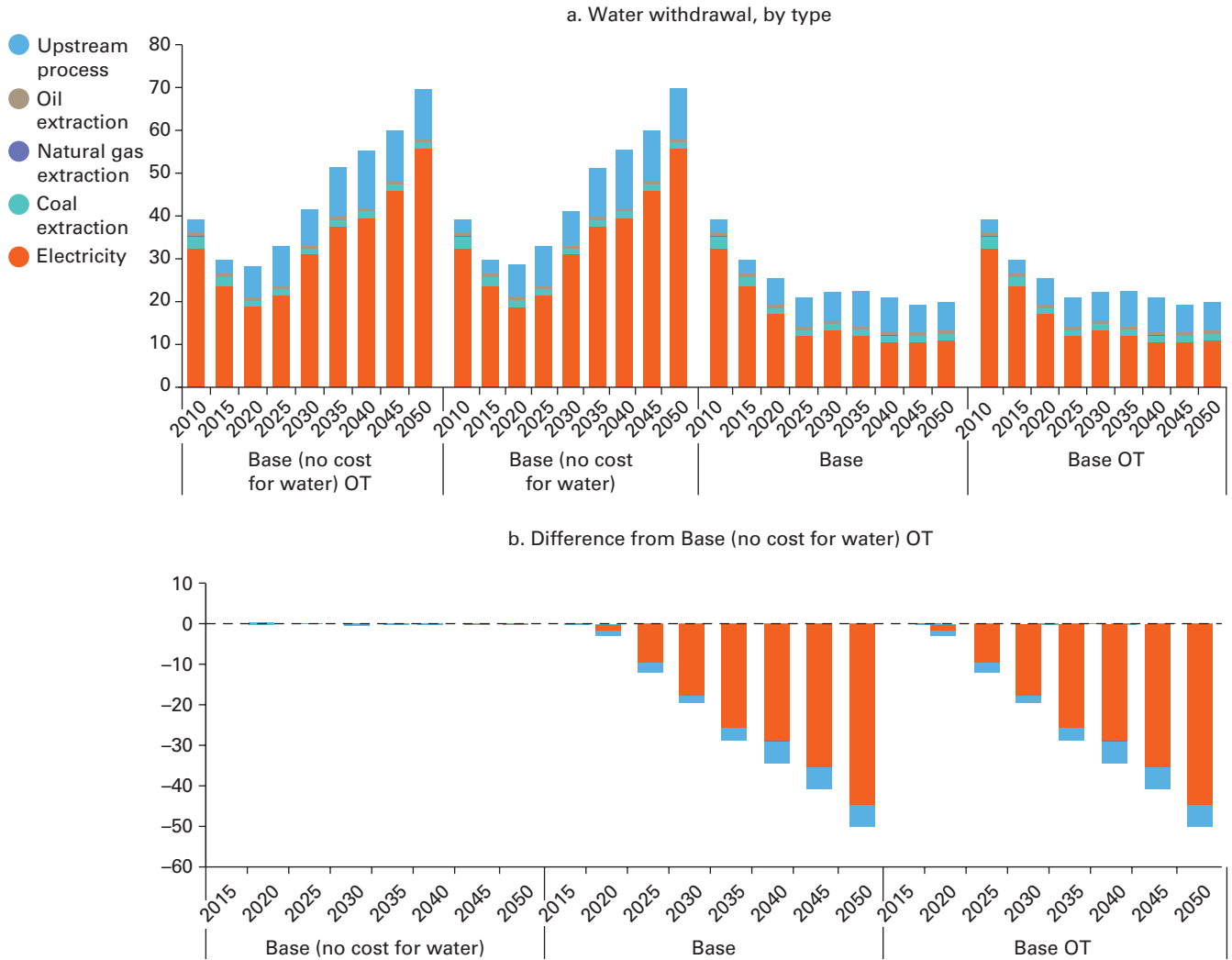

(continued)

Figure 7.4

Water Withdrawal by the Energy Sector, by Type and by Region: Effect of Water Supply Cost Cluster (continued)
Billion cubic meters

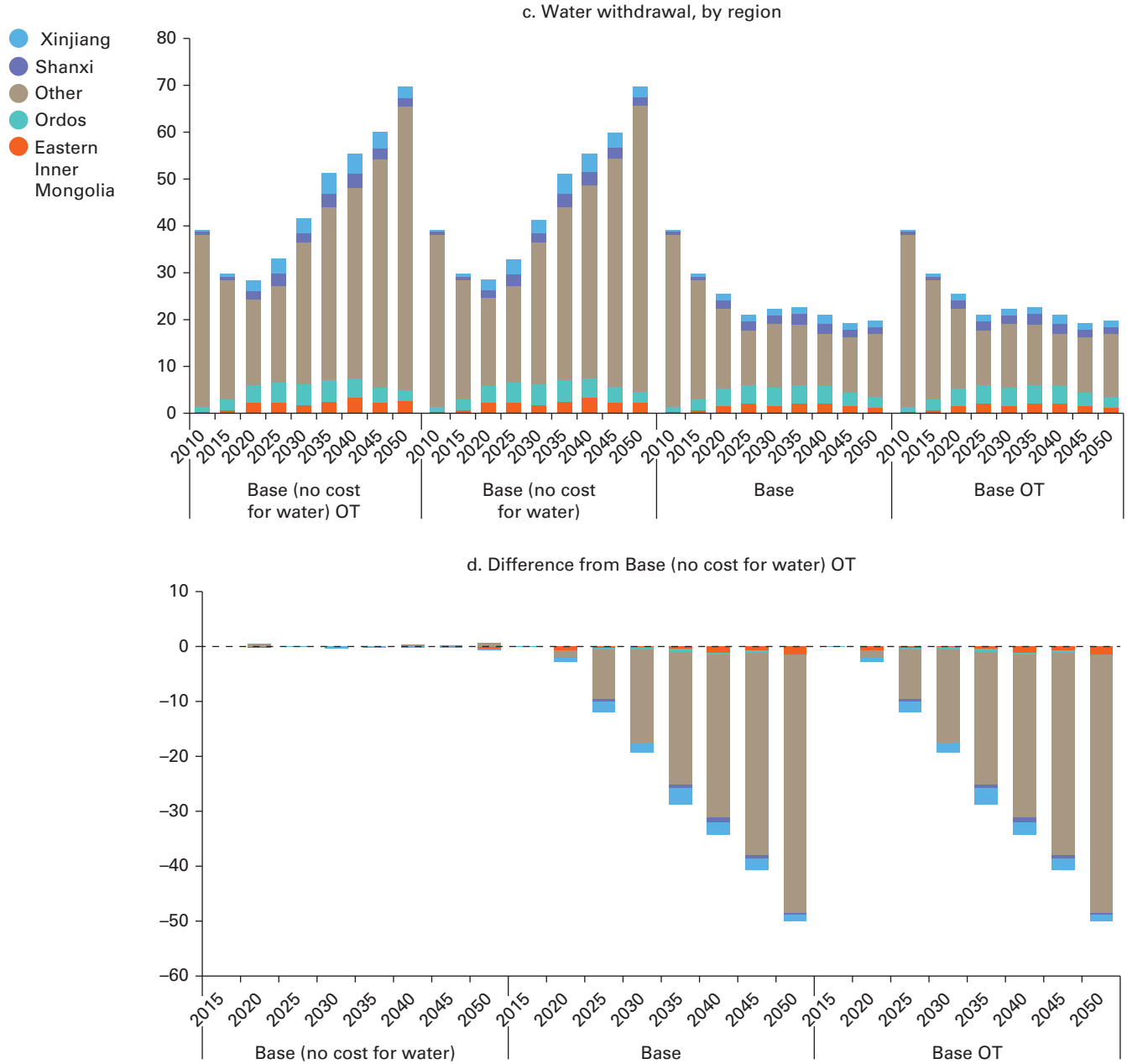

Effect of Water Cost and Carbon Dioxide Policy

The Reference scenario adds several policies to cut CO₂ emissions to the Base scenario, including a limit on CO₂ emissions and implementation of energy efficiency measures. Figure 7.5 shows that including the cost of water supply increases the total energy system cost by 0.31 percent in the Base scenario and 0.30 percent in the Reference scenario. Also, in both cases, the CO₂ policy (Reference) increases the total system cost by about 2.8 percent.

Figure 7.6 shows that the CO₂ policy (Reference) decreases both water withdrawal and water consumption by the energy sector and causes changes in electricity generation and upstream processes (Reference vs. Base scenarios). When the water supply cost is added in the Reference scenario, total water consumption by the energy sector decreases, mainly due to the decrease of upstream processes such as coal to liquids and coal to gas. The CO₂ policies have also a significant effect on technology choices. Figure 7.7 shows that water withdrawals for electricity generation shifts from traditional coal-fired power to Non-fossil technologies, mainly concentrated solar power (CSP) and coal with carbon capture and storage (CCS). Moreover, water withdrawals also decrease, due to the shift from coal to Non-fossil technologies that require no water such as wind, solar PV and nuclear (the model assumes that nuclear will be located along the coast using sea water for cooling) in response to the CO₂ constraint.

Figure 7.5

Total Cumulative System Cost (2010-2050): Water Cost and CO₂ Policy

Million dollars

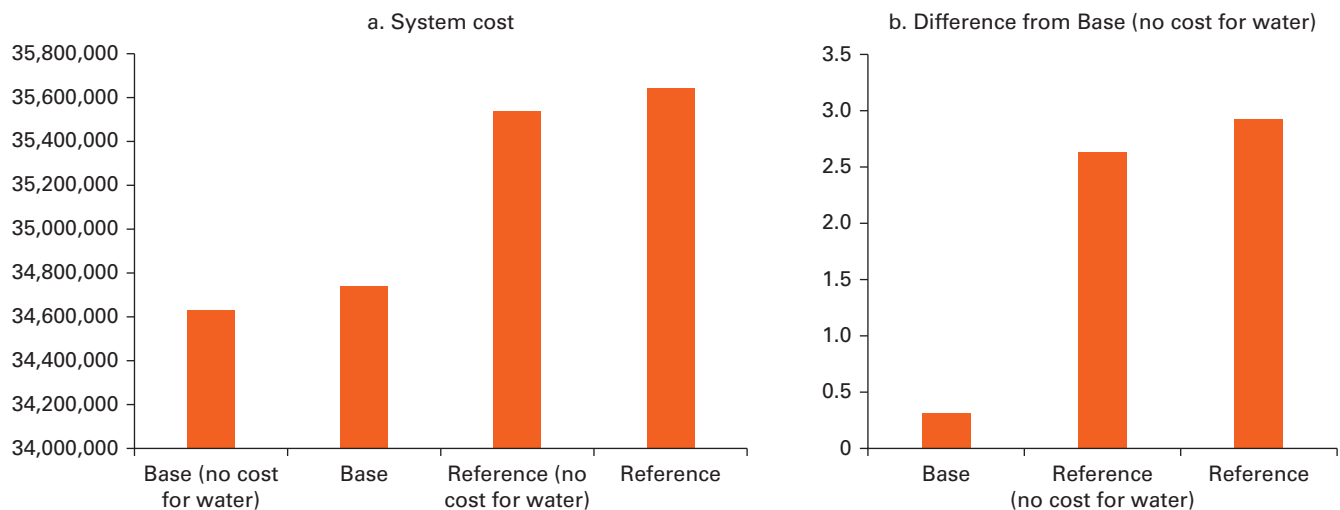

Figure 7.6

**Energy Sector Water Withdrawals and Consumption, by Type:
Water Cost and CO₂ Policy**

Billion cubic meters

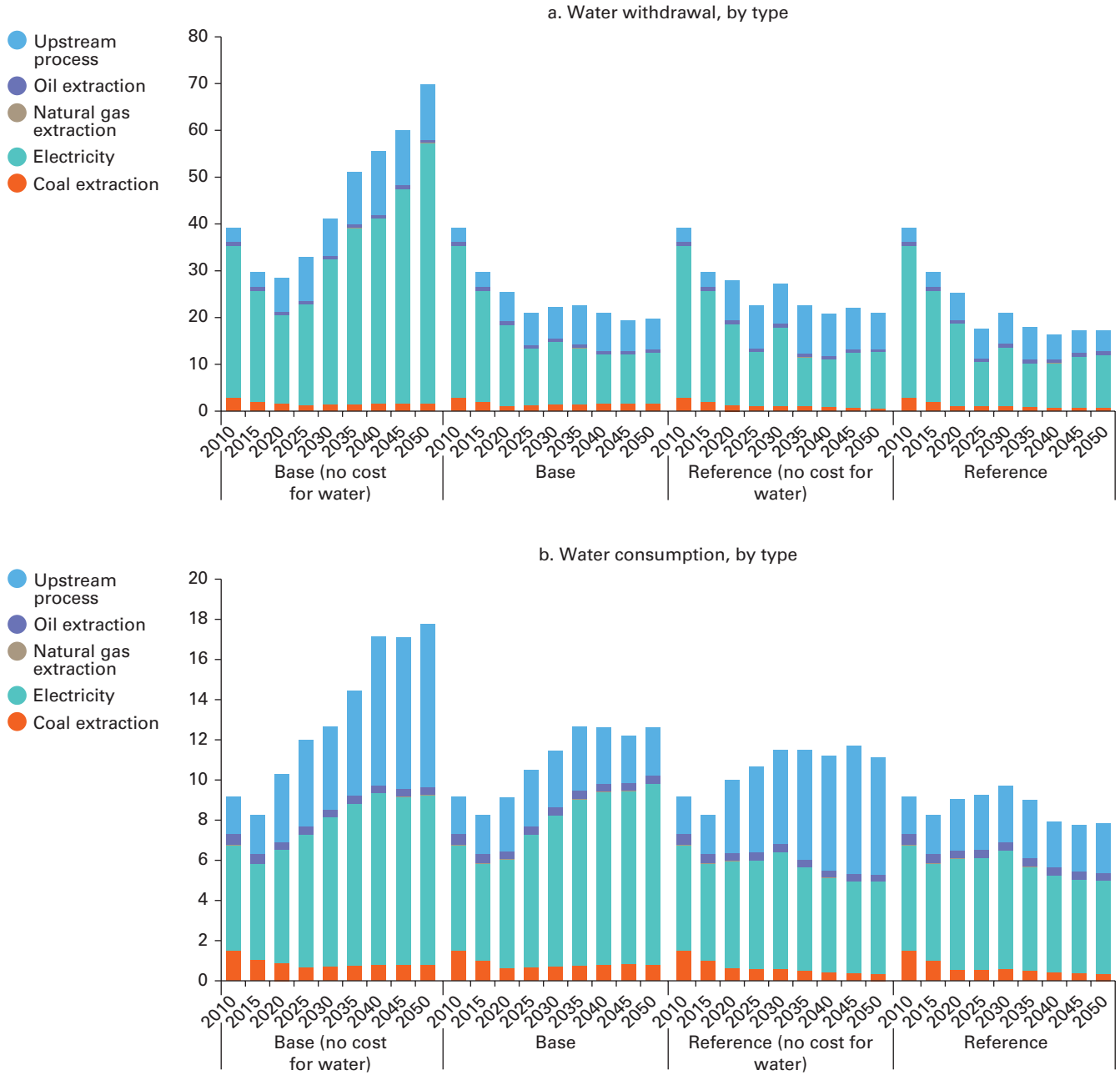
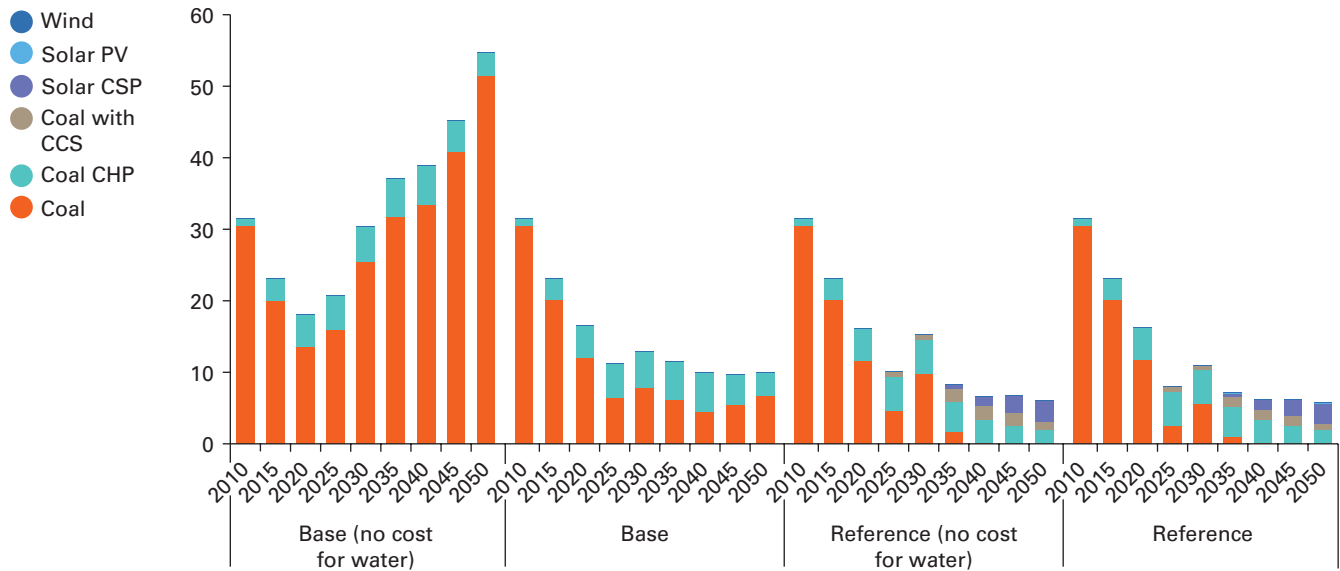

Figure 7.7

Power Sector Water Withdrawals, by Plant Type: Water Cost and CO₂ Policy

Billion cubic meters



Note: CCS = carbon capture and storage; CHP = combined heat and power; CSP = concentrating solar power; PV = photovoltaic.

Figure 7.8 shows that in the Base scenario, the Non-fossil energy share will continue to increase. In 2015, the ratio is as high as 48 percent. However, later it slows down slightly with a ratio constantly higher than 20 percent. In the Reference scenario under the emission constraint, the share of Non-fossil energy power plants in the newly built power plant is always higher than 45 percent and can achieve 80 percent in 2050.

Figure 7.9 shows that the coal power plant cooling types change under the Reference scenario, phasing out once-through and recirculating cooling and being replaced by air-cooling. In addition, the air cooled coal capacity is also reduced compared to the Base scenario because, as figure 7.10 shows, overall electricity generation capacity in the Reference scenario shifts substantially from coal to nuclear, solar, and wind.

Figure 7.11 shows that the Reference scenario has significantly more clean electricity generation than the base Scenario by 2050. Nuclear, solar, and wind comprise 32 percent, 16.1 percent, 15.0 percent of total generation, respectively, in the Reference scenario but only 1.2 percent, 0.5 percent, 6.5 percent, respectively, in the Base scenario. This is primarily because of the CO₂ emissions limit.

Figure 7.8

Share of Non-Fossil Energy in the Newly Built Power Plant Capacity

Percent

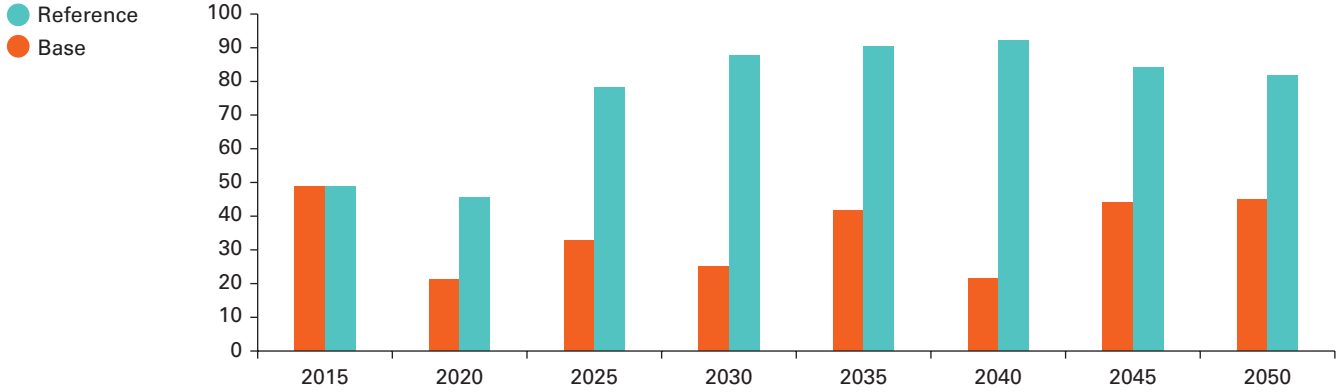

Figure 7.9

Coal Power Plant Capacity, by Cooling Type: Water Cost and CO₂ Policy

Gigawatts

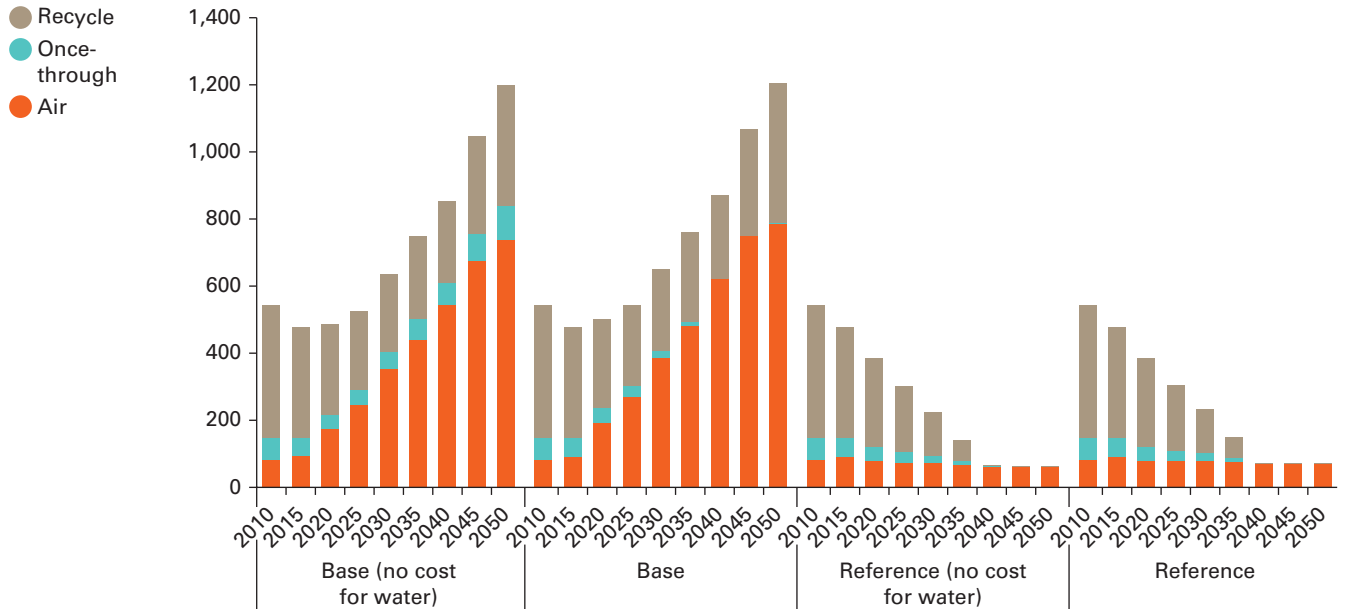
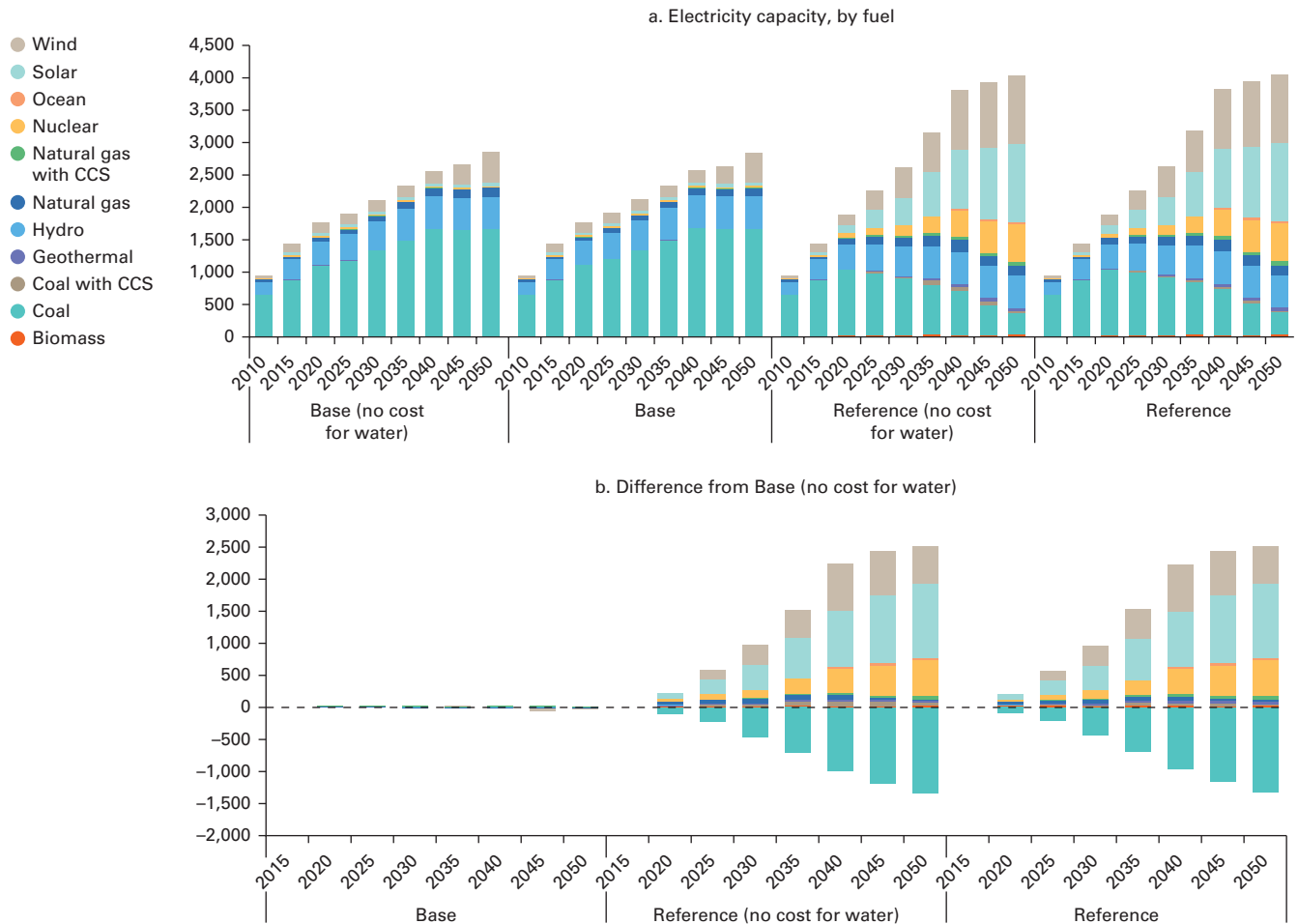

Figure 7.10

**Power Plant capacity and Change: Water Cost and CO₂ Policy
Gigawatts**



Note: CO₂ = carbon dioxide; CCS = carbon capture and storage.

Figure 7.12 shows very rapid increases in new wind, solar, and nuclear power plants starting in 2025 along with the retirement of coal plants in the Reference Scenario. These build rates are consistent with the government's current plan and with the impressive expansion plans recently implemented for these power plant types. Because of the intermittent nature of wind and solar plants (and thereby lower use factors), total installed capacity increases by 400 GW in 2050 in the Reference scenario.

Figure 7.13 shows that in the Reference scenario generating capacity shifts from Shanxi (a coal-rich region) to all the other regions because of the reduction in new

Figure 7.11

Electricity Generation Structure of Base and Reference: Water Cost and CO₂ Policy, 2050

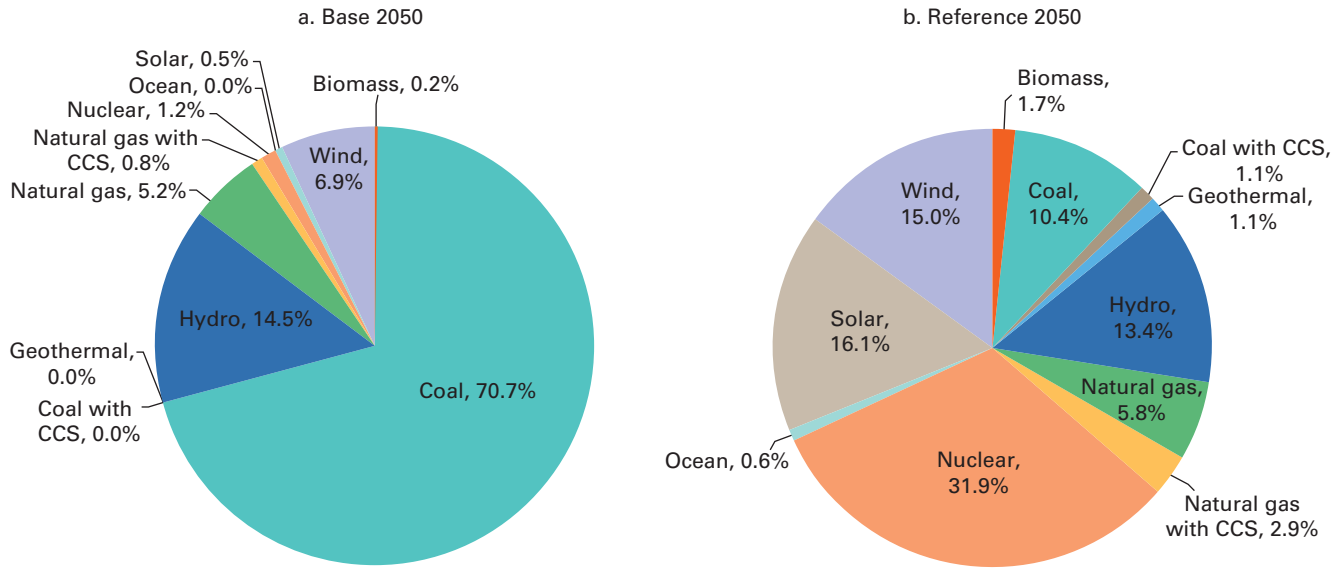

Note: CO₂ = carbon dioxide; CCS = carbon capture and storage.

coal-fired generation. Figure 7.14 shows that under the Reference scenario (CO₂ policy), regional net electricity trade decreases from the Energy Bases, particularly Shanxi and Eastern Inner Mongolia, whereas trade from Xinjiang increases. The overall trade from the Energy Bases declines under this policy as more nuclear plants are built in the Other region.

Figure 7.15 shows that the Reference scenario increases the society’s reliance on electricity in the later years because the increased use of electricity from nuclear and renewables pushes out direct use of fossil fuels in the demand sectors. Coal and oil are displaced from the final energy mix and are partially replaced by increased natural gas use (domestic and imports) and energy efficiency improvements on the demand side. The CO₂ constraint decreases final energy use by around 5 percent, most of which comes from the transportation and buildings sectors (see figure 7.16).

Figure 7.17 shows that the Reference scenario reduces CO₂ emissions primarily from the power sector, with a contribution from demand devices through fuel switching and efficiency improvements, as just noted, as well as reduced coal mining (material processes). Figure 7.18 shows that, in 2050, the Reference scenario will reduce emissions mostly from power plants.

Figure 7.12

Electric Power Plant New Builds and Change, by Type: Water Cost and CO₂ Policy

Gigawatts

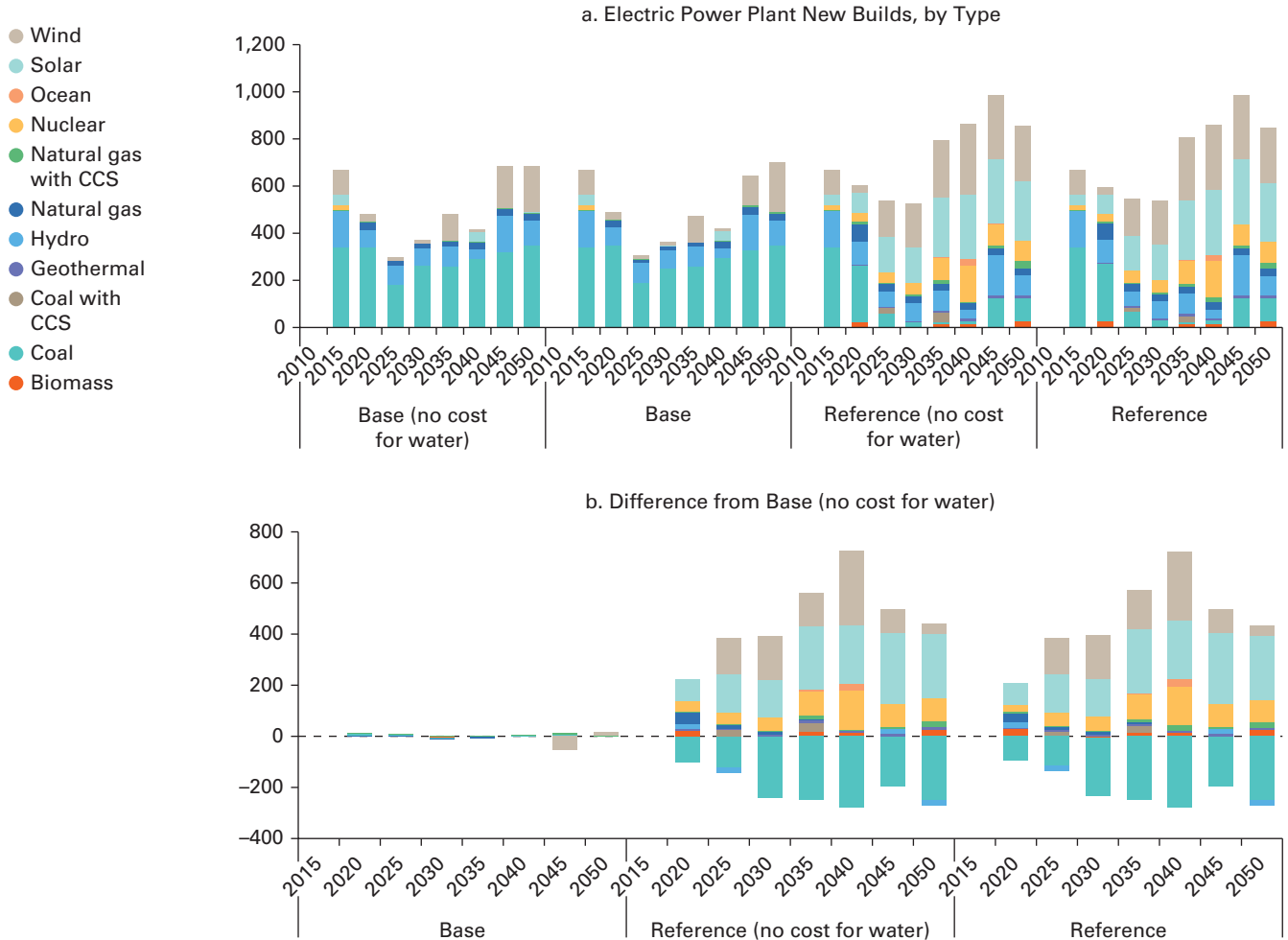

Note: CO₂ = carbon dioxide; CCS = carbon capture and storage.

Figure 7.13

Generating Capacity and Difference, by Region: Water Cost and CO₂ Policy
Gigawatts

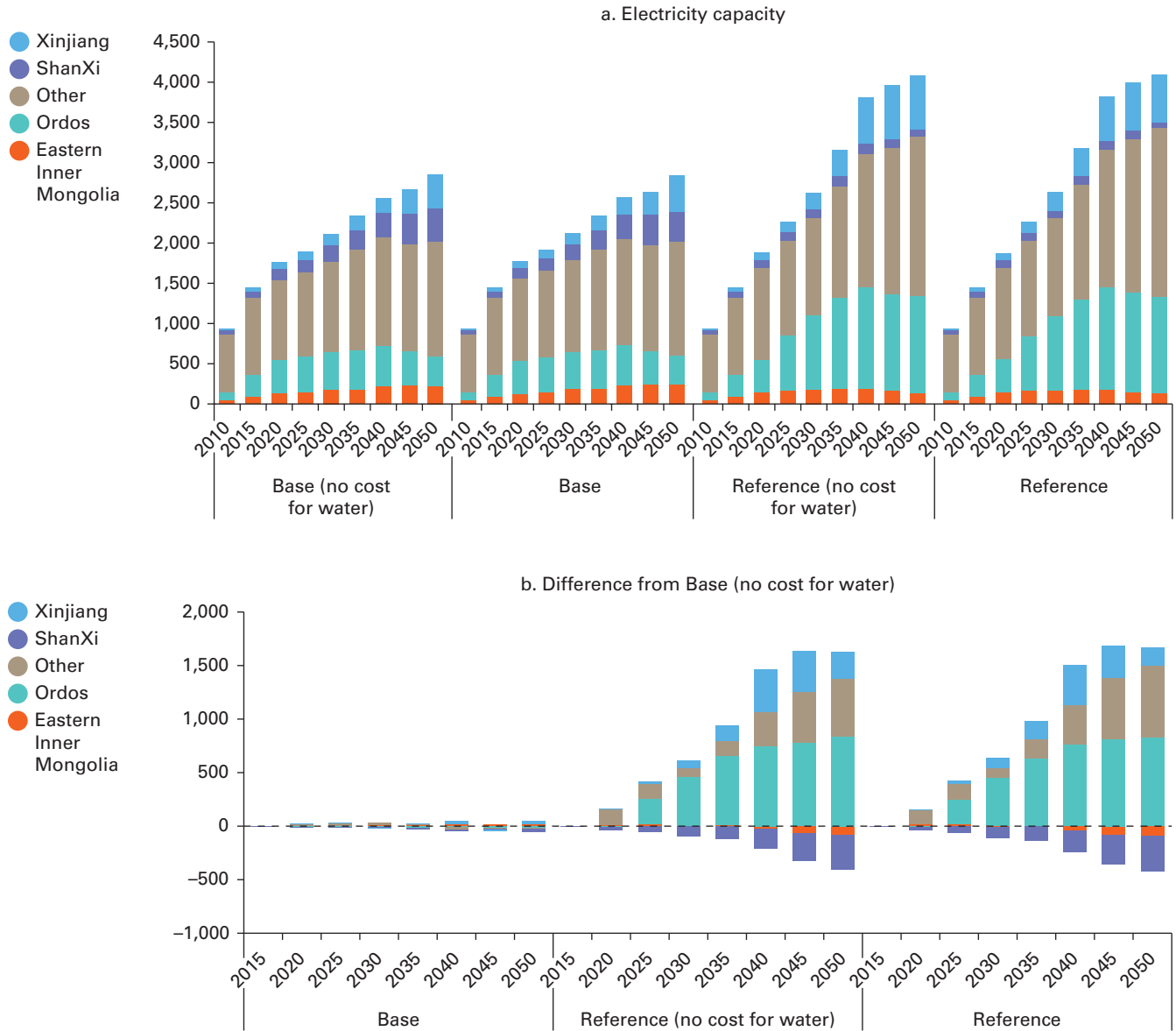

Note: CO₂ = carbon dioxide.

Figure 7.14

Regional Electricity Trade: Water Cost and CO₂ Policy
Petajoules

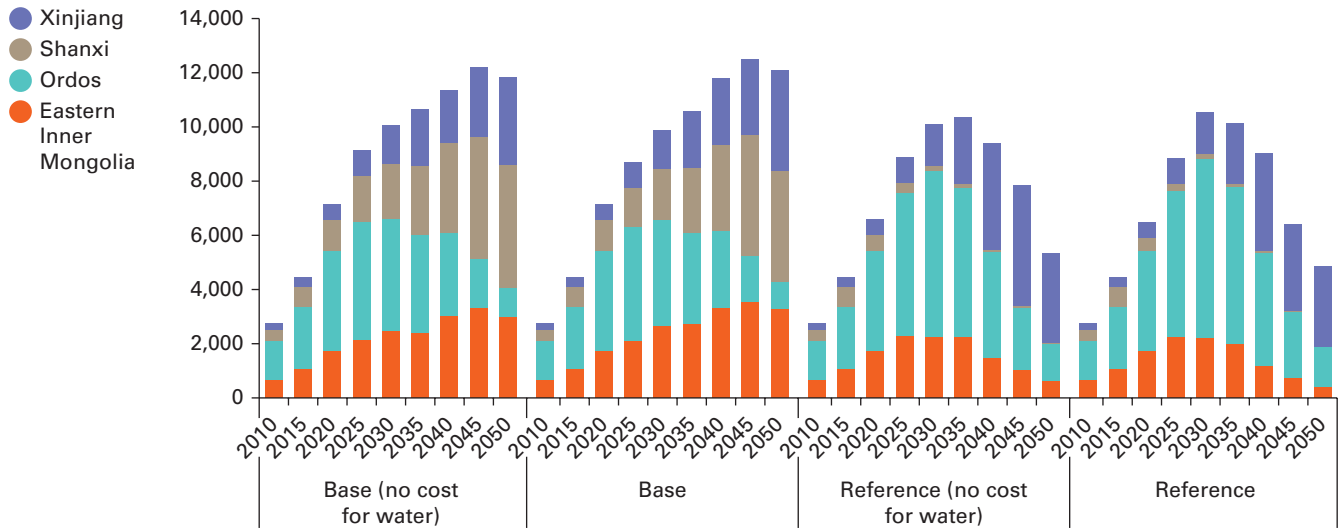

Note: CO₂ = carbon dioxide.

Figure 7.15

Final Energy and Change, by Fuel: Water Cost and CO₂ Policy
Petajoules

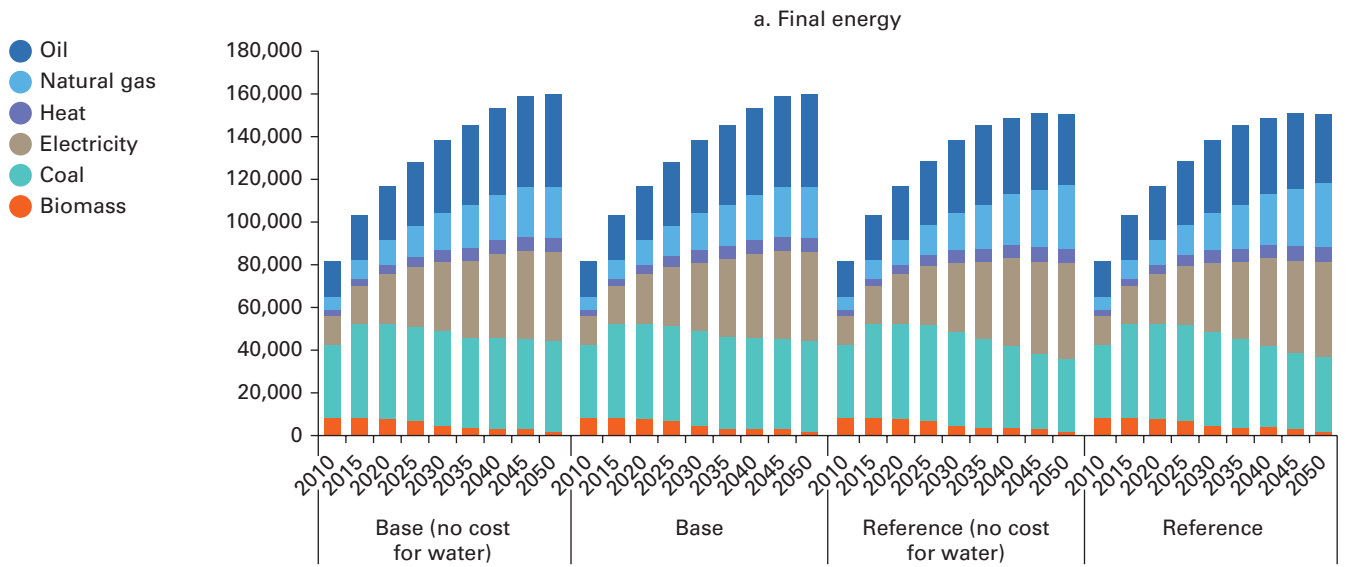

(continued)

Figure 7.15

Final Energy and Change, by Fuel: Water Cost and CO₂ Policy
(continued)

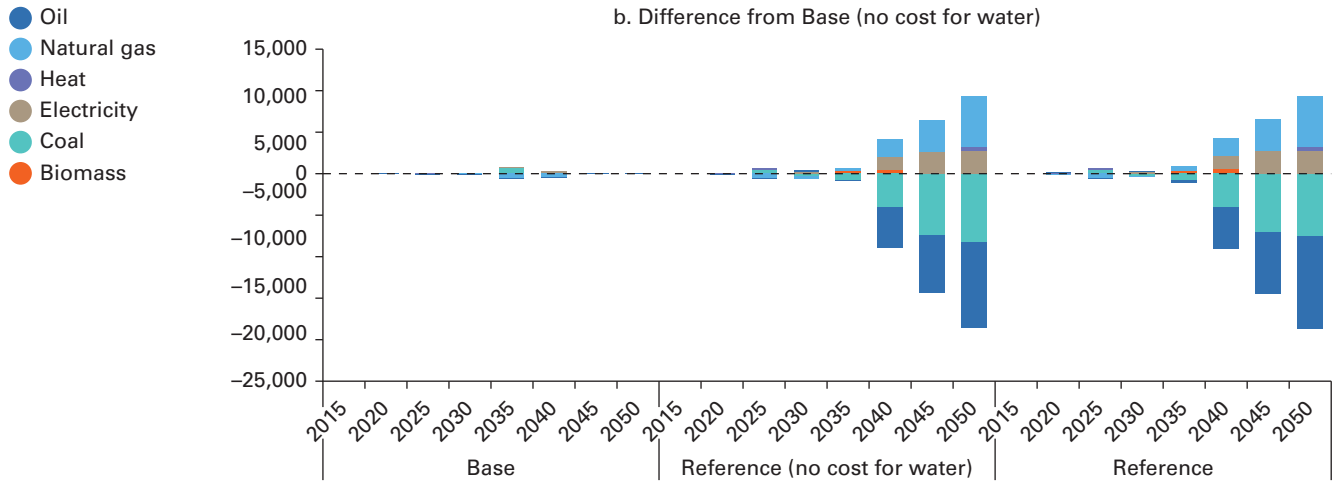

Note: CO₂ = carbon dioxide.

Figure 7.16

Final Energy and Change, by Sector: Water Cost and CO₂ Policy
Petajoules

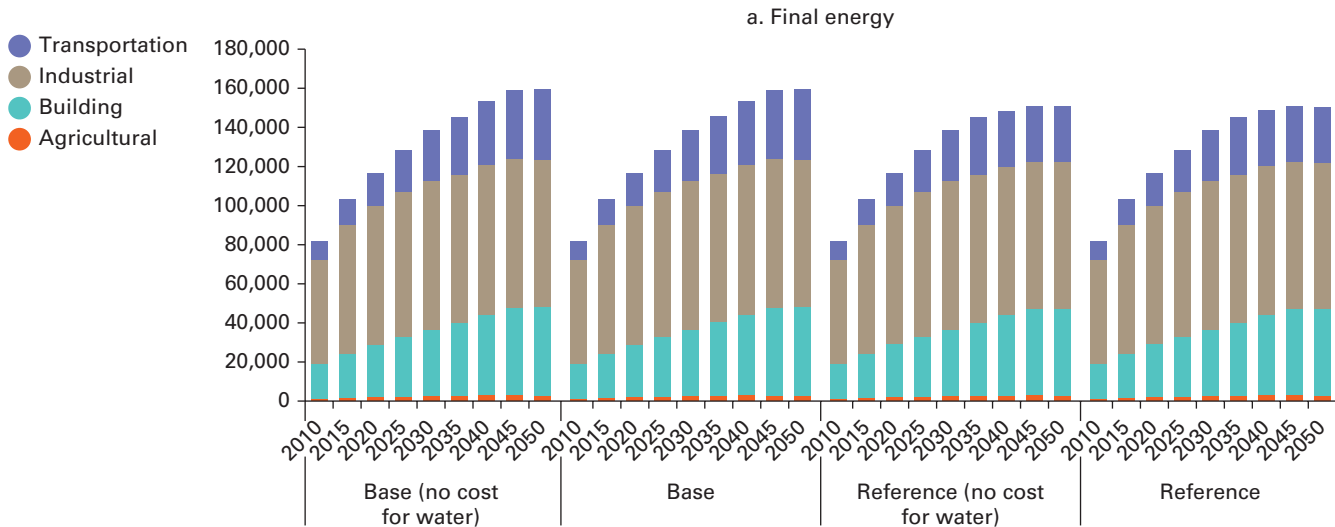

(continued)

Figure 7.16

Final Energy and Change, by Sector: Water Cost and CO₂ Policy
(continued)

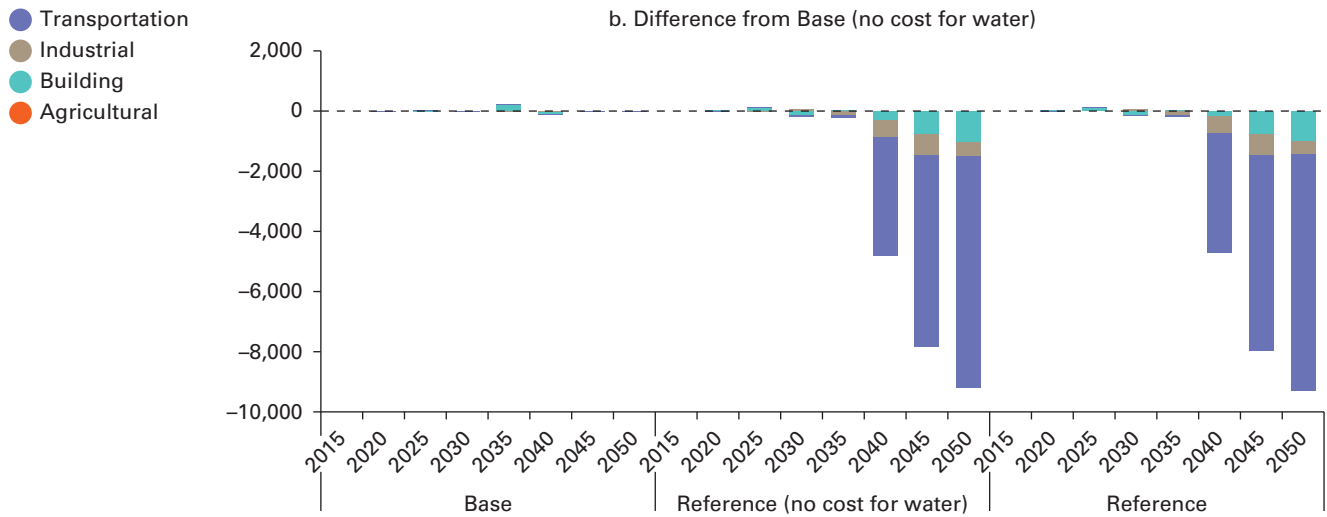

Note: CO₂ = carbon dioxide.

Figure 7.17

CO₂ Emissions and Change: Water Cost and CO₂ Policy
Million metric tons

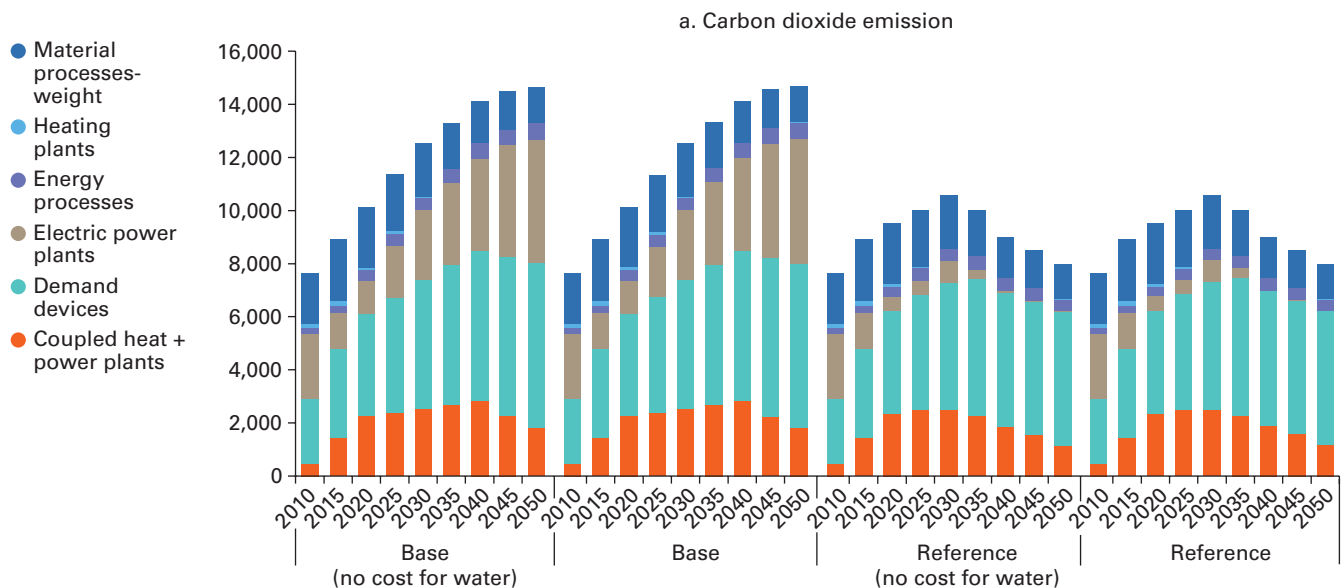

(continued)

Figure 7.17

CO₂ Emissions and Change: Water Cost and CO₂ Policy (continued)

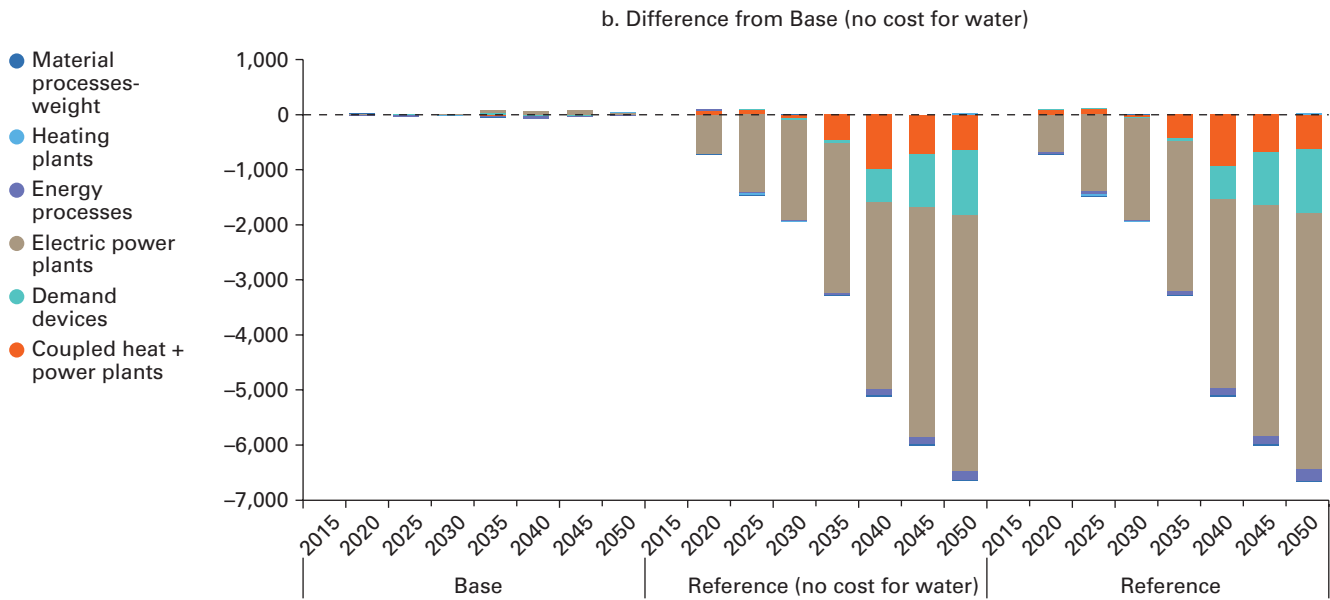

Figure 7.18

CO₂ Emissions: Water Cost and CO₂ Policy, 2050

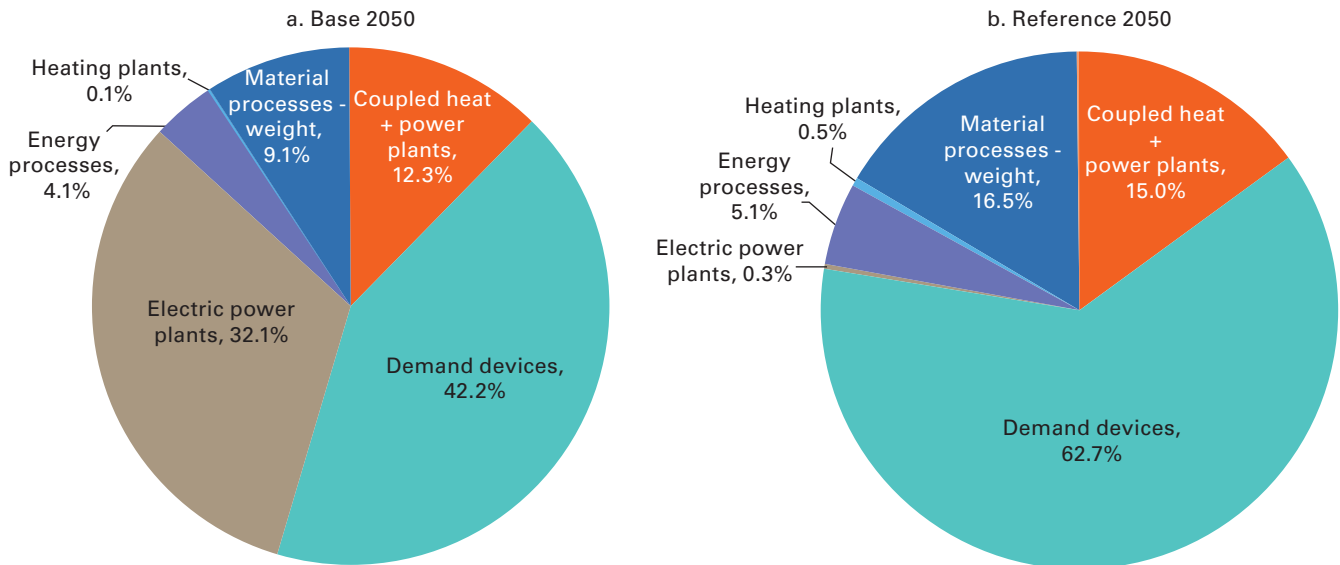
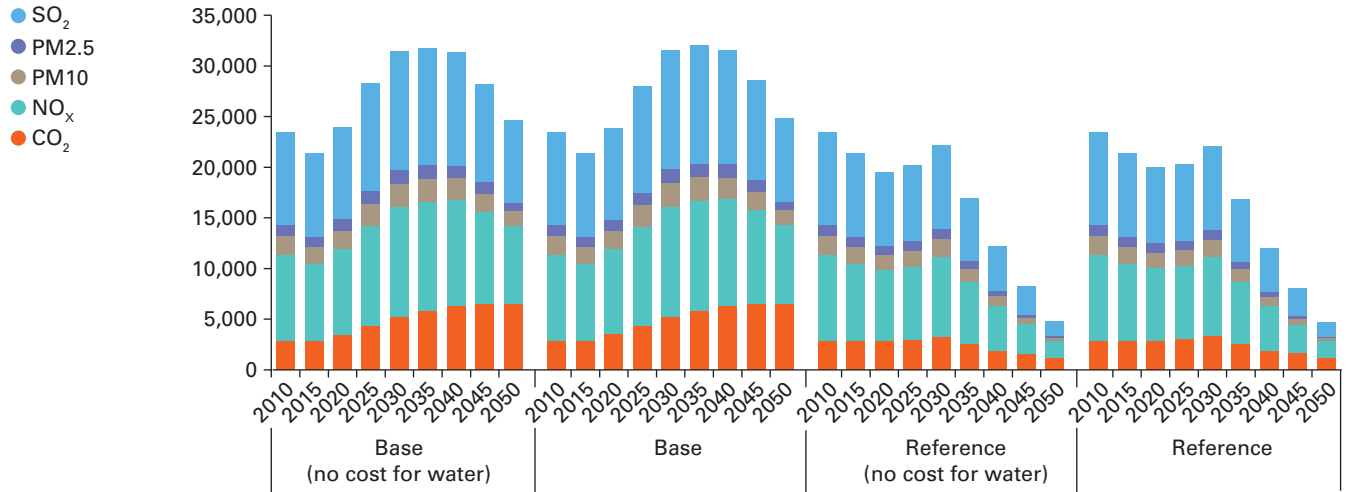

Figure 7.19

Power Sector Emissions, by Pollutant Type: Water Cost and CO₂ Policy

Million metric tons



Note: CO₂ = carbon dioxide; NO_x = nitrogen oxides; PM10 = particulate matter 10; PM2.5 = particulate matter 2.5; SO₂ = sulphur dioxide.

Figure 7.19 shows that co-benefits from the CO₂ policy (Reference scenario) include substantive reduction in local air pollutants. Besides CO₂ emissions decreasing nearly 50 percent, the policy also causes reductions of 37 percent of nitrogen oxides (NO_x), 36 percent of particulate matter (PM) 10, 36 percent of PM 2.5 and 39 percent of sulphur dioxide (SO₂) occur from 2010 to 2050.

Coal Reduction Policies

In addition to the CO₂ limit, which is incorporated into the Reference scenario, three additional government policies were examined: the Coal Peak policy (limit coal production starting in 2020), the Non-fossil plan (raise the share of Non-fossil energy by 2030), and the coal chemicals policy (increased coal-to-liquid production starting in 2020). The Coal Peak policy is the most expensive, at more than 0.7 percent increase over the Reference scenario in total system cost or \$250 billion over the 40-year planning

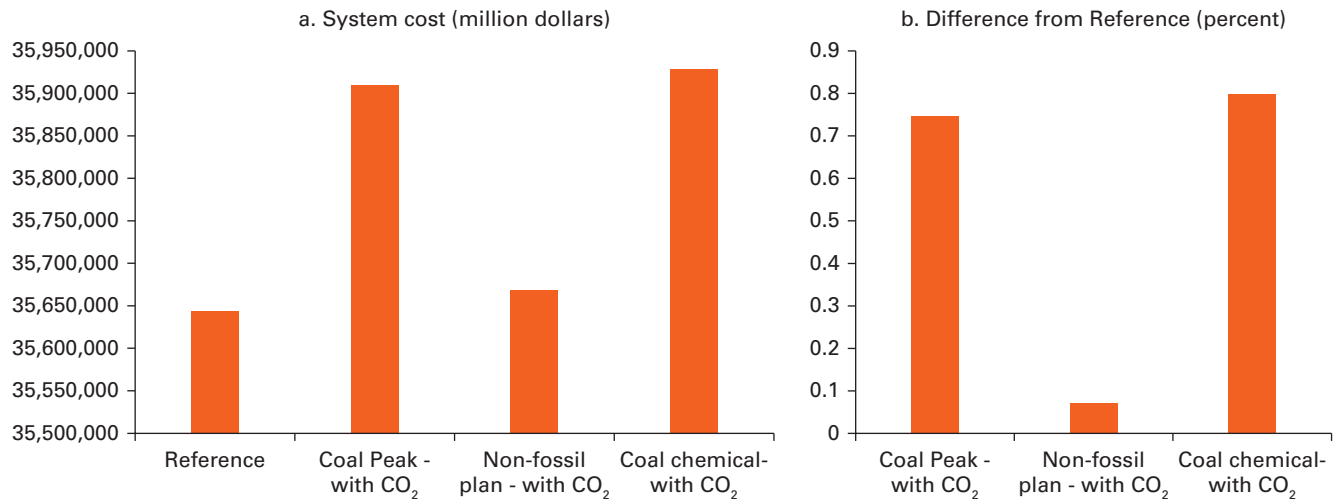
Figure 7.20**Total Cumulative System Cost (2010-2050) and Difference of the Core Government Policies**

horizon. The Reference scenario (CO₂ policy) is 2.4 percent above the Base scenario with water supply costs (see the “Effect of Water Cost and Carbon Dioxide Policy” section), indicating that the combined effect of the two policies is slightly more than an increase of 3 percent in total system cost. Figure 7.20 shows the change of the total system cost compared with the Reference scenario.

Figure 7.21 shows the actual effect of the individual policies (without the effect of the CO₂ constraint but including the cost of water supply), where the Coal Peak policy is clearly the most restrictive and thereby the costliest of the policies, increasing the system cost by \$1.2 trillion over the Base scenario.

Figure 7.22 shows that, compared with the Reference case, the Coal Peak policy scenario reduces overall water use, but the big decrease in water use for electricity generation is offset partially by the increases in water use for upstream processes related to increased natural gas production. The Non-fossil plan scenario does not change water use much compared with the Reference case, which already chooses many of the Non-fossil options that appear in the Non-fossil plan scenario. However, the Coal chemical policy scenario increases water use for the coal-to-liquid and coal-to-gas processes that this scenario promotes.

Figure 7.23 shows that the Coal Peak policy scenario promotes shifting electricity generation from coal to a mix of gas, nuclear, and renewables, more quickly and strongly than the CO₂ policy (Reference) itself. However, the other policies have only

Figure 7.21

Total Cumulative System Cost (2010-2050) and Difference of Core Policies without CO₂

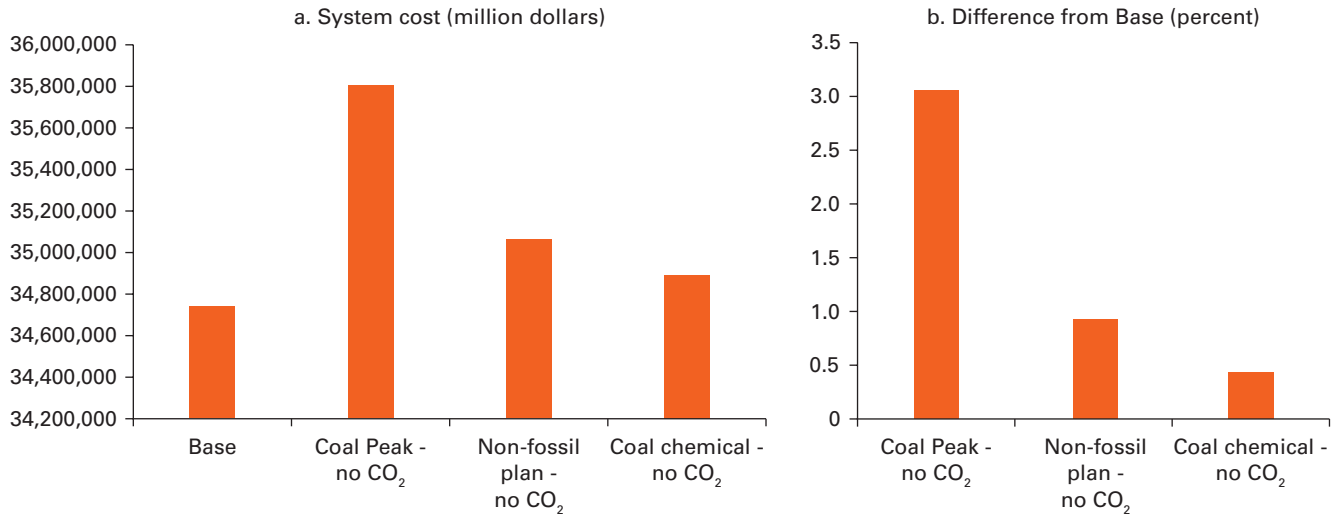

Note: CO₂ = carbon dioxide.

Figure 7.22

Energy Sector Water Withdrawal and Difference, by Type: Core Policies with CO₂

Billion cubic meters

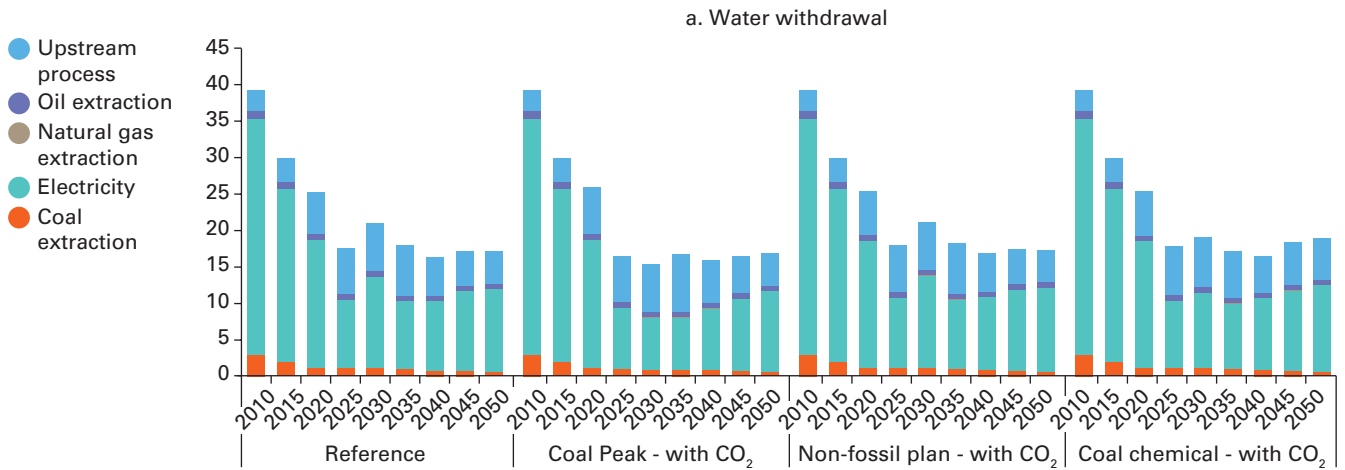

(continued)

Figure 7.22

Energy Sector Water Withdrawal and Difference, by Type: Core Policies with CO₂ (continued)

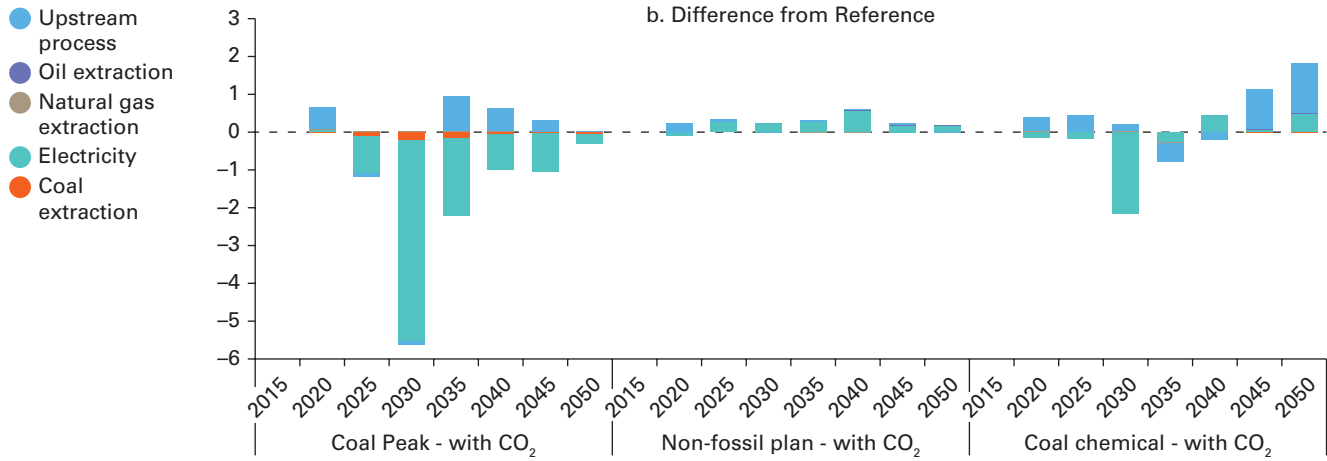

Note: CO₂ = carbon dioxide.

Figure 7.23

Electric Generation and Difference, by Plant Type: Core Policies with CO₂ Terawatt-hour

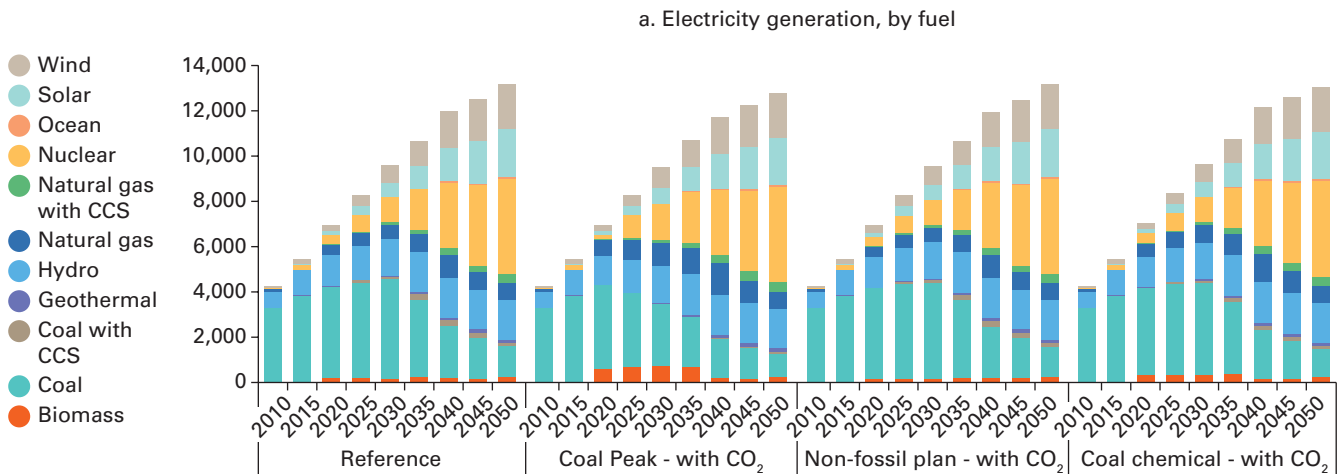

(continued)

Figure 7.23

Electric Generation and Difference, by Plant Type: Core Policies with CO₂ (continued)

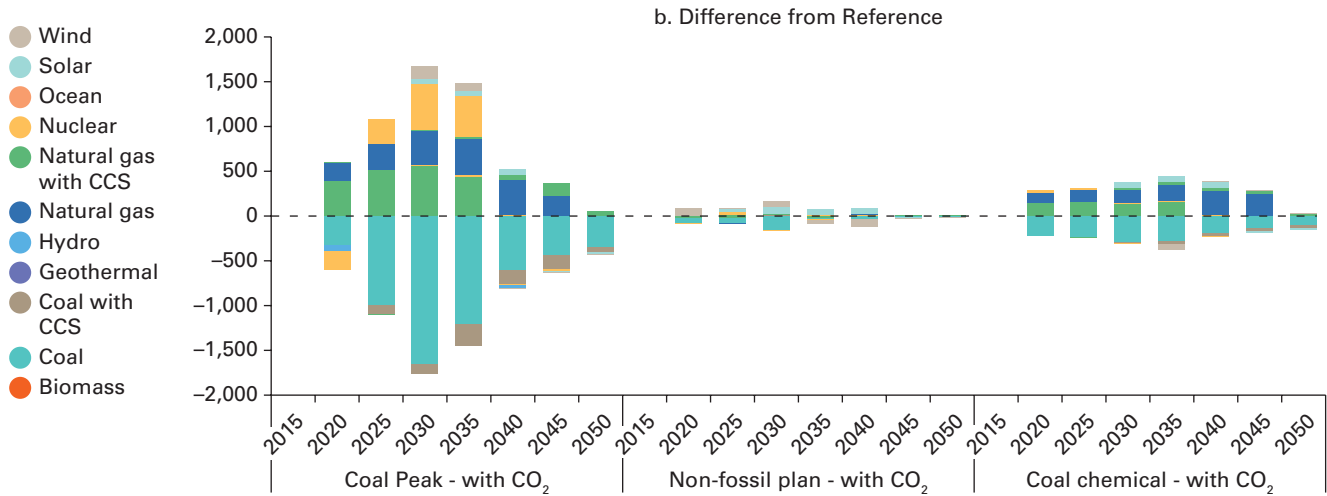

Note: CO₂ = carbon dioxide; CCS = carbon capture and storage.

minor effects on the generation mix because the CO₂ policy (Reference) already forces a shift away from coal.

Figure 7.24 shows that, compared with the Reference scenario, these policies tend to shift a small amount of generation (2–3 percent) into Ordos and away from the other Energy Bases. The Coal Peak policy also shows an initial increase in the Other region, whereas the Coal chemical policy shows a small increase in Xinjiang.

Figure 7.25 shows the effect of these policies on new power plant constructions and highlights the faster upgrade of nuclear and natural gas power plants in the Coal Peak scenario. The Non-fossil plan and the Coal chemical policy have a smaller effect on power plant builds given that most changes arising from these scenarios also occur in the Reference scenario, driven by the CO₂ constraint.

Figure 7.26 shows that the Coal Peak scenario leads to earlier reductions in CO₂ emissions, primarily from coal and coal CHP plant, but, by 2040, overall emission levels are the same as the Reference scenario, which raises the question of whether the timing for the Coal Peak is optimal. Note the tradeoff after 2040 where emissions from the demand sectors increase as a result of fuel switching away from electricity as the

Figure 7.24

Change in Electricity Generation, by Region: Core Policies with CO₂
Terawatt-hour

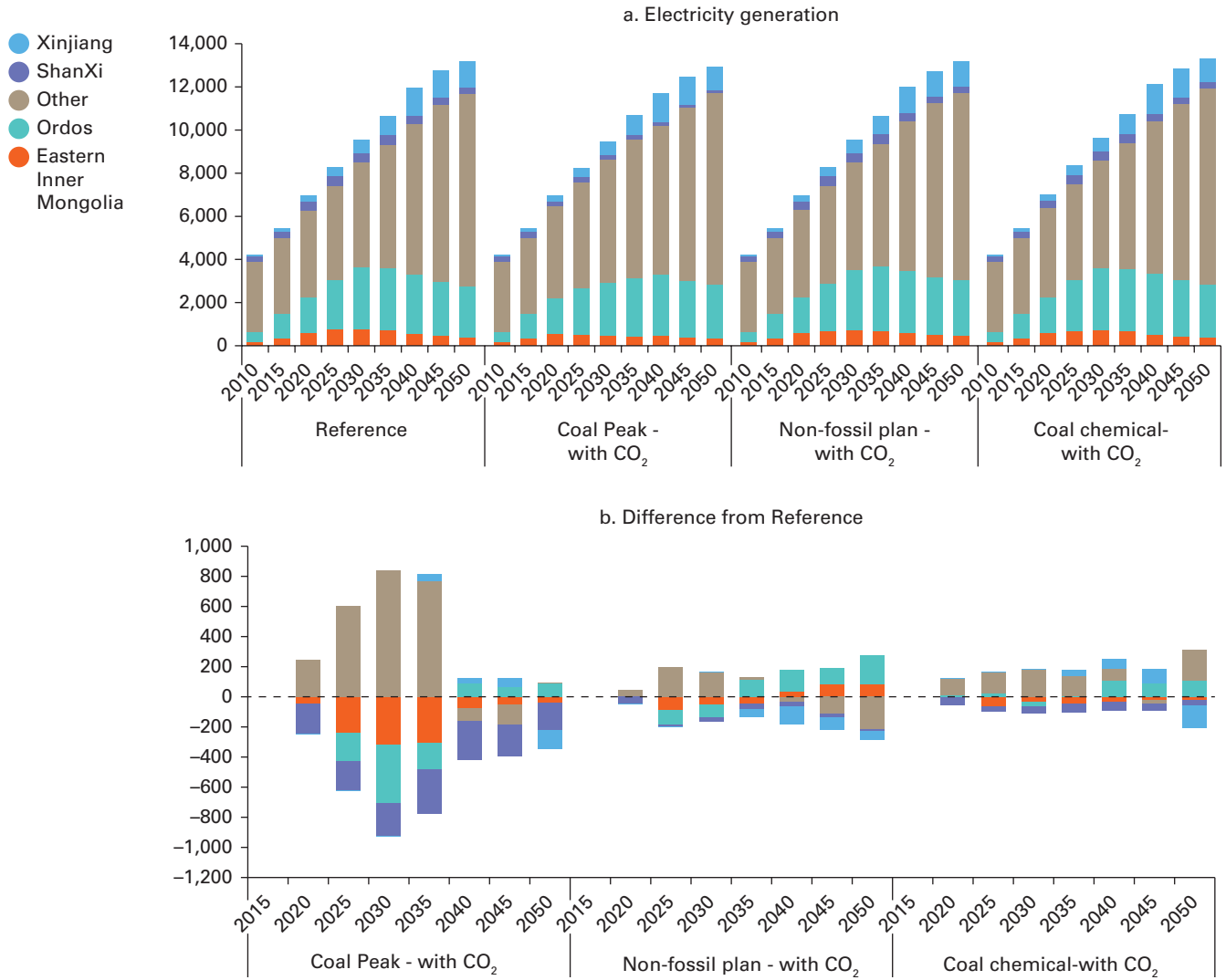

Note: CO₂ = carbon dioxide.

Figure 7.25

**New Power Plant Builds, by Type: Core Policies with CO₂
Gigawatts**



Note: CO₂ = carbon dioxide; CCS = carbon capture and storage.

Figure 7.26

CO₂ Emission and Difference in the Core Scenarios: Core Policies with CO₂
Million metric tons

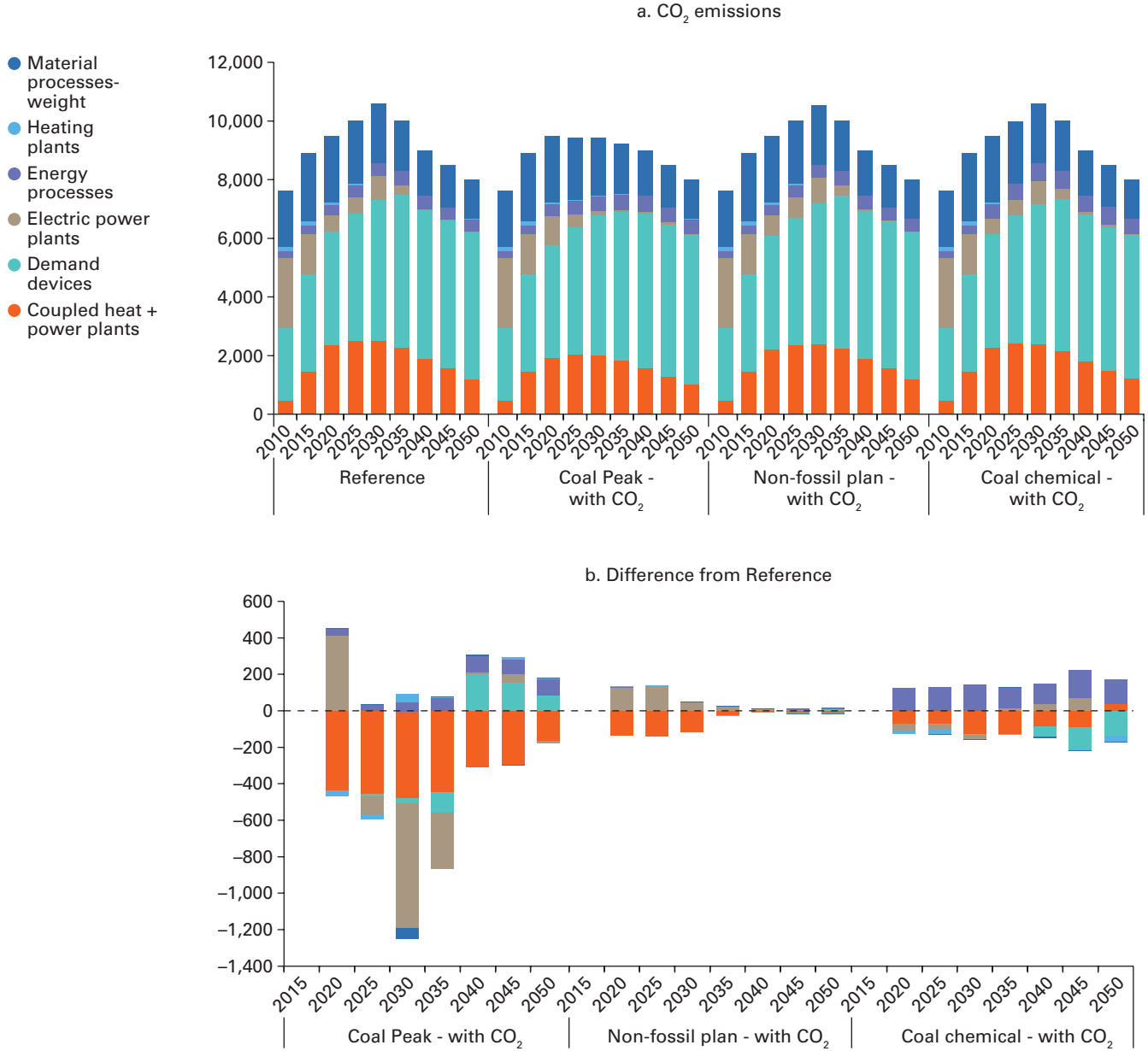

higher share of nuclear, natural gas, and renewables in the generation mix increases electricity prices in the later years.

As figure 7.27 shows, the Coal Peak policy results in a much steeper drop of CO₂ emissions starting in 2025, whereas in the Reference and other two policy scenarios CO₂ emission reductions are greatest after 2035 with a very steep trajectory. The Coal Peak scenario reduces CO₂ emissions from the power sector by about 1.7 billion tons in 2050 and results in a cumulative reduction of CO₂ emissions of more than 128 billion tons over what is achieved with only the CO₂ policy. These additional reductions are the result of the Coal Peak policy more strongly shifting electricity generation from coal to a mix of gas, nuclear, and renewables, and starting this transition a decade earlier. The same pattern of emission reductions can be seen for other air pollutants.

Figure 7.27 Power Sector Emissions, by Pollutant Type: Core Policies with CO₂
 Million metric tons

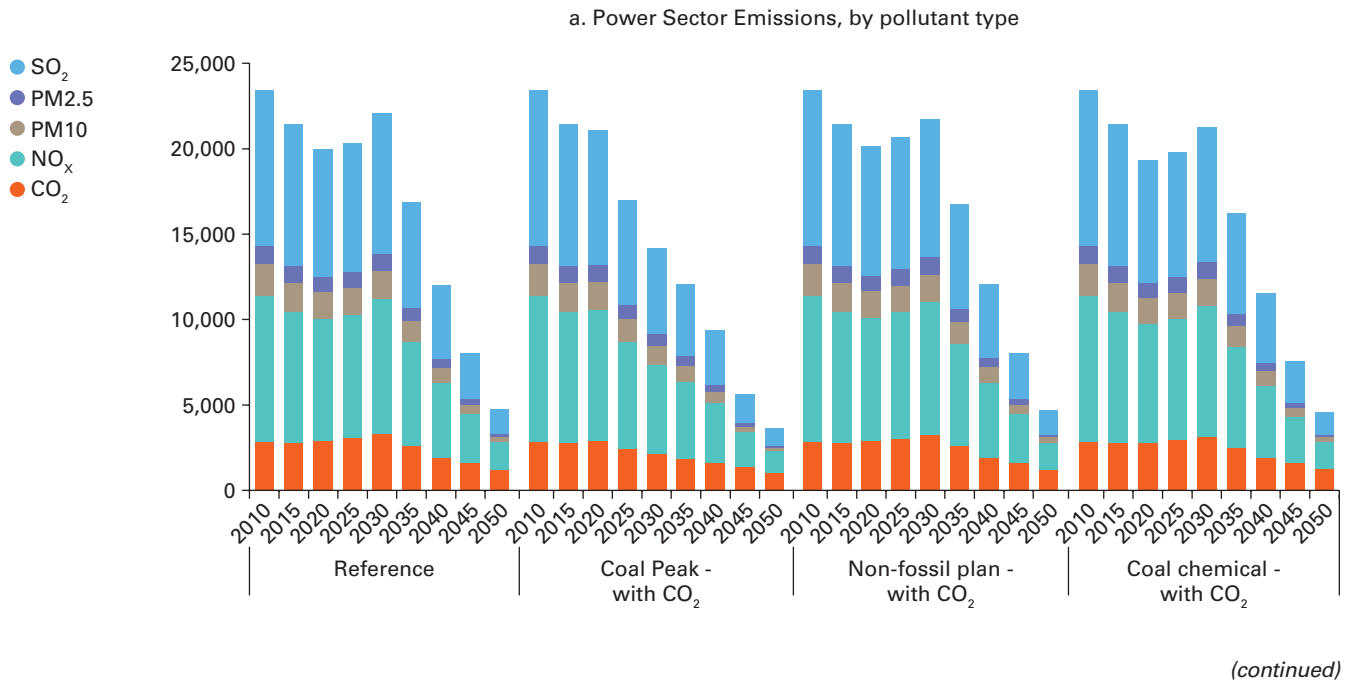
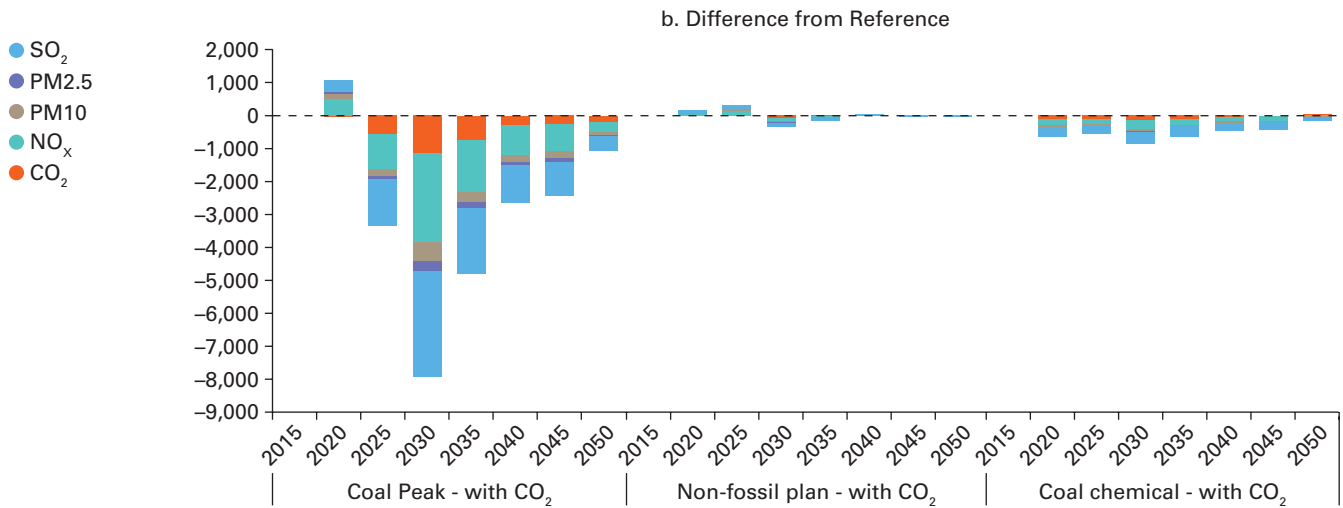

Figure 7.27

Power Sector Emissions, by Pollutant Type: Core Policies with CO₂ (continued)



Note: CO₂ = carbon dioxide; NO_x = nitrogen oxides; PM10 = particulate matter 10; PM2.5 = particulate matter 2.5; SO₂ = sulphur dioxide.

Effect of Climate Change on Water Supply and Thereby the Energy System

Climate change accompanies concerns about the uncertainty of water availability in the future. However, the modeling work done by the Institute for Water and Hydro Resources, shows that the Energy Bases in China are expected to benefit from more—not less—rainfall, although with greater variability. As a result, the energy system could be less water constrained in the Energy Bases, whereas the Other (wet) region will likely experience less rainfall—although not enough to dramatically affect the energy sector.

As figure 7.28 shows, the three representative concentration pathway (RCP) scenarios, varying from 2.6 to 8.5, show a nonsignificant (less than 0.025 percent) effect on overall energy system cost, with little variation between the RCP levels. Figure 7.29 shows that regional shifts in total water use for energy are small, with most reductions in Eastern Inner Mongolia and most additions in the Other region.

Figure 7.28

Total Cumulative System Cost (2010-50) and Difference for the RCP Scenarios

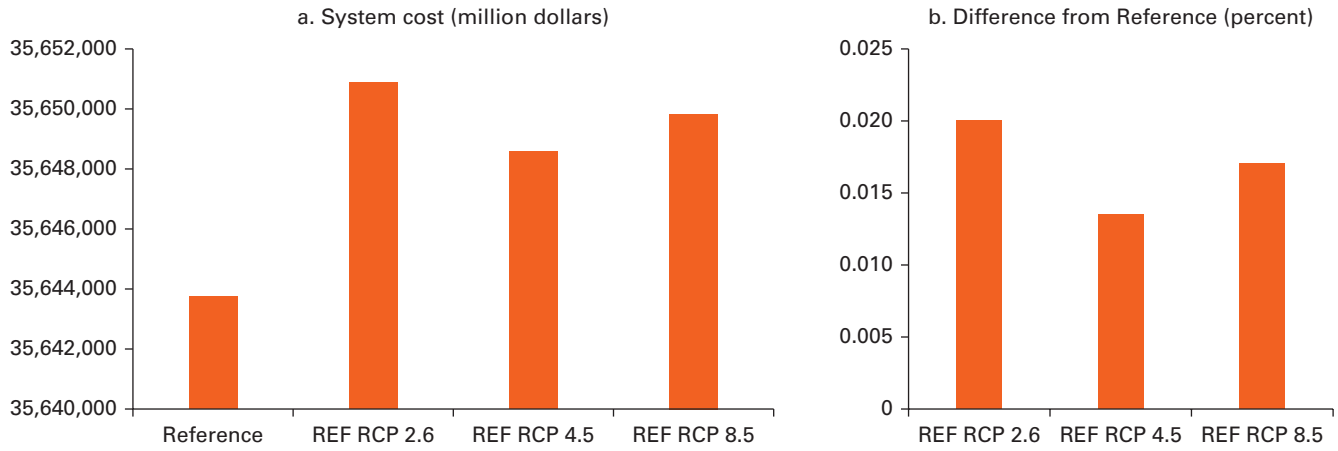

Note: CO₂ = carbon dioxide; RCP = representative concentration pathway.

Figure 7.29

Energy Sector Water Withdrawal and Difference, by Region: Climate Change Cluster

Billion cubic meters

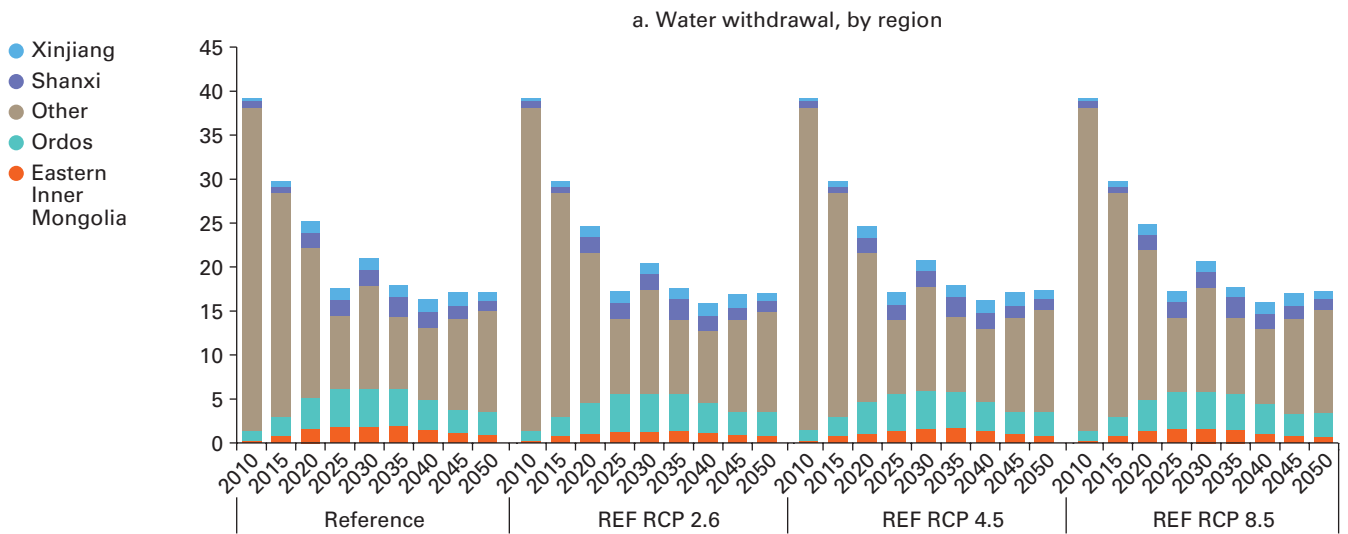

(continued)

Figure 7.29

Energy Sector Water Withdrawal and Difference, by Region: Climate Change Cluster (continued)

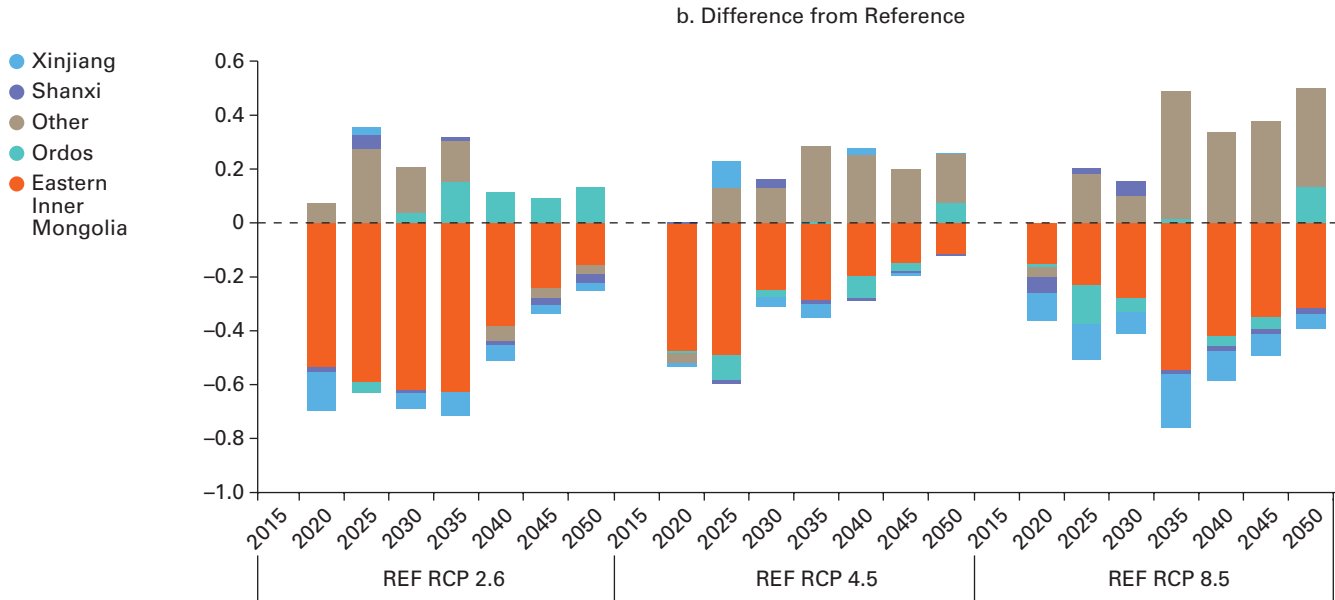

Note: CO₂ = carbon dioxide; RCP = representative concentration pathway; REF = Reference.

Reference versus All Policies: Effect of Water Supply Cost

The All-policies scenario combines the Coal Peak policy, the Non-fossil plan, the Coal chemical policy, and the Shale gas policy with the CO₂ limit (Reference scenario). As figure 7.30 shows, the inclusion of water supply costs to the All-policies scenario increases total system cost 0.36 percent compared with 0.33 percent for the Reference scenario, indicating that the effect of including the cost of water supply is modest in both cases.

The All-policies scenario increases the system costs by 1.27 percent (US\$450 billion) compared with the Reference case, driven primarily by the Coal Peak policy (given that the CO₂ policy is already in the Reference scenario), indicating the additional cost to the energy system to attain all the current policies under consideration at this time.

Figure 7.30

**Total Cumulative System Cost (2010-50) and Difference:
Effect of Water Cost Cluster**

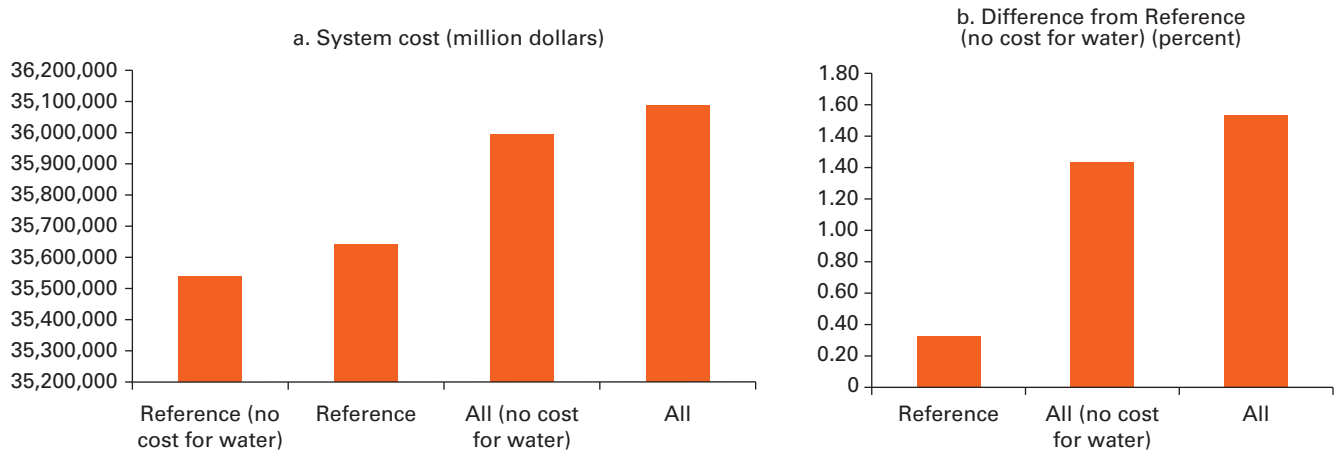

Comparing the All-policies scenario to the combined Coal Peak policy + CO₂ policy shows that the other components of the All-policies scenario add 0.2 percent more cost than the more stringent Coal Peak policy and the CO₂ policy.

Core Policies: Effect of Water Supply Cost and Carbon Dioxide Policy

To better understand the effect of individual core policies, they are examined in figure 7.31 against the Base scenario without considering water supply costs and without imposing the CO₂ policy (Reference scenario). A comparison of figure 7.31 with figure 7.21 shows that whether the cost of water supply is included, the relative effect of the policies on the total energy system cost is basically the same; simply an increase by the \$200 billion of the supply cost for water.

As figure 7.32 shows, the Coal Peak scenario is effective in reducing water withdrawals in the power sector, shifting from coal to nuclear and renewables, regardless of whether water supply cost is considered. The Non-fossil plan scenario is also quite effective, given that renewables and nuclear are promoted and thus coal is phased out. The Coal chemical policy scenario has a more modest effect on water use, showing only minor reductions in the last period. This result indicates that the Coal Peak policy and the Non-fossil plan policy both reduce the water needs by the power sector and accomplish

Figure 7.31

Total Cumulative System Cost (2010–50) and Difference of Core Policy Cases without the Cost of Water

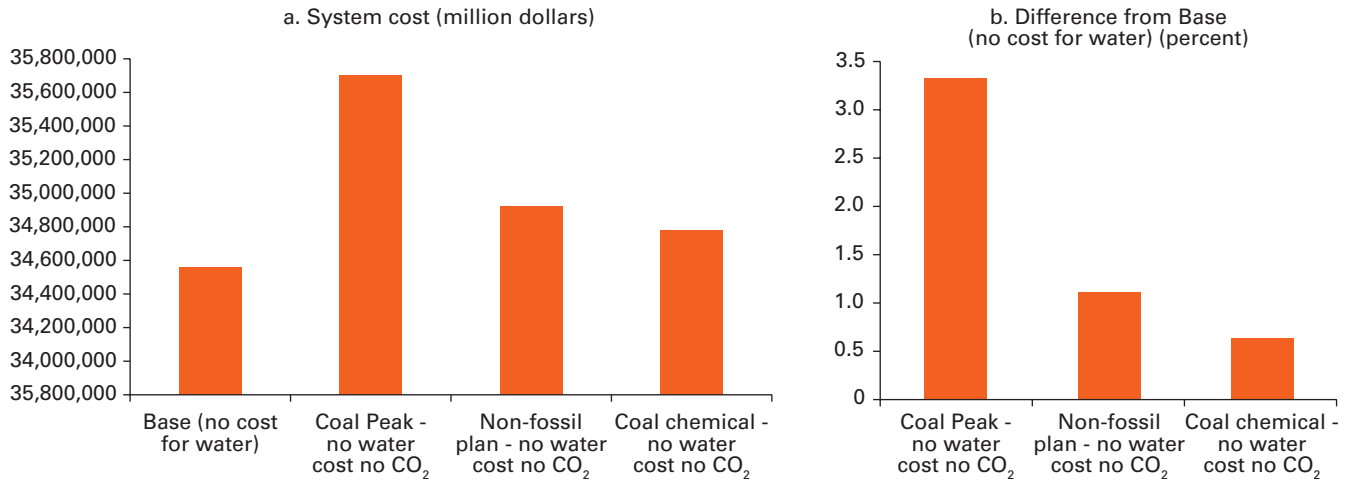

Note: CO₂ = carbon dioxide.

Figure 7.32

Energy Sector Water Withdrawal, by Type: Core Policy Cases without the Cost of Water

Billion cubic meters

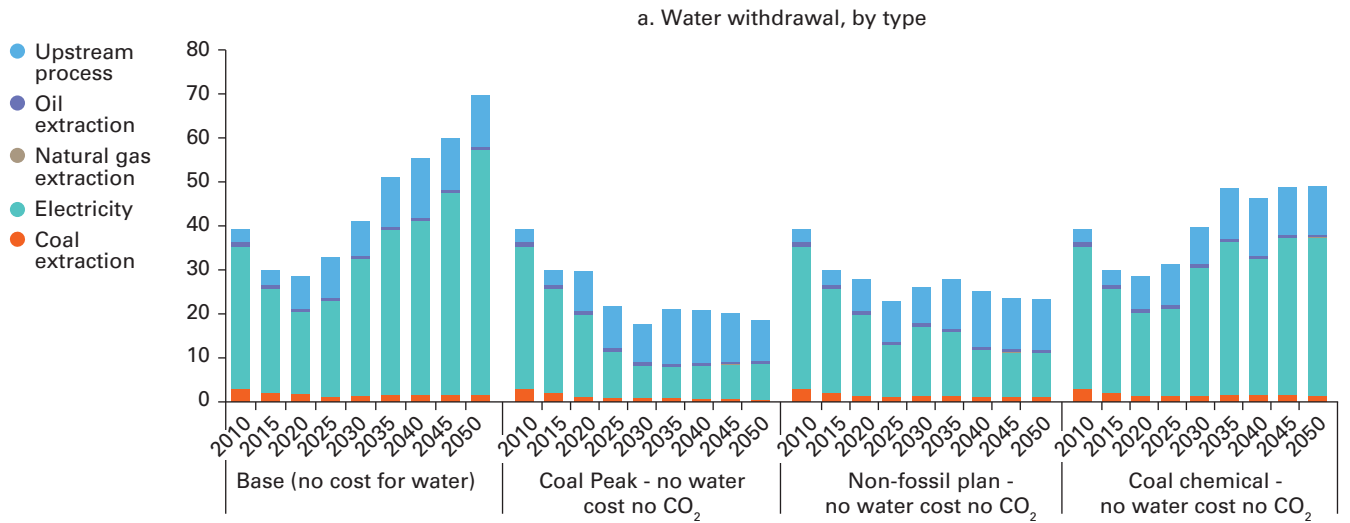

(continued)

Figure 7.32

Energy Sector Water Withdrawal, by Type: Core Policy Cases without the Cost of Water (continued)

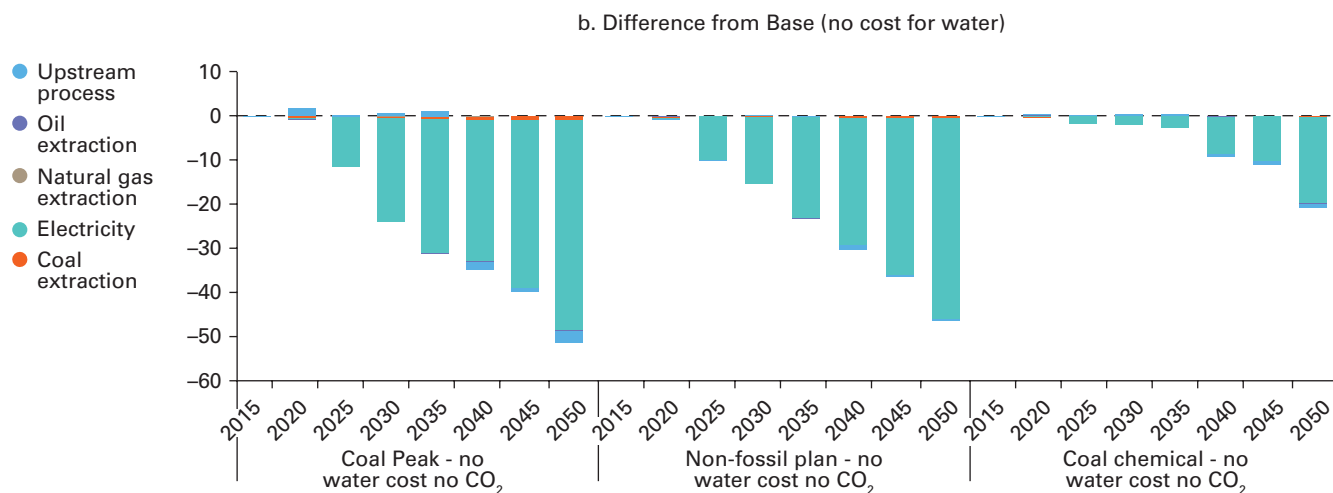

Note: CO₂ = carbon dioxide.

Table 7.5

Costs and Savings of Core Policies

Scenario	Water Savings (billion cubic meters)	Carbon Dioxide Reductions (metric tons)	System Cost Change (million dollars)
Base (no cost for water)	0	0	0
Coal Peak: no water cost, no CO ₂	195	130,486	1,172,988
Non-fossil plan: no water cost, no CO ₂	161	60,963	430,520
Coal chemical: no water cost, no CO ₂	95	1,201	260,394

Note: CO₂ = carbon dioxide.

significant CO₂ reductions. Table 7.5 provides details on the water use savings, CO₂ emission reductions, and energy system cost increases of these policies, highlighting the fact that water savings and CO₂ reductions can go hand in hand. Note that achieving the NDC reduction of CO₂ emissions as required in the Reference and other scenarios, has

an associated marginal cost of \$75/t CO₂ in 2020 and \$578/t CO₂ in 2050, so deeper cuts may prove to be quite challenging and costly.

When the cost of water supply is included, water use in all scenarios is greatly reduced, as shown in figure 7.33.

Figure 7.33 Power Sector Water Withdrawal, by Plant Type: Core Policy Cases with the Cost of Water

Billion cubic meters

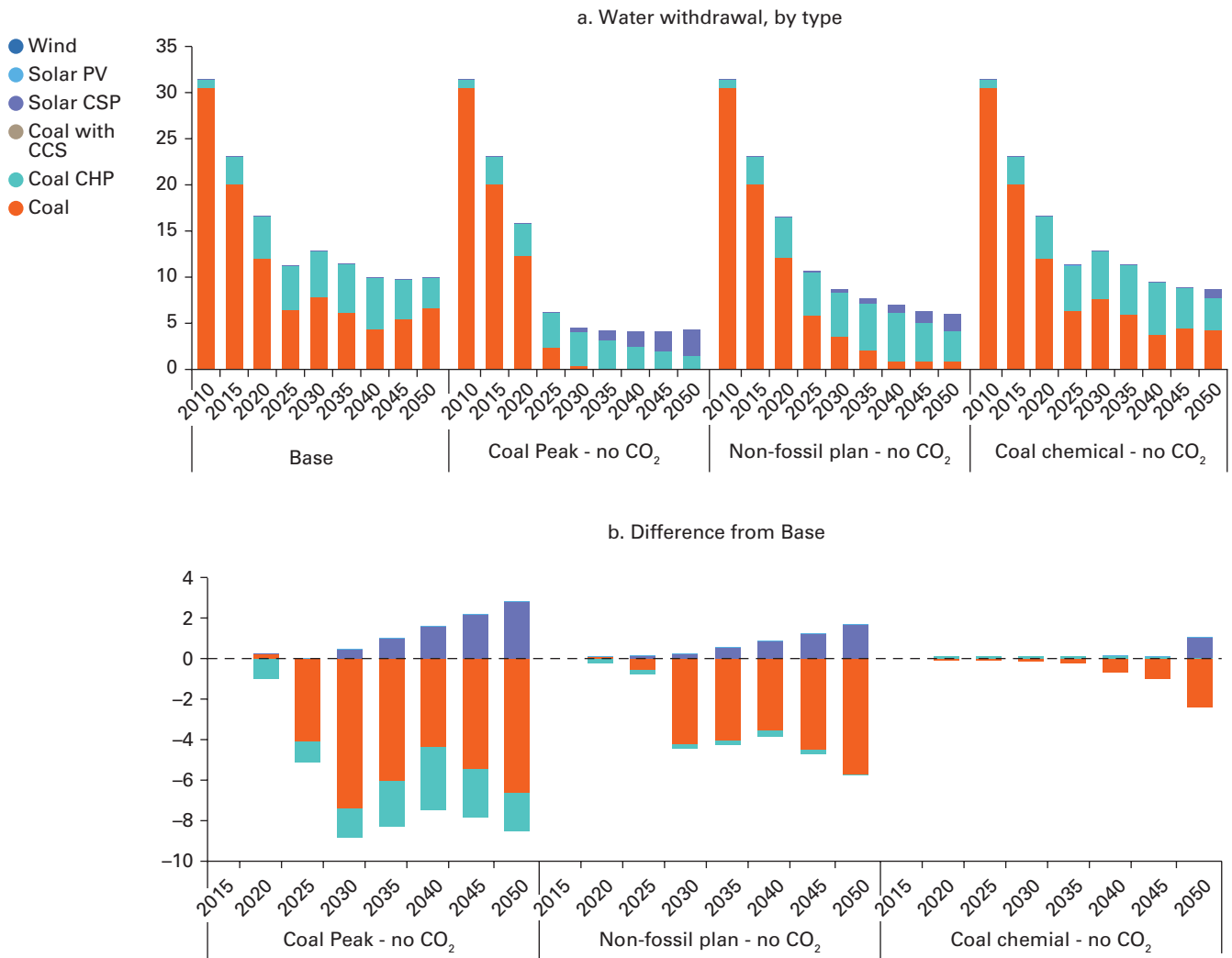

Note: CCS = carbon capture and storage; CHP = combined heat and power; CO₂ = carbon dioxide; CSP = concentrating solar power; PV = photovoltaic; RCP = representative concentration pathway.

Figure 7.34 shows that even without water supply costs and the CO₂ policy, the Coal Peak scenario forces the greatest shift in electricity generation from coal to nuclear, solar, and wind. Compared with figure 7.23, this shows that this result is the same as when the CO₂ policy is included. The Non-fossil policy shows increases in nuclear and renewables, but not as much change as the CO₂ policy in the Reference scenario

Figure 7.34 Electric Generation and Difference, by Type: Core Policy Cases without Water Costs
Terawatt-hours

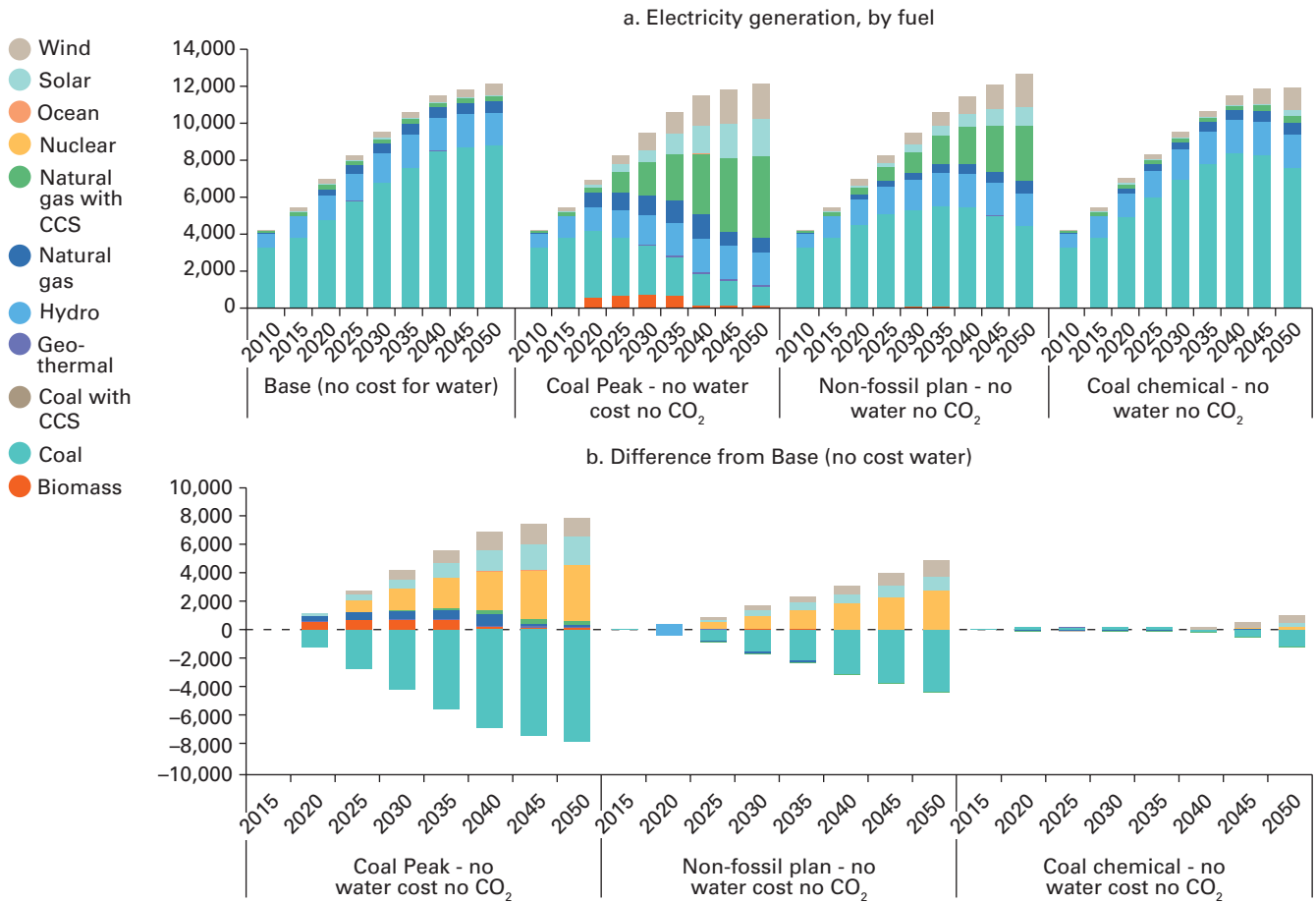

Note: CCS = carbon capture and storage; CO₂ = carbon dioxide.

Figure 7.35

Electricity Generation, by Type: Core Policy Cases without the Cost of Water, 2050

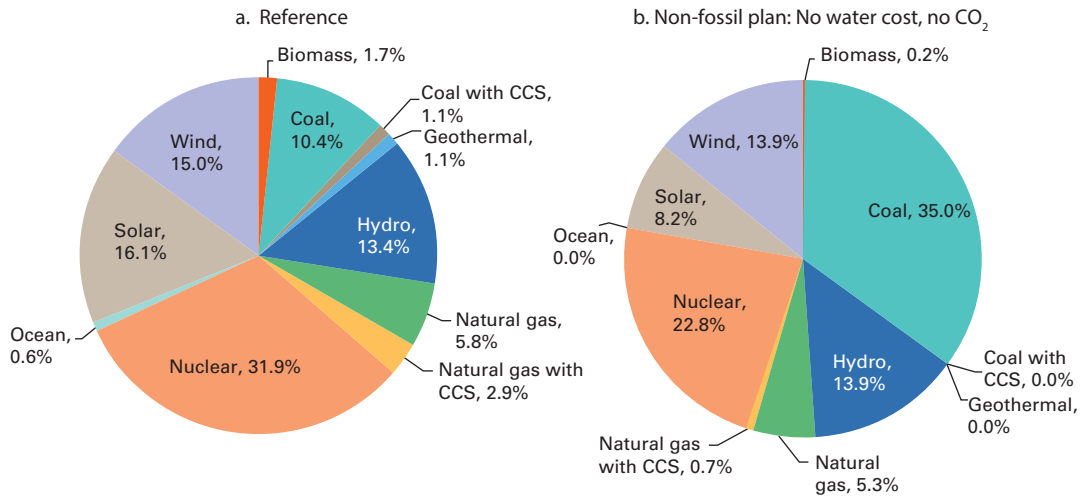

Note: CCS = carbon capture and storage; CO₂ = carbon dioxide.

implements shown in figure 7.35. The Coal chemical policy has the same mix of power plants as the Base scenario. When the cost of water supply is included, there is no change in the electricity generation results shown in figure 7.34.

Figures 7.36 and 7.37 show the effects of these scenarios on the final energy consumption. The Coal Peak policy scenario replaces a large amount of coal with natural gas for direct use, whereas the Non-fossil plan scenario replaces some direct use of gas with electricity from renewables and nuclear. The Coal Peak policy scenario leads to significant efficiency improvements in the building, transportation, and industry sectors; the Non-fossil plan scenario affects buildings and industry, but much later. Meanwhile, the Coal chemical policy scenario has a mixed effect on building energy use.

Figure 7.38 shows that the Coal Peak scenario is the most effective at reducing CO₂ emissions, even without the CO₂ policy in place. The Non-fossil plan scenario is also effective, but the Coal chemical policy scenario is not because it has little effect on the power sector, which produces most of the emissions. These CO₂ emission results show no differences when the cost of water supply is added to the policy scenarios.

Figure 7.36

Final Energy and Change, by Fuel: Core Policy Cases without the Cost of Water

Petajoules

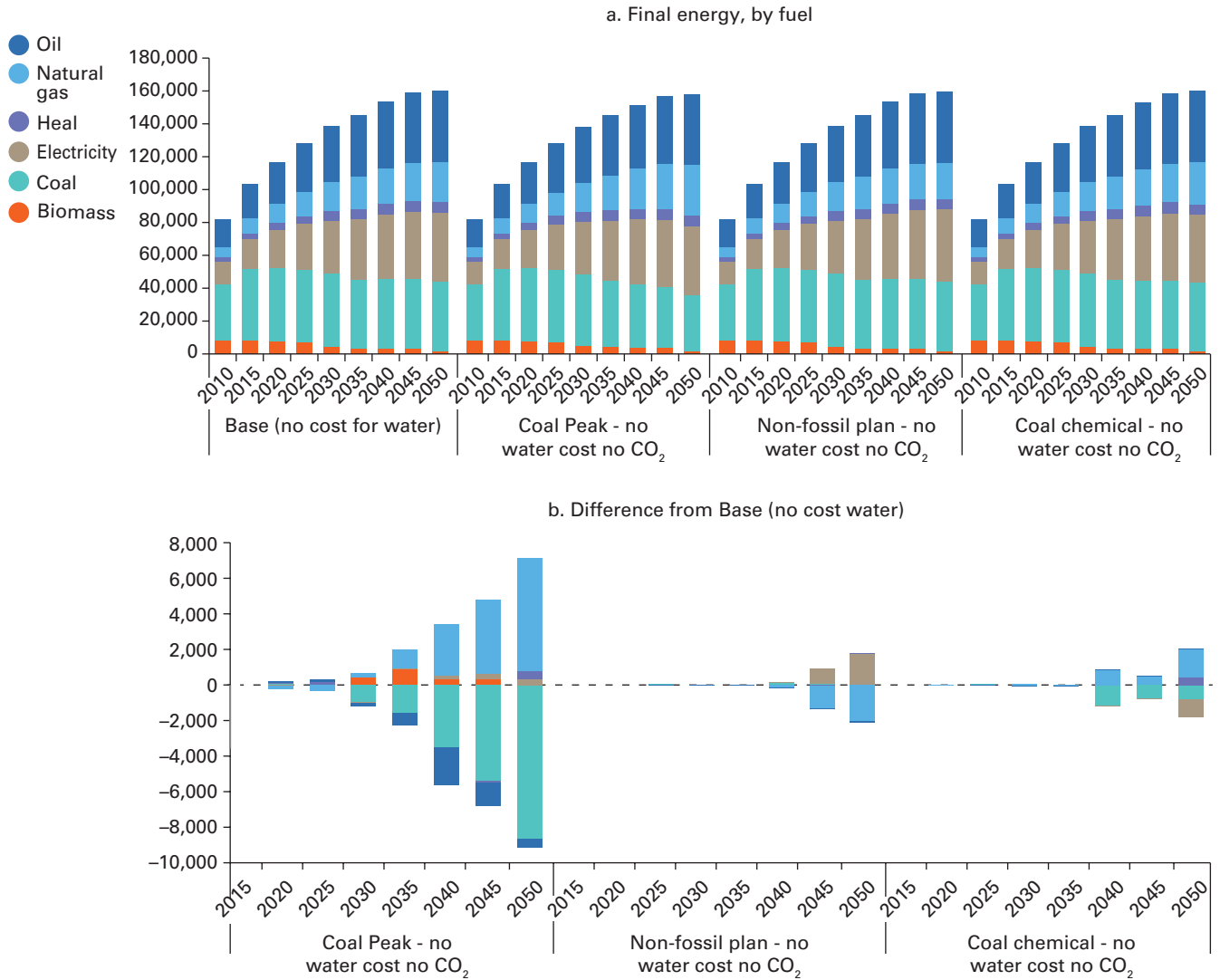

Note: CO₂ = carbon dioxide.

Figure 7.37

Final Energy, by Sector: Core Policy Cases without the Cost of Water

Petajoules

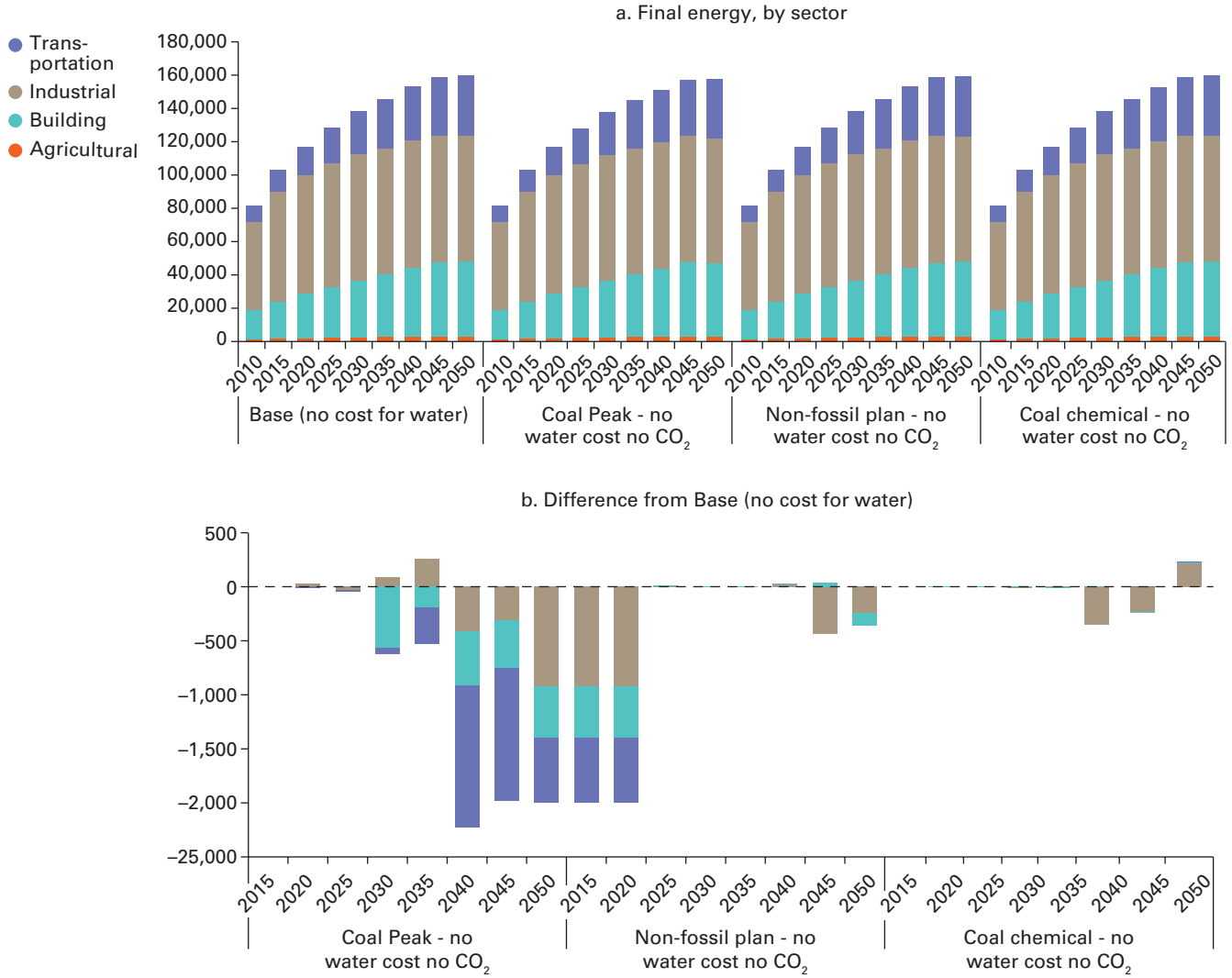
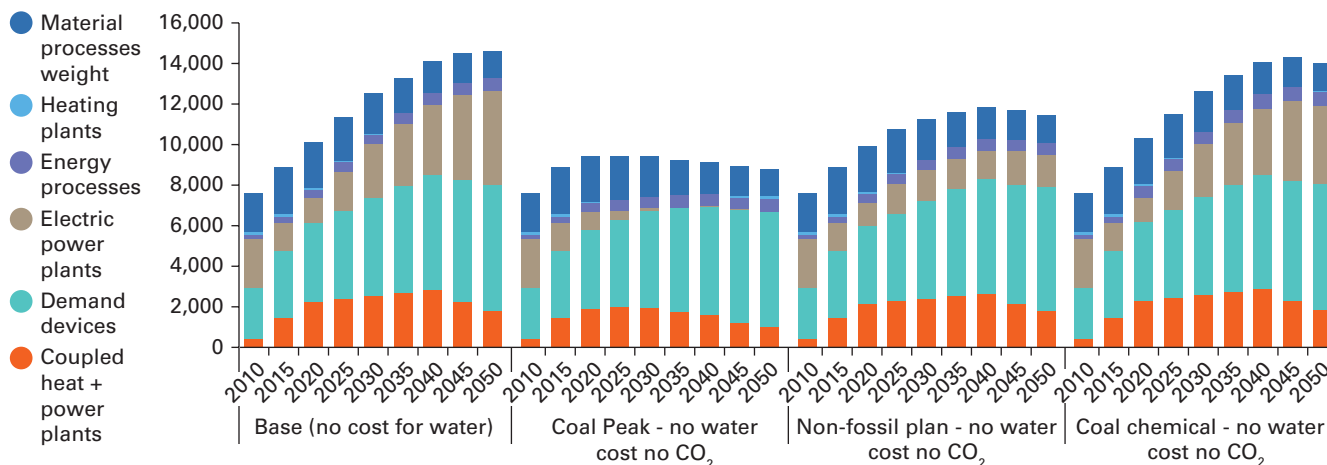

Figure 7.38

CO₂ Emissions, by Sector: Core Policy Cases without the Cost of Water

Million metric tons



Note: CO₂ = carbon dioxide.

Coal Peak versus Carbon Dioxide Policy

The two most stringent policies are the Coal Peak and CO₂ limit, and this section examines each in more detail to understand how each affects the system and how they interplay with each other. As figure 7.39 shows, the Coal Peak scenario is the more costly of the two, but the combined Coal Peak policy and CO₂ policy is the most costly of all.

The Coal Peak scenario has higher costs because it forces earlier investments into nuclear and renewable power plant builds, retiring coal power plants that are kept operating longer in the Reference scenario. The change in new power plant builds in figure 7.40 shows that the Coal Peak scenario without the CO₂ policy requires greater investments in nuclear, gas, solar and wind capacities through 2030, but after that the Reference scenario has greater investment needs. However, the discounting of future costs means that the effect of later investments on the systems cost is less significant than the earlier ones. The combined Coal Peak and CO₂ scenario has the same coal plant retirements as the Coal Peak scenario and the same level of nuclear, gas, and renewable capacity additions as the CO₂ policy (Reference scenario) alone. Note that much of the additional Non-fossil capacity in the Coal Peak scenario comes from biomass as well as solar and wind.

Figure 7.41 shows the difference in CO₂ emissions by energy process type compared with the Base scenario. It clearly shows that the Coal Peak scenario alone results in

Figure 7.39

Total Cumulative System Cost (2010–50) and Difference: Coal Peak versus CO₂ Policy Cluster

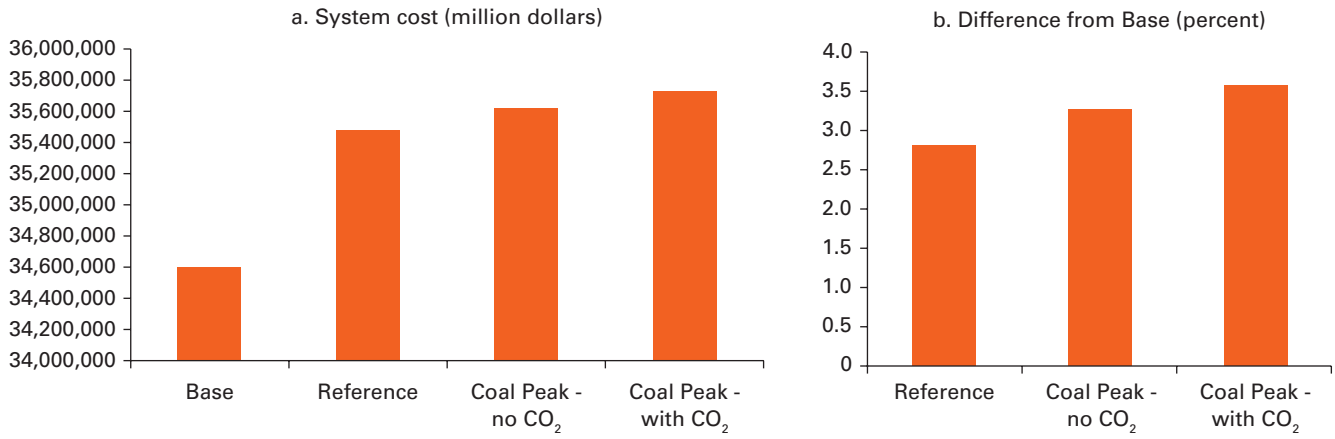

Note: CO₂ = carbon dioxide.

Figure 7.40

Change in New Power Plant Builds: Coal Peak versus CO₂ Policy Cluster

Gigawatts

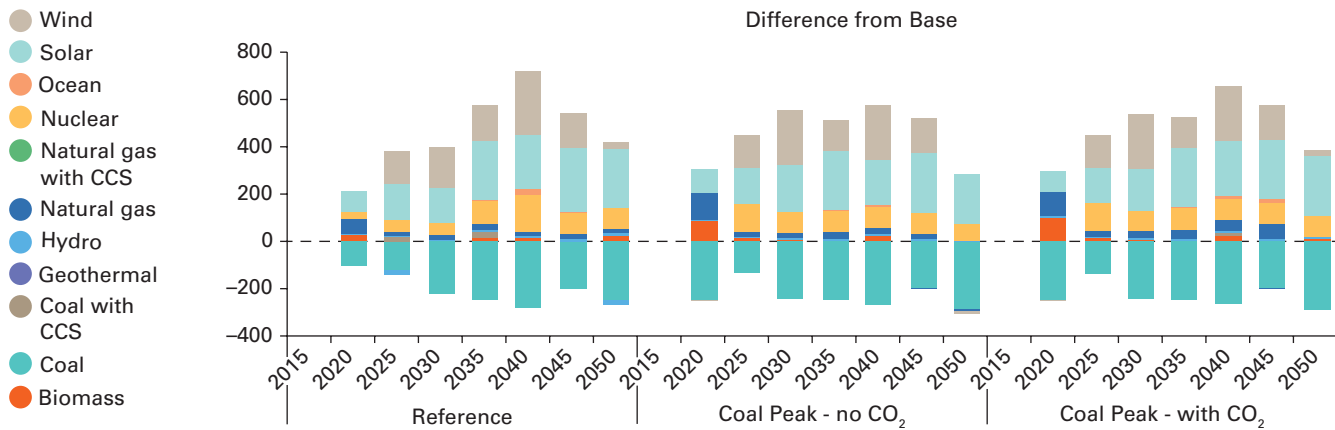

Note: CCS = carbon capture and storage; CO₂ = carbon dioxide.

Figure 7.41

Change in CO₂ Reductions: Coal Peak versus CO₂ Policy Cluster (difference from Base)

Million metric tons

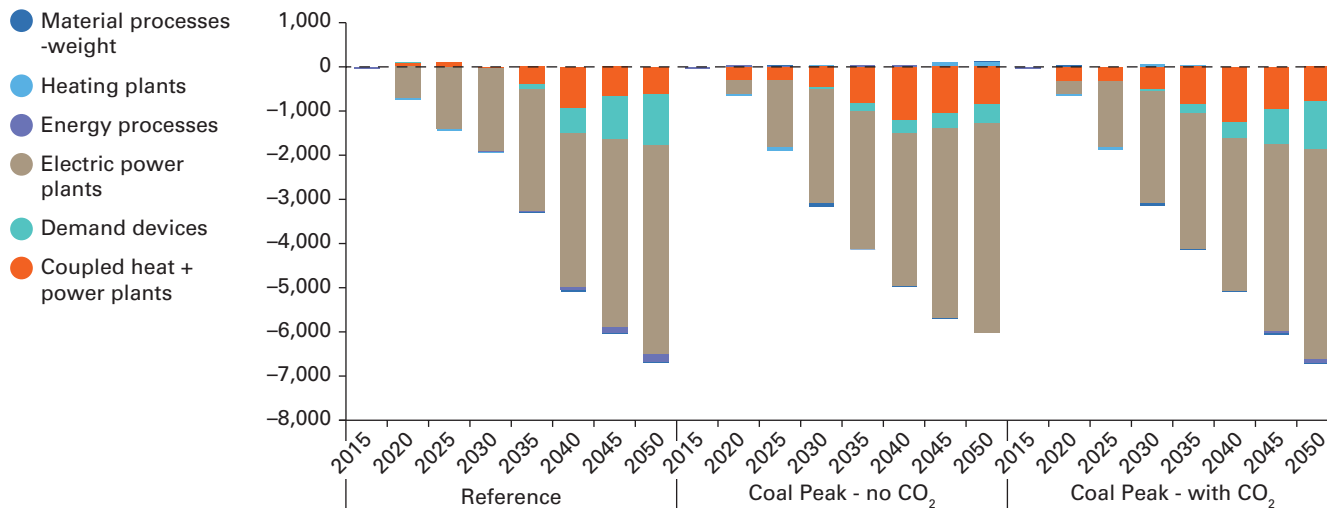

Note: CO₂ = carbon dioxide.

Table 7.6

Relative Change in Carbon Dioxide Emissions: Coal Peak versus Carbon Dioxide Policy Cluster

Percent

Scenario	Growth from 2010	Drop in 2050 Level	Cumulative Reduction versus Base
Base	92.5	0.0	0.0
Reference (CO ₂ policy)	4.8	-45.5	-24.0
Coal Peak: no CO ₂ policy	15.5	-40.0	-25.3
Coal Peak: with CO ₂ policy	4.8	-45.5	-26.6

Note: CO₂ = carbon dioxide.

larger reductions early, though with lower levels in the last decade. The combined case has both the greater early reductions as well as the higher reductions in the last decade.

Table 7.6 shows the relative change in CO₂ emissions for the CO₂ policy (Reference scenario) versus Coal Peak and Combined scenarios. The Coal Peak policy alone achieves a 5.5 percent decrease in cumulative CO₂ reductions compared with the CO₂

only policy (Reference) but with an incrementally higher cost. The combined policy decreases the cumulative CO₂ emissions by almost 11 percent.

Non-Fossil Plan versus Non-Fossil Policy

The Non-fossil plan requires a specified series of capacity additions of nuclear and renewable technologies according to the government’s official plan, both with respect to the timing and the amount of new capacity. In contrast, the Non-fossil policy achieves the same percentage of electricity generation from Non-fossil technologies (nuclear and renewables) but does so by allowing the model to determine the mix and timing of these new capacity investments. As seen in figure 7.42, the Non-fossil policy results in a 0.7 percent lower system cost than in the Non-fossil plan.

The main difference between the two scenarios is that in the Non-fossil policy scenario, the choice and timing of the new capacity additions is determined by TIMES-ChinaW. When the Non-fossil plan or Non-fossil policy are combined with the CO₂ constraint, the Non-fossil plan will lead to the earlier introduction of wind and solar CSP power plant, as shown in figure 7.43, which does impose a small increase in system cost but adds a greater variety of renewables in the Energy Bases compared with the Non-fossil policy, which selects mostly CSP in the Other regions because it is the lowest cost renewables option. Because the Non-fossil plan builds more renewable energy capacity in the Energy Bases, it increases water withdrawals and consumption, but by less than 1 percent (see figure 7.44).

Figure 7.42 Total Cumulative System Cost (2010–50) and Difference: Non-Fossil Plan versus Non-Fossil Policy

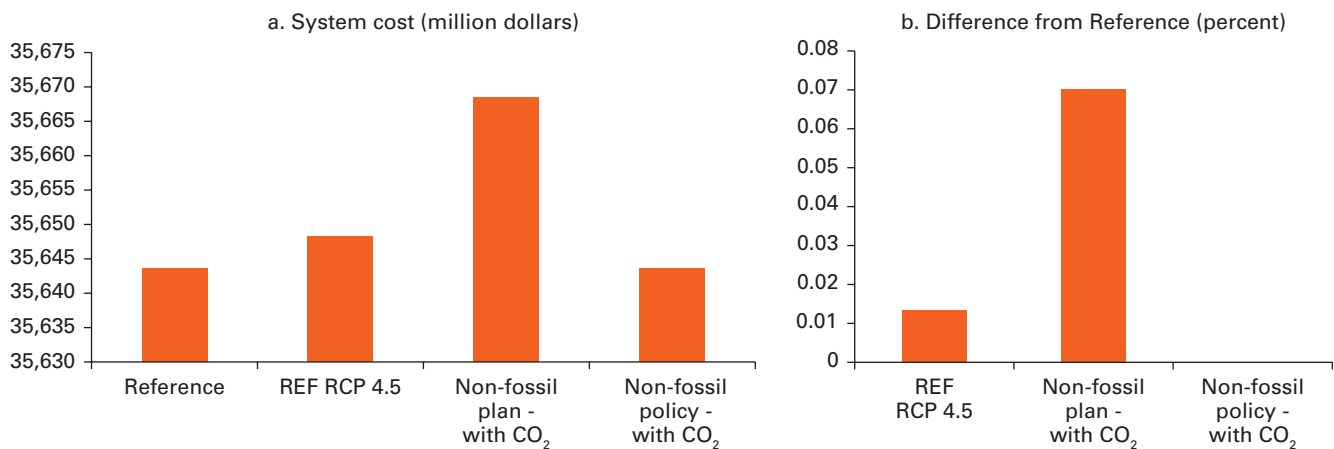

Note: CO₂ = carbon dioxide; RCP = representative concentration pathway.

Figure 7.43

Change in Electricity Capacity: Non-Fossil Plan versus Non-Fossil Policy Cluster

Gigawatts

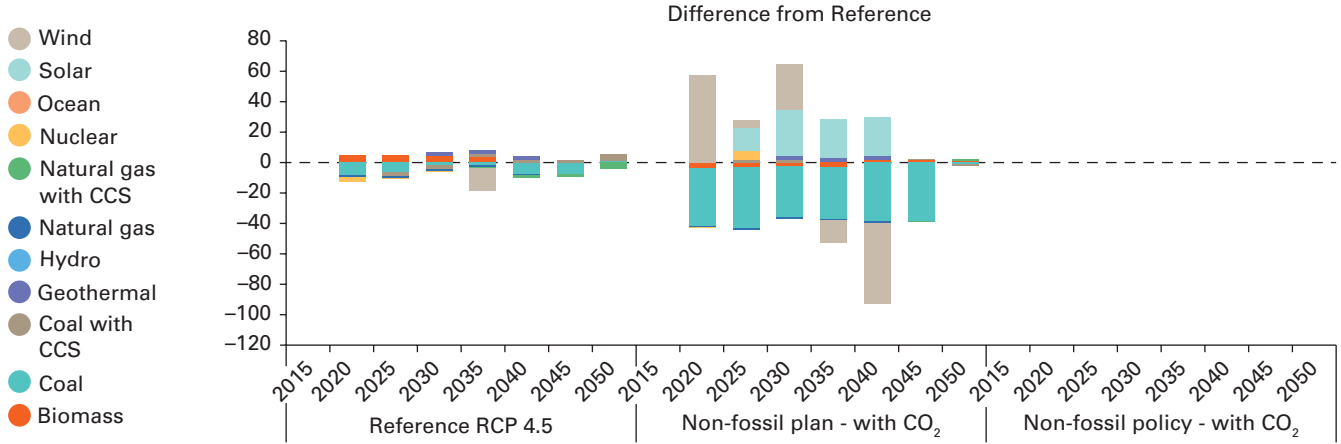
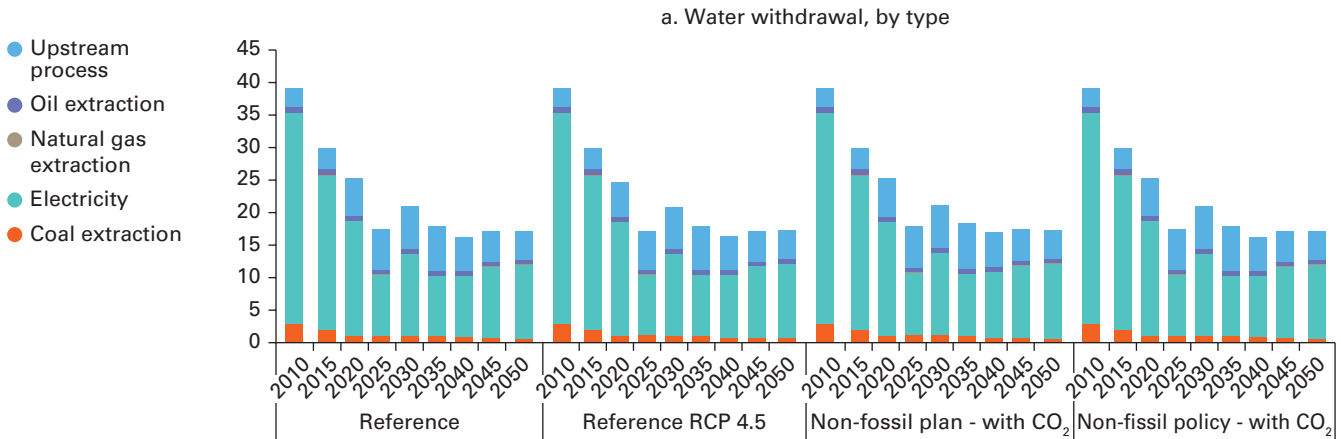

Figure 7.44

Energy Sector Water Withdrawal and Consumption, by Type: Non-Fossil Plan versus Non-Fossil Policy Cluster

Billion cubic meters



(continued)

Figure 7.44

Energy Sector Water Withdrawal and Consumption, by Type: Non-Fossil Plan versus Non-Fossil Policy Cluster (continued)

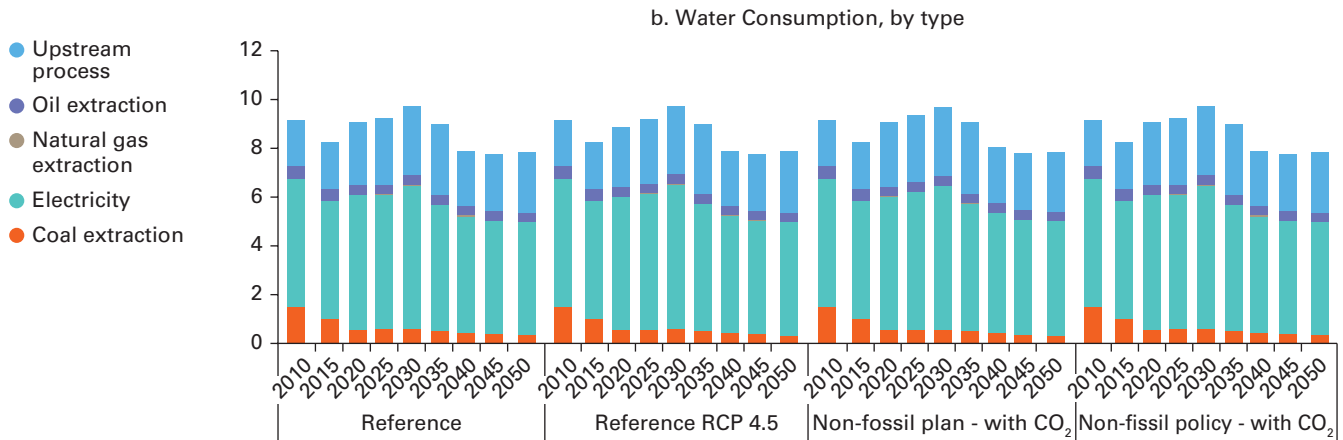

Note: CO₂ = carbon dioxide; RCP = representative concentration pathway.

When combined with the CO₂ constraint, the effects of the Non-fossil plan and the Non-fossil policy are overshadowed by the effects of the CO₂ constraint, which means that to realize the CO₂ constraint, the Non-fossil plan or Non-fossil policy can be achieved at the same time.

Comparison of the Non-fossil plan and Non-fossil policy with the Base scenario can tell the effect of these two scenarios separated from the CO₂ constraint. Figure 7.45 shows that the water consumption of the Non-fossil plan is less than that of the Non-fossil policy, given that the Non-fossil plan replaces more coal power generation by wind and solar (see figure 7.46).

The impacts of climate change are represented in this analysis by the three RCP levels used by Institute for Water and Hydro Resources to develop alternative water supply cost curves. This section focuses on the changes between the Reference and the All-policies scenarios, with the BAU and the RCP8.5 water supply cost curve. Figure 7.47 shows that the all-policies scenario increase total system costs by almost 1 percent for both the water supply cost curves.

As Figure 7.48 shows, the All-policies scenario reduces water withdrawals for electricity generation and upstream processes. It also shows that the RCP8.5 scenario has little effect on water withdrawal—in either the reference or the all-policies scenario. Figure 7.49 shows the changes in electricity generation for the all-policies scenario with the increased generation from nuclear, gas and renewables, and the reductions in all types of coal use.

Figure 7.45

Water Consumption, by Type: Non-Fossil Plan versus Non-Fossil Policy Cluster

Billion cubic meters

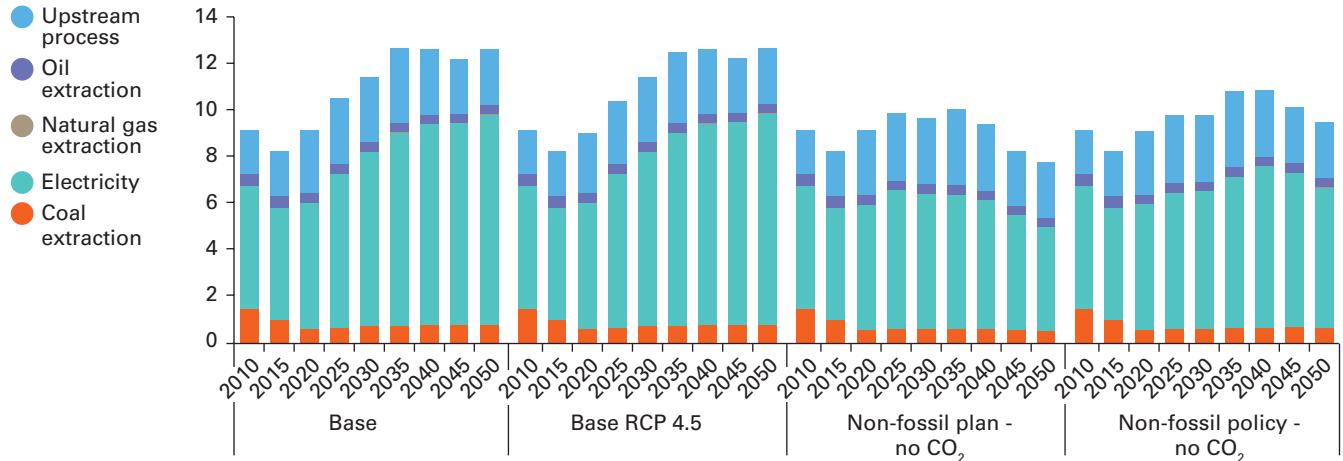

Note: CO₂ = carbon dioxide; RCP = representative concentration pathway.

Figure 7.46

Electricity Generation, by Fuel: Non-Fossil Plan versus Non-Fossil Policy Cluster

Terawatt-hours

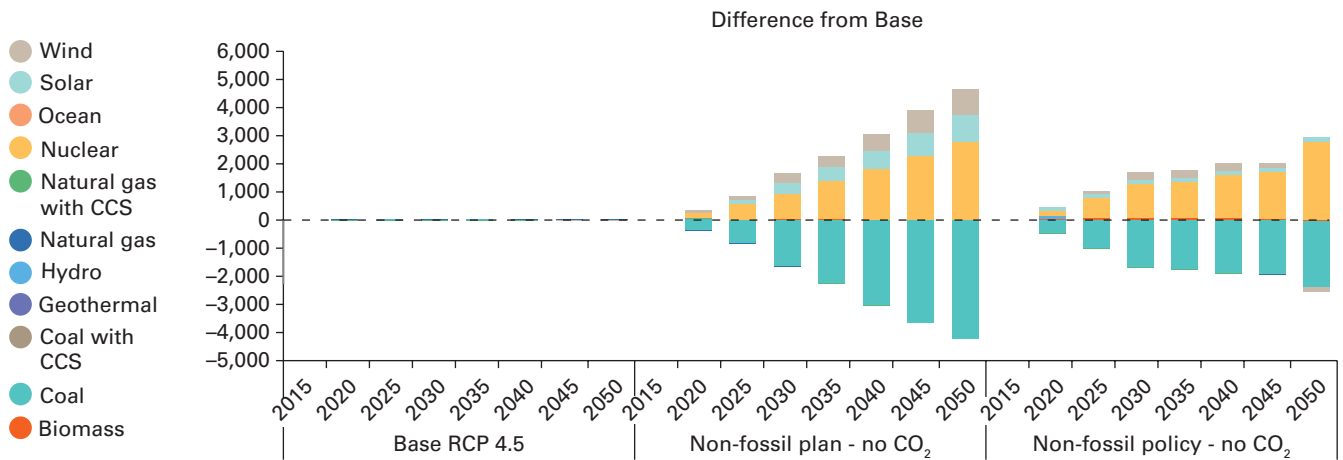

Note: CCS = carbon capture and storage; CO₂ = carbon dioxide; RCP = representative concentration pathway.

Figure 7.47

Total Cumulative System Cost (2010-50) and Difference: All versus Reference Impact of Climate Change Cluster

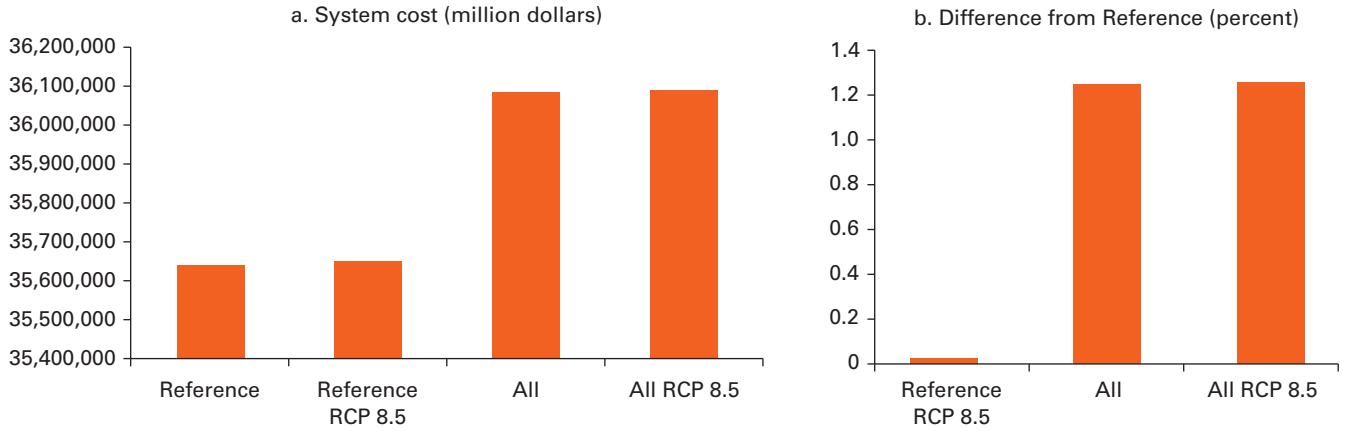

Note: RCP = representative concentration pathway.

Figure 7.48

Energy Sector Water Withdrawal and Difference, by Type: All versus Reference Climate Change Cluster

Billion cubic meters

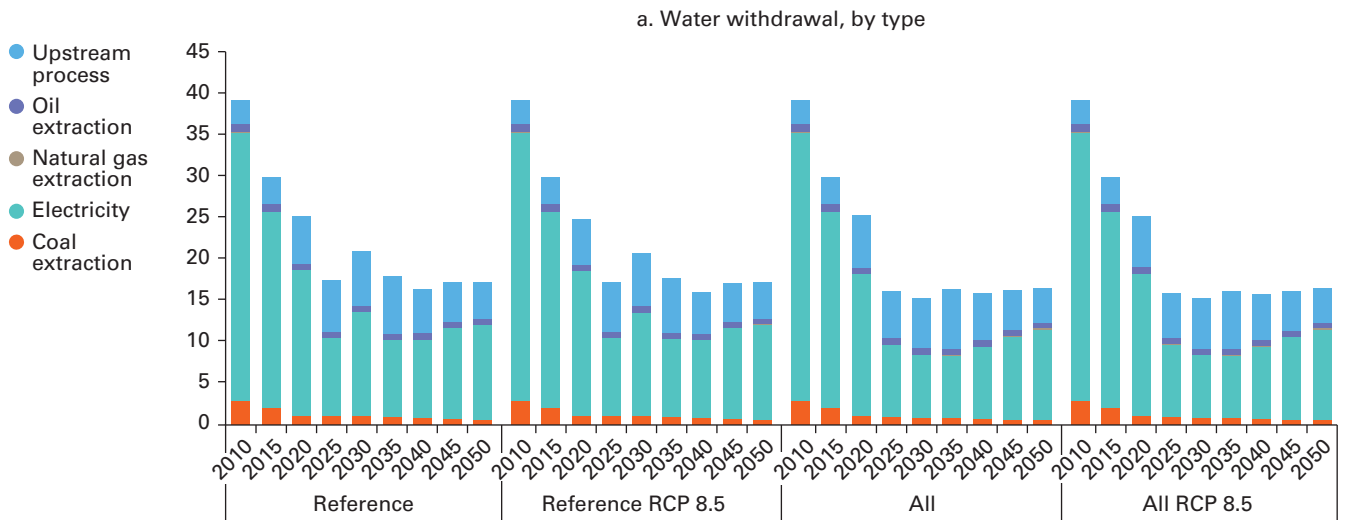

(continued)

Figure 7.48

Energy Sector Water Withdrawal and Difference, by Type: All versus Reference Climate Change Cluster (continued)

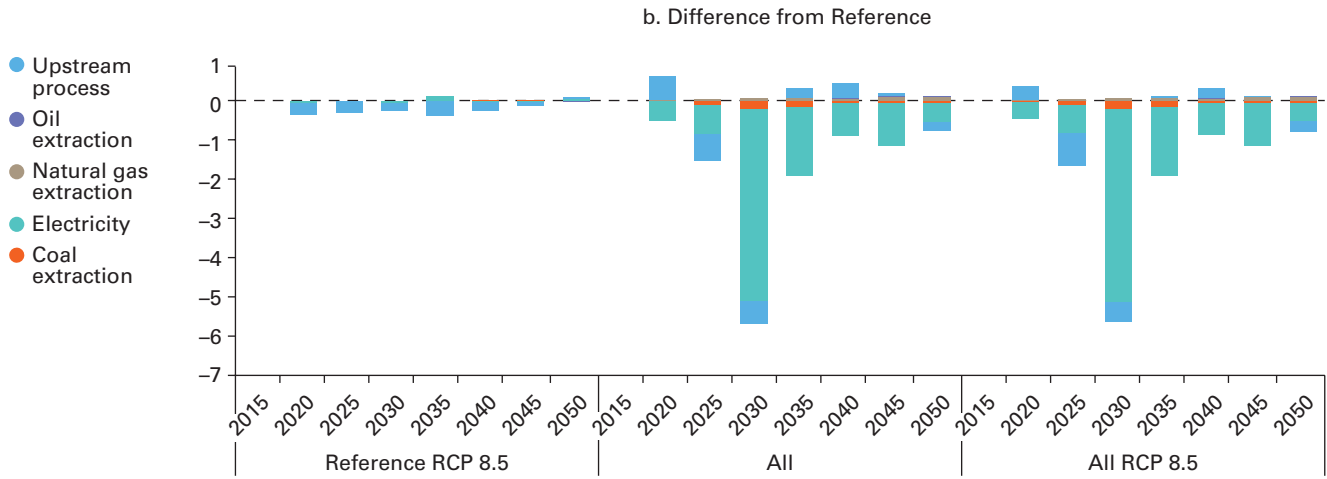

Note: RCP = representative concentration pathway.

Figure 7.49

Electricity Generation and Difference, by Type: All versus Reference Climate Change Cluster
Terawatt-hours

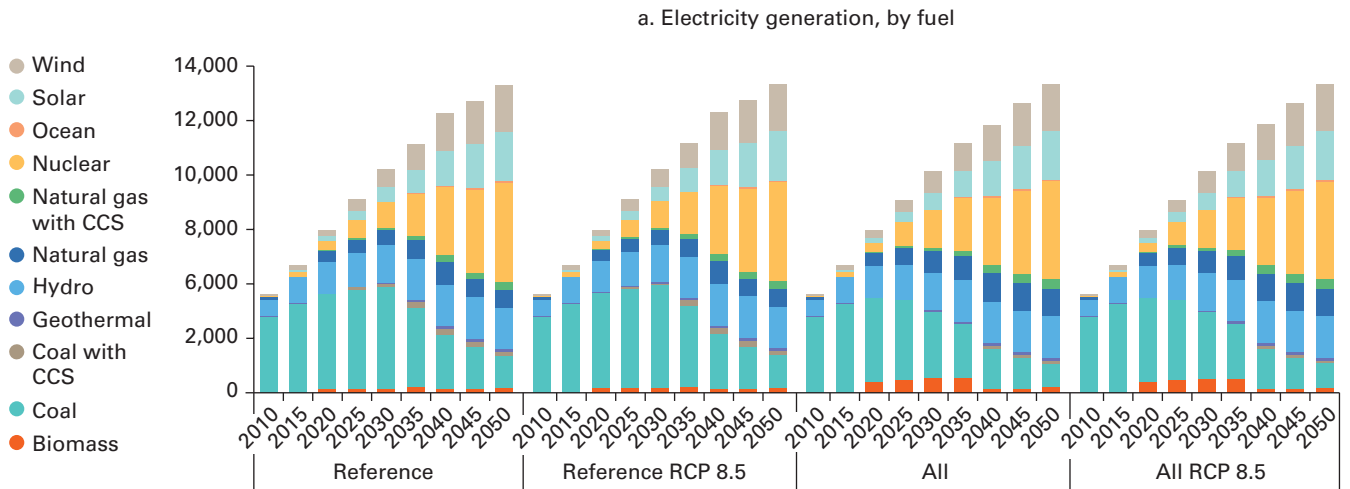

(continued)

Figure 7.49

Electricity Generation and Difference, by Type: All versus Reference Climate Change Cluster (continued)

Terawatt-hours

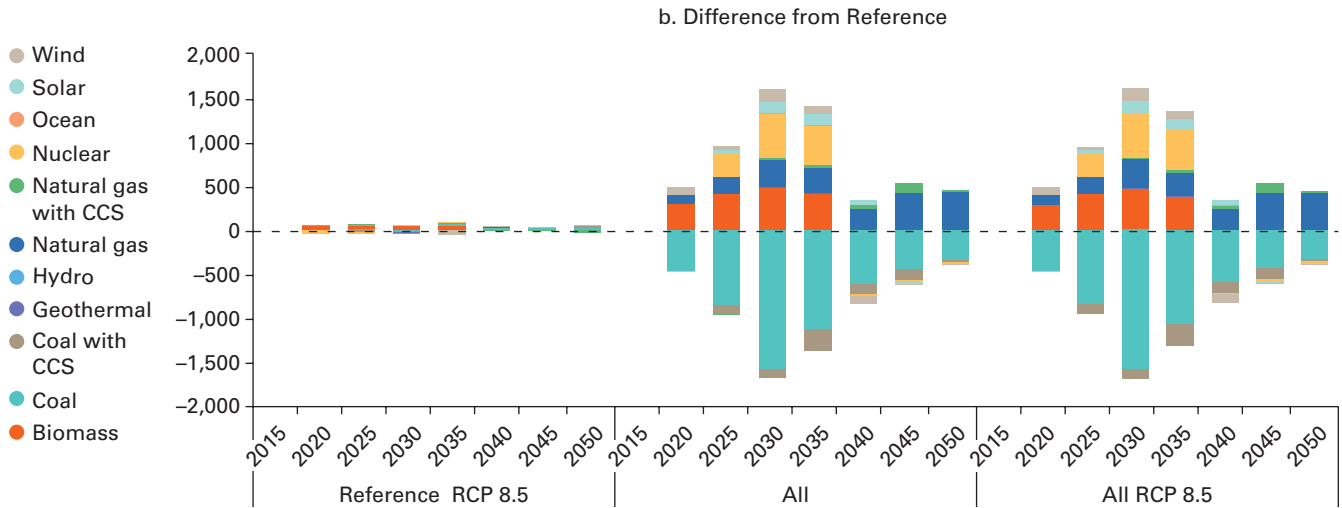

Note: CCS = carbon capture and storage; RCP = representative concentration pathway.

The effect in terms of the energy sector meeting the water 3 Red Lines policies arising from the All-policies scenario include the following:

- Water withdrawal by the energy sector is lowered by 49 percent in 2030, from 29.83 billion m³ in 2015 to 15.25 billion m³, contributing to meeting the target of the red line for total withdrawal control before 2030, with withdrawals remaining low at 16.59 billion m³ in 2050 (44 percent) because of the adoption Non-fossil generation that require no or less water such as wind and solar photovoltaic (PV) and the reduction of coal to liquids in upstream.
- For similar reasons, waste water releases drop from 21.59 billion m³ in 2015 to 6.6 billion m³ in 2030 (69 percent), although then raising slightly to 9.15 billion m³ in 2050 (still a reduction of 58 percent from current levels) helping to address the water quality red line.
- Water consumption by the energy sector increases from 8.24 billion m³ in 2015 to 8.65 billion m³ (5 percent) in 2030 because of the substitution of backward coal once-through power plants by new ones using recirculating cooling, later decreasing to 7.41 billion m³ (10 percent) in 2050 because of the substitution of coal power plant by Non-fossil generation that require less or no water.

- The intensity of water withdrawal for energy per unit of GDP moves from 8.42 m³ per thousand US dollars to 2.31 m³ per thousand US dollars, which is a relative index in line with the red line for controlling the water withdrawal per unit of industrial added value.

Figure 7.50 shows that the All-policies scenarios reduces CO₂ emissions from the power sector compared with the Reference scenario. It also highlights the tradeoff between demand device emissions and power sector emissions that occurs in the All-policies cases, reflecting the increased electricity price and resulting fuel switching due to the faster retirement of existing coal plants and the increased investment in nuclear, gas and renewable plants.

Figure 7.51 shows the resulting changes in primary energy use for the All-policies scenario compared with the Reference scenario, and it highlights the reduction in coal use and the increase in nuclear and renewables. Figure 7.52 shows additional reduction in domestic production of coal in the All-policies scenario. Domestic gas production decreases slightly, and oil demand is met through increased imports rather than

Figure 7.50 CO₂ Emissions and Change: All versus Reference Climate Change Cluster
Million metric tons

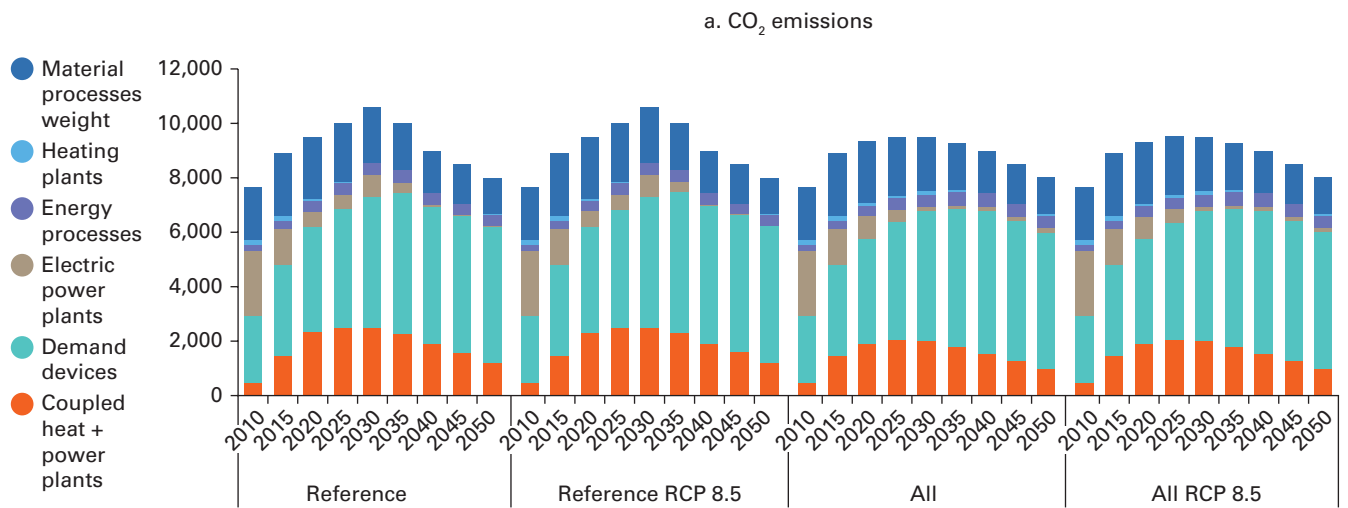

(continued)

Figure 7.50

CO₂ Emissions and Change: All versus Reference Climate Change Cluster (continued)

Million metric tons

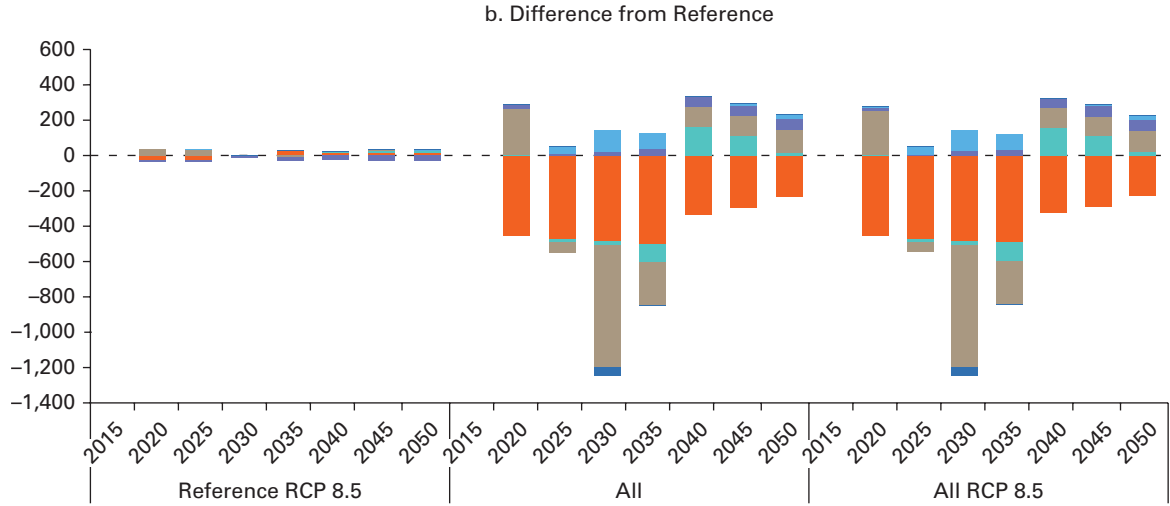

Note: CO₂ = carbon dioxide; RCP = representative concentration pathway.

Figure 7.51

Primary Energy Supply and Change: All versus Reference Climate Change Cluster

Petajoules

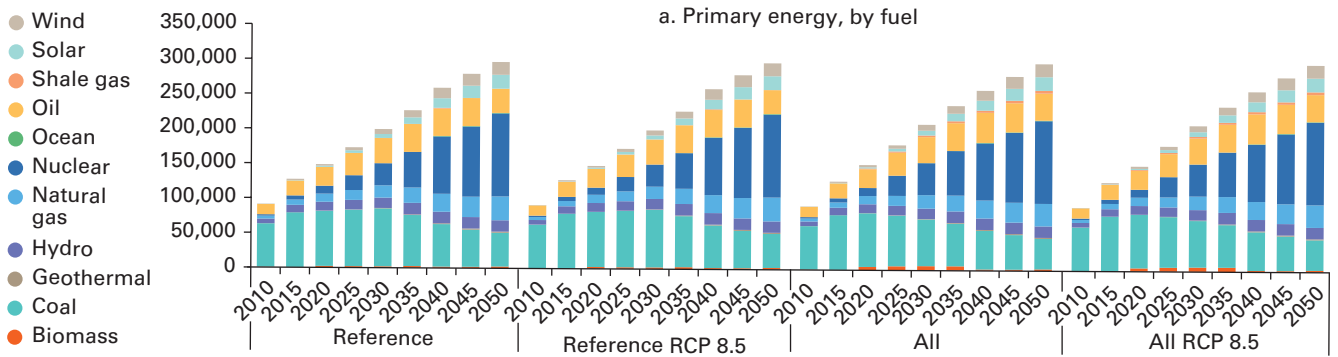

(continued)

Figure 7.51

**Primary Energy Supply and Change: All versus Reference
Climate Change Cluster (continued)**

Petajoules

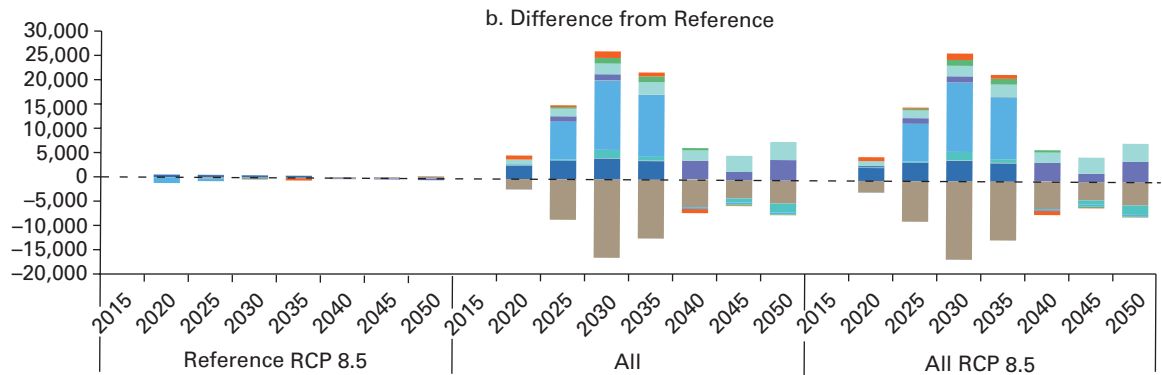

Note: RCP = representative concentration pathway.

Figure 7.52

**Change in Imports and Domestic Production: All versus Reference
Climate Change Cluster**

Petajoules

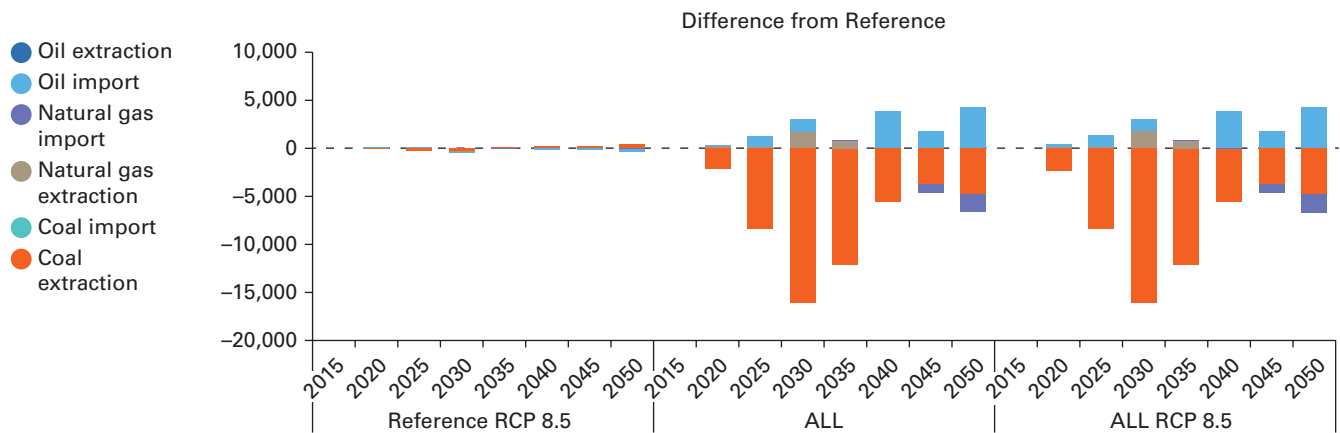

Note: RCP = representative concentration pathway.

domestic refinery products. Figure 7.53 shows that under the all-policies scenarios, the final energy consumption in transportation and building sector will shift from electricity to natural gas. Meanwhile, the system will import more oil instead of operating the oil refinery or coal chemical conversion plants.

As seen in figure 7.54, the All-policies scenario increases power plant investments between now and 2030 because of the faster action required by the Coal Peak scenario, which forces down coal use in 2020, resulting in the introduction of more nuclear, biomass, wind, and solar. Figure 7.55 shows the change in the regional patterns of electricity generation between the All-policies and the reference scenario. In the years before 2035, the increase in nuclear and biomass generation will take place in the Other region, and in later periods solar and natural gas generation will be increased in Ordos.

Figure 7.53 Change in Final Energy Consumption, by Sector: All versus Reference Climate Change Cluster
Petajoules

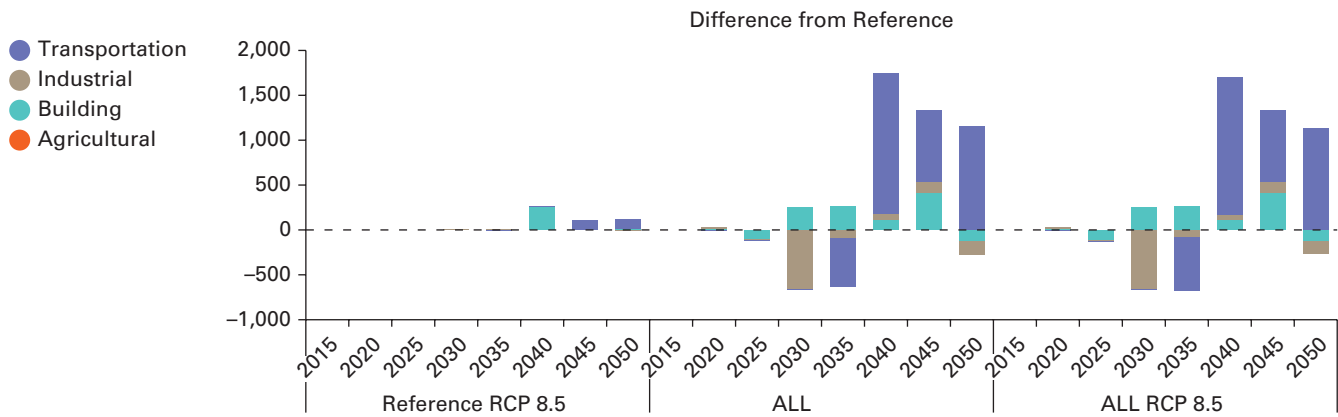

Note: RCP = representative concentration pathway.

Figure 7.54

Change in Power Plant Builds: All versus Reference Climate Change Cluster

Gigawatts

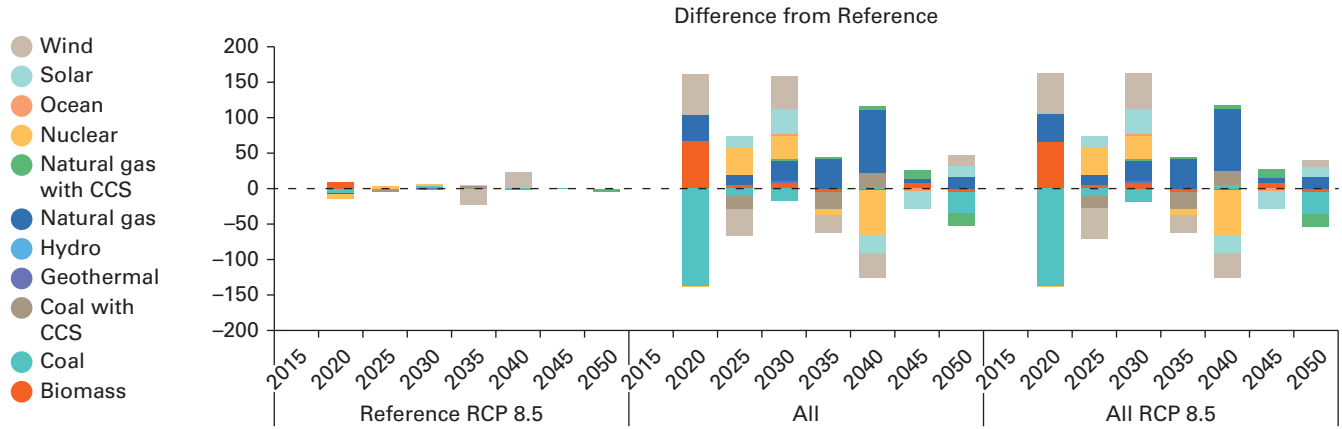

Note: CCS = carbon capture and storage; RCP = representative concentration pathway.

Figure 7.55

Shift in Regional Electricity Generation: All versus Reference Climate Change Cluster

Terawatt-hours

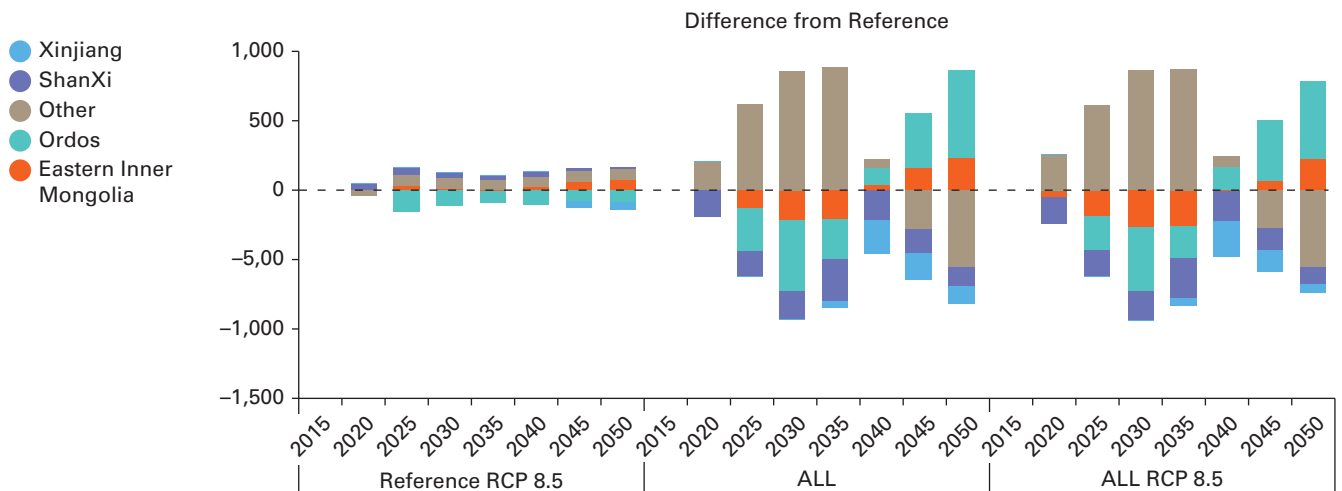
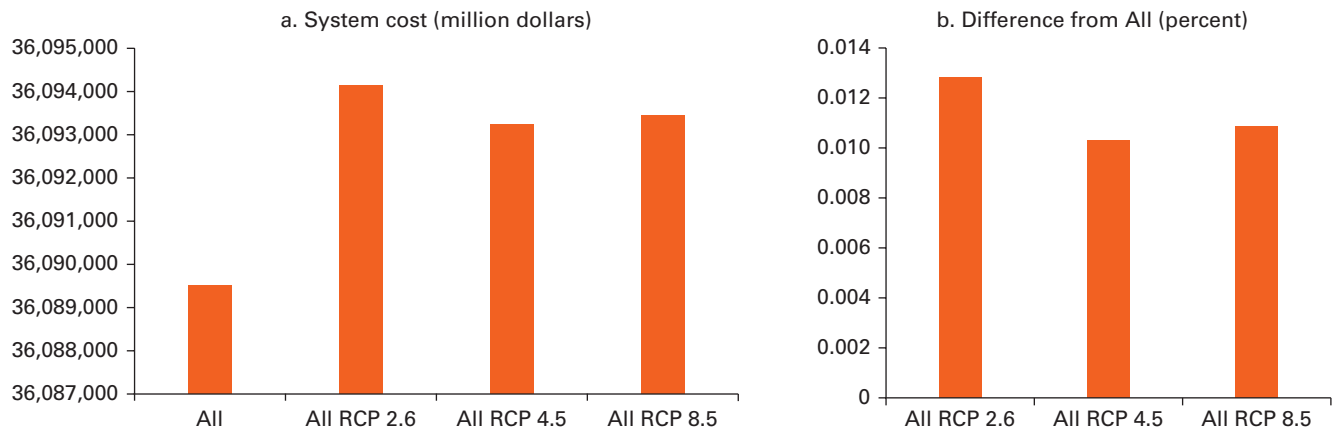

Figure 7.56

Total Cumulative System Cost (2010–50) and Difference: All Policies Climate Change Cluster



Note: RCP = representative concentration pathway.

All Policies: Effect of Climate Change

The Institute for Water and Hydro Resources' water model shows that the potential impacts of climate change on these Energy Bases results in them receiving more rainfall (although with greater variation) as estimated by the climate model used, whereas the water-rich Other region will see marginally less rainfall but not enough to influence the supply.

As a result, the changes in the All-policies scenario because of climate change impacts (as represented by the RCP water supply cost curves) minimally affect the results. As figure 7.56 shows, the effect on the total system cost is less than 0.1 percent. In addition, the changes are variable because of the varying nature of the RCP water supply cost curves. Furthermore, as figures 7.57 through 7.60 show, the water withdrawals, electricity generation (by type and by region), and the CO₂ emissions for these RCP scenarios are essentially identical.

Figure 7.57

Energy Sector Water Withdrawal and Change, by Type: All Policies Climate Change Cluster

Billion cubic meters

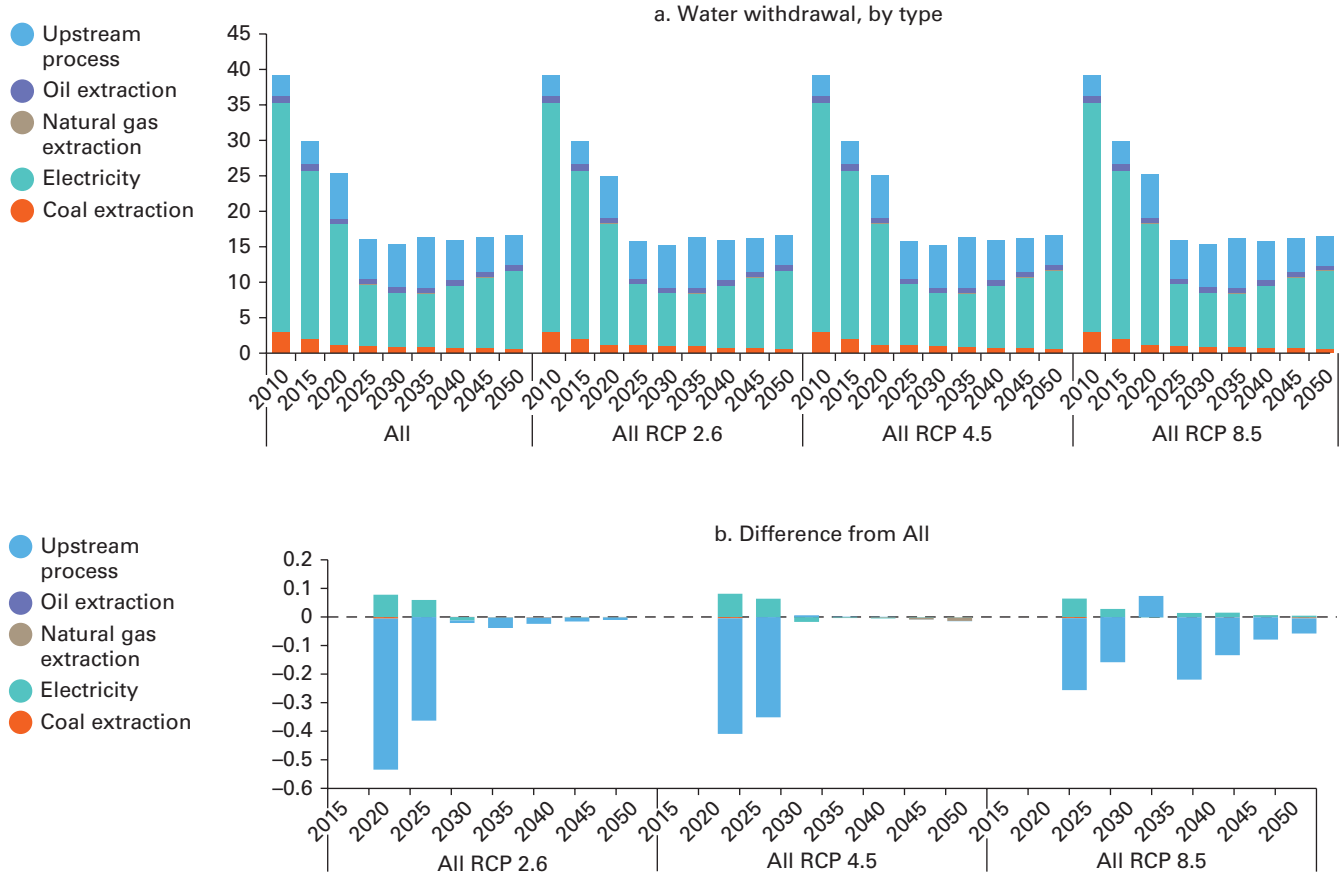

Note: RCP = representative concentration pathway.

Figure 7.58

Electricity Generation, by Fuel Type: All-Policies Climate Change Cluster
Terawatt-hours

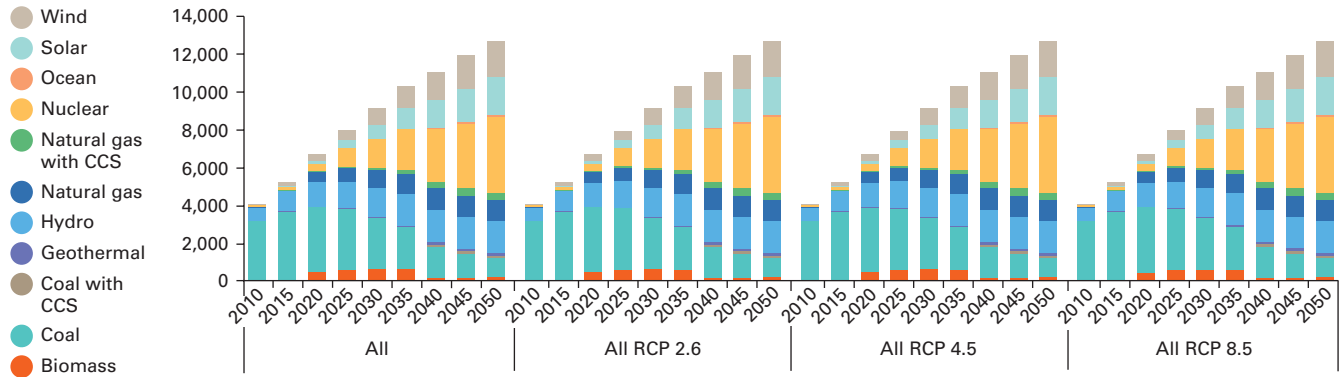

Note: CCS = carbon capture and storage; CHP = combined heat and power; CSP = concentrating solar power; PV = photovoltaic; RCP = representative concentration pathway.

Figure 7.59

Electricity Generation, by Region: All Policies Climate Change Cluster
Terawatt-hours

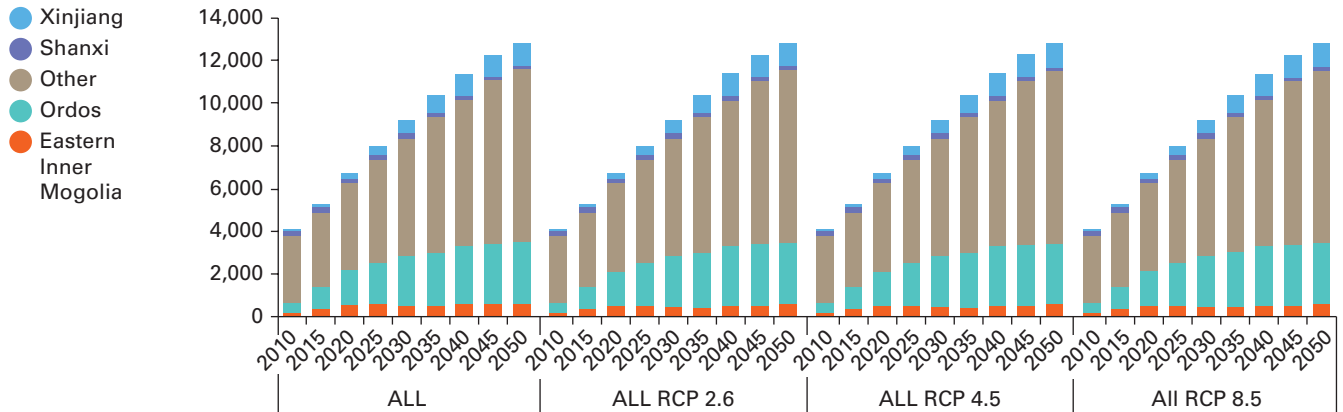

Note: RCP = representative concentration pathway.

Figure 7.60

CO₂ Emissions: All Policies Climate Change Cluster, 2010–50
Million metric tons

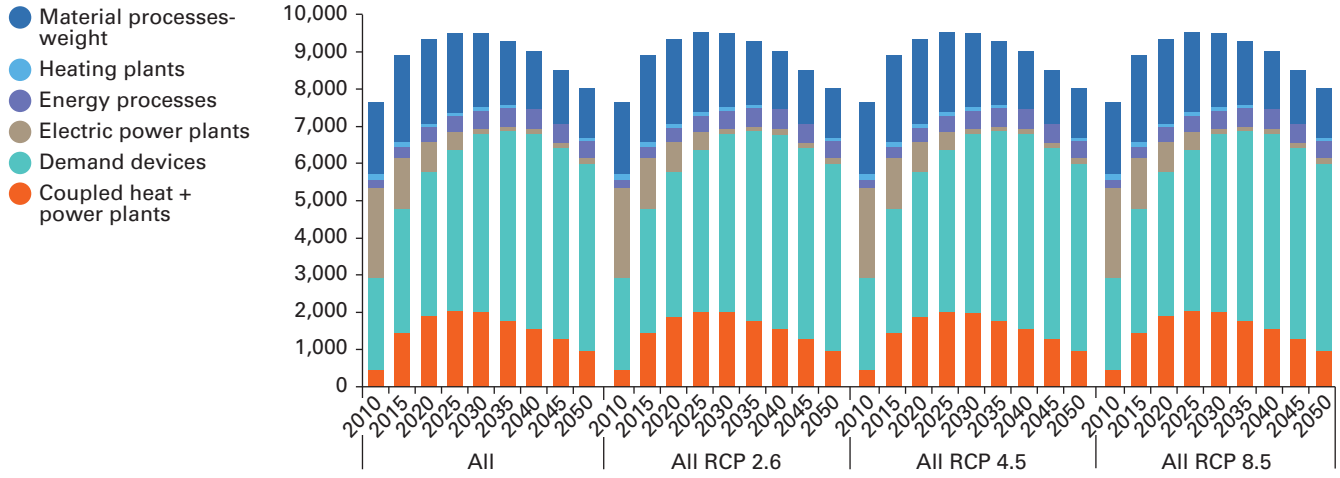

Note: CO₂ = carbon dioxide; RCP = representative concentration pathway.

08

**Methodology
Observations
and
Limitations
of the Initial
Analysis**

This analysis provides new information on and offers numerous important insights on the water-energy nexus in China; however, there are some limitations. Although they do not detract from the results obtained, the methodology could be improved as part of future integrated water-energy planning, perhaps in support of the preparation of the 14th Five-Year Plan.

- The approach used in the China case study is less robust than the approach used in the Thirsty Energy South Africa Case Study, where the water supply schemes were entered into the TIMES energy system model directly and the timing of the specific water supply options was determined within the water-energy framework rather than coming from the water model endogenously (World Bank 2016). For the China study, the energy model was given water supply cost curves for the energy sector, which imbedded all investment decisions in water infrastructure into the supply cost. As a result, the timing and payback requirement of the investment are not captured because of data unavailability.
- The China water supply cost curves include only water for the energy sector, instead of all-water demands, although they include the option for a limited amount of non-energy water supplies to be used for energy purposes by means of the transfer of agriculture water right.
- Given these last two points, future efforts to develop water-smart energy system planning model should internally derive the water supply cost curves on the basis of specific investment decisions on the regional demands of energy production, include the other sectors in the water demand, and provide options for shifting water allocations between various sectors.
- Basin-level water system planning models are used to provide data on the costs and availability of specific future bulk water supply and infrastructure options. However, this study is limited in that the aggregation to the energy base level may fail to capture local characteristics and complexities, especially regarding water delivery issues. The lack of complete regionalization of the energy sector demand for energy services limits the ability of the model to properly capture the complicated issues in China related to moving energy carrier versus electricity around the country.
- Although only one climate model (CNRM-CM5) was used to generate the hydrologic input to estimate water supply, the analysis includes climate change scenarios from less severe (RCP2.6) to very severe (RCP8.5) to capture a wide range of hydrologic responses in the Energy Bases to address the uncertainty in runoff and water supply estimates that are used in the integrated water-energy modeling. The runoff estimates produced by these simulations do not show a unidirectional trend. Runoff decreases in some locations and increase in others, a result that is consistent with most studies of climate change in China and in other parts of the world. However, uncertainty in regional climate projections and their effect on uncertainties in water resources availability should be explored with a broader set of climate models and assumptions. This is an active area of current research and one that definitely merits future work.

- Representing each of the main water consuming groups (agriculture, industry, urban, and energy) in the model, rather than tailoring the water supply cost curve to the current share of water for energy instead and assuming that the share of water for energy will remain about the same over time, would enable TIMES-ChinaW to exploring the effect of reallocation schemes associated with the water “red lines” on the energy sector. This would also enable the full water supply cost curve to be used in the model. A better option would be moving the water infrastructure supply and investment decisions inside the model (if the needed data can be developed).

09

Conclusion



© Land Rover Our Planet

The study results demonstrate key objectives of the Thirsty Energy initiative through the following important findings on the broader effects of modeling the water-energy nexus. This case study shows how a national-level energy systems model can be readily regionalized in its energy resource supply and power plant locations, and the regional costs and limitations for water supply infrastructure can be incorporated to create a water-smart planning tool.

Case Study Findings

This study also developed findings that are specific to the water-energy nexus in China. Perhaps the most significant findings are as follows.

- Properly including the cost of water supply, along with current policies aimed at requiring dry cooling for new coal plants in the Energy Bases, plans to close older smaller less efficient coal plants, the push to promote renewables and the commitment to achieves the goals stated in China's Nationally Determined Contribution (NDC), all embodied in the Reference scenario, combine to directly help the energy sector comply with important aspects of the water 3 Red Lines policies including the following:
 - Water withdrawal by the energy sector is lowered by 30 percent, from 29.83 billion m³ in 2015 to 20.96 billion m³ in 2030, contributing to meeting the target of the red line for total withdrawal control before 2030, with withdrawals

dropping further to 17.18 billion m³ in 2050 (42 percent) as a result of the adoption of solar PV and wind in the power sector and due to the coal chemical industry being cut back in upstream processes.

- For similar reasons, wastewater releases drop from 21.59 billion m³ in 2015 to 11.26 billion m³ in 2030 (48 percent), dropping further to 9.34 billion m³ in 2050 (57 percent) helping to address the water quality red line.
- Water consumption by the energy sector increases from 8.24 billion m³ in 2015 to 9.7 billion m³ (18 percent) by 2030 because of the substitution of backward once-through coal power plants by new ones using recirculating, later decreasing to 7.84 billion m³ (5 percent) in 2050 because of the substitution of coal power plant by Non-fossil generation that use less or no water.
- The intensity of water withdrawal for energy per unit of GDP moves from 8.42 m³ per thousand US dollars to 2.31 m³ per thousand US dollars, which is a relative index in line with the second red line of controlling the water withdrawal per unit of industrial added value.
- Moreover, this Reference scenario also shows a drop in CO₂ cumulative emissions of 125 gigatonnes compared to the Baseline Scenario without the CO₂ target.
- Incorporating the regional availability and costs of water supply infrastructure has a significant impact on the electricity generation cooling technology choice. Including the cost of water supply results in a shift similar to imposing the existing policy that restrict once-through cooling technology in the northwest region, reflecting the economic rationale for the policy.
- The impacts of climate change on the energy-water system were evaluated according to available medium- and long-term climate models results. These model results indicate that the Energy Bases become less water constrained under climate change, whereas the Other (wet) region will likely experience less rainfall—although not enough to dramatically affect the energy sector. Therefore, the impacts of climate change on the energy-water system evaluated were found to be minimal at an aggregated level. However, there might be localized impacts that are not captured in this aggregated model. For example, localized floods and droughts (on place and time) can affect the energy system.
- In general, this study has shown that current government policy in the energy sector is geared toward reducing water use, and that most of the policies being pursued to combat climate change both reduce CO₂ emissions and water needs—with modest increase in energy system cost.

These and the following results are primarily illustrative of some potential impacts that can be derived from more integrated energy-water planning and are not intended as a detailed policy study for China.

Effects of Water Costs on the Energy System Planning

Incorporating the cost of water significantly reduces power plant water withdrawals and provides an economic rationale for China's recent policy to prohibit once-through

cooling for power plants in the Energy Bases. Regionally, adding water cost into the modeling causes generation shifts by cooling type (away from once-through cooling systems) and by region (from the drier Energy Bases to the water-rich Other region). Adding the cost of water to most policy scenarios does not result in technology changes other than power plant cooling type.

Effect of Carbon Dioxide Policy on Water Use and Energy System

The Reference (CO₂ policies) scenario reduce water withdrawal compared with the Base scenario (no CO₂ constraint) because of the shift of power generation from traditional coal plants to Non-fossil sources that use less water. Electricity generation is shifted from coal to nuclear in the coast (using sea water for cooling) and to solar and wind in the Energy Bases. Once-through and recirculating power plant cooling types are phased out in the Other region as well in favor of air cooling, because of the combination of the CO₂ limit, the cost to get coal to the region and including the cost of water supply. Coal and oil are displaced from the final energy mix and are replaced by increased natural gas use and use of electricity from nuclear and renewables, along with energy efficiency improvements on the demand side.

The CO₂ policy reduces water use for energy, CO₂ emissions, as shown in table 7.5, and local air pollutants, as seen in figure 7.19, although it increases the total system cost. Note that the reduction of CO₂ emissions as required in the Reference and other scenarios (as per China's NDC), has an associated marginal cost of \$75/t CO₂ in 2020 and \$578/t CO₂ in 2050, so deeper cuts may prove to be quite challenging and costly.

Effect of Coal and Non-Fossil Fuel Policies on the Energy System

The Coal Peak policy is stricter than the other scenarios, and when added to the Reference scenario (CO₂ constraint), increases the total system cost by an additional 0.8 percent. The Coal Peak scenario has higher costs because it forces earlier investments into constructing nuclear and renewable power plants, and decommissioning coal power plants that are kept operating longer in the Reference scenario.

The Non-fossil policy provides flexibilities in the timing and types of Non-fossil plants that are built, and reduces the total system cost slightly (0.06 percent) compared with the current plans. This plan accelerates the timing and provides greater regional distribution to the Non-fossil power plant deployments.

The Coal chemical policy has only modest implications for the energy system and minimally reduces greenhouse gas emissions. When combined with the CO₂ policy (Reference scenario), there is little improvement given that most changes are driven by the CO₂ policy in the Reference scenario. Including the cost of water

supply reduces water usage in the coal chemicals scenario given that the chemicals industry is neither limited by the power sector’s restriction on once-through cooling nor affected by the power sector changes that result from the CO₂ or Coal Peak policies.

Regionally, these policies (except the Coal chemical policy) tend to shift power generation from Shanxi (because of the reduced coal use) to the Other region and Ordos.

Effect of All Polices on Water Withdrawals and Energy System

The All-policies scenario reduces water withdrawals by the energy sector because of the earlier investments into nuclear and renewable power plant builds (see table 9.1). The increased electricity generation from nuclear, natural gas, and renewables reduces CO₂ emissions by an additional 12.5 billion tons cumulatively through 2050 compared with the Reference scenario because of the earlier actions generated by the Coal Peak policy. However, the increased investment in nuclear, gas and renewable plants increases the price of electricity in the latter periods (after 2040), which then results in some fuel switching in the demand sectors away from electricity to natural gas and offsets some of the emission reductions from the power sector.

The impact in terms of the energy sector meeting the water 3 Red Lines policies arising from the all-policies scenario include the following:

- Water withdrawal by the energy sector is lowered by 49 percent in 2030, from 29.83 billion m³ in 2015 to 15.25 billion m³, contributing to meeting the target of the red line for total withdrawal control before 2030, with withdrawals remaining low at 16.59 billion m³ in 2050 (44 percent) as a result of the adoption of solar PV and wind

Table 9.1 Water Savings, Carbon Dioxide Reductions, and System Cost Impacts

Scenario	Water savings (billion m ³)	CO ₂ reductions (metric tons)	System cost change (million dollars)
Base	0	0	0
Reference	108.3	124,777	828,230
Coal Peak with CO ₂	166.8	137,881	1,088,544
All	200.2	137,845	1,233,201

Note: CO₂ = carbon dioxide.

in the power sector and due to the coal chemical industry being cut back in upstream processes.

- For similar reasons, waste water releases drop from 21.59 billion m³ in 2015 to 6.6 billion m³ in 2030 (69 percent), although then raising slightly to 9.15 billion m³ in 2050 (still a reduction of 58 percent from current levels) helping to address the water quality red line.
- Water consumption by the energy sector increases from 8.24 billion m³ in 2015 to 8.65 billion m³ (5 percent) in 2030 because of the substitution of backward coal once-through power plants by new ones using recirculating cooling, later decreasing to 7.41 billion m³ (10 percent) in 2050 because of the substitution of coal power plant by Non-fossil generation that require less or no water.
- The intensity of water withdrawal for energy per unit of GDP moves from 8.42 m³ per thousand US dollars to 2.31 m³ per thousand US dollars, which is a relative index in line with the red line for controlling the water withdrawal per unit of industrial added value.

Effect of Climate Change on Water Withdrawals and Energy System

The differences in water supply and cost between the representative concentration pathways (RCP) scenarios (RCP2.6, RCP4.5, and RCP8.5) are not enough to show any significant effects to the energy system evolution. The climate models used to estimate the impacts of climate change on water supply in China indicate that the water-thirsty Energy Bases will actually receive more rainfall (although with greater variation), while the water-rich Other region will experience marginally less water but not enough to influence the results. The RCP scenarios have a negligible effect on system cost. Water use shifts are small with most reductions in Eastern Inner Mongolia, and most additions in the Other region. Compared with the effects of the key policies, the influence of climate change impacts on the water supply curves causes only small changes in the energy system.

Next Steps

The development of the TIMES-ChinaW model, and this Thirsty Energy study providing initial results, are an important step toward an integrated approach to water-energy planning in China. Several different policy regimes were examined, and some limited sensitivity analysis performed. Although this case study captures the primary uncertainties that are considered sufficiently for a proof of concept, there are both institutional and technical follow-on activities that have been identified to improve the quality of the tools for future assessment and decision support of the water-energy nexus in China. In this regard, the following technical areas for additional work were identified to improve various aspects of the model and further expand the coverage and insights that can be obtained.

- Incorporating the investment costs, supply amounts, and potential timing of specific regional water supply schemes into TIMES-ChinaW to allow the model to determine the timing of the investments in water infrastructure and thereby a more representative marginal water supply cost in each region in accordance with the specific scenario constraints.
- Harmonizing growth assumptions driving non-energy water demands and energy demands, which currently come from two different modeling frameworks (TIMES-ChinaW and water use models) that are only broadly internally consistent.
- Further disaggregating the depiction of the energy bases to move toward a more accurate depiction of the energy supply picture for the country and developing a clearer tie with the local water supply infrastructure challenges and options.
- Taking a closer look at the water policy aspect of the water-energy nexus, and the inherent tradeoffs that water allocation schemes need to address. It is highly desirable to incorporate a more detailed representation of non-energy water consumption (and policies) into TIMES-ChinaW to examine water reallocation schemes, demand elasticity to cost, and the effect of water-use efficiency and demand side management (DSM) interventions.
- Building on the previous point, developing water linkages to a variety of biofuel feed stocks and other aspects of land use and food production in terms of both water and energy.
- Developing a linkage with an economic model to assess the impact of the water-energy nexus tradeoffs on the economy as a whole including the effects on employment, GDP, and affordability.
- Conducting more sensitivity analysis to address uncertainty concerns with respect to water project costs and availability expectations, as well as non-energy water demand, particularly under climate change; using more than one climate model.
- Conducting more sensitivity analysis around key assumptions in TIMES-ChinaW as it relates to the energy sector (for example, resource levels, technology costs/potential, demand for energy services, aspects of the 13th Five-Year Plan goals) to demonstrate the robustness of the model results.
- Including the water needs for hydropower. In this study, the water needs for hydropower in the Other region were not explicitly modeled in TIMES-ChinaW (given that their water needs were excluded in the Institute for Water and Hydro Resources water supply cost curves).
- Researching the localized impacts of plant location (that is, getting water from sources to site needed), and intra-annual variations of the water-energy nexus, especially under climate change, such as floods and droughts, and how can they affect the energy system in China.
- Analyzing thermal pollution of once through cooling systems and its impact on the ecosystem.

- Ensuring that the study conclusions and main insights are included and used in other World Bank initiatives in the country, such as the ongoing China Water Governance study.
- Improving the conclusions regarding climate change impacts on the energy sector. This study was not intended to address in detail the issue of climate change in the areas of study but rather illustrate the potential impact of climate change on the water-energy nexus projections, particularly on water supply and availability. This was done by exploring several climate change scenarios through a representative climate model for China. Uncertainty in regional climate projections and their effect on uncertainties in water resources availability should be explored with a broader set of climate models and assumptions and using more detailed studies that focus specifically on regional climate change effects in the region. This is an active area of current research and one that definitely merits future work.

In addition to the technical issues mentioned above, effort is needed to develop closer institutional ties with the key planning institutions in China concerned with water (MWR), energy (NEA) and climate change (Department of Climate Change of the National Development and Reform Commission). Moreover, unavailability of certain data limited the ability to represent the water infrastructure and regionalize the energy demand in TIMES-China would enable critical aspects of the method to be further advanced. Further development of the model would position TIMES-ChinaW to contribute even most substantially to the critical analysis of water-energy nexus issues as part of the next 5-Year Plan process—by providing a comprehensive platform to examine policy, development, climate, and sustainability tradeoffs.

This study demonstrates that important insights can be gained by linking water and energy planning models. This can help properly assess integrated water-energy strategies and ensure that these critical long-term aspects of sustainable development are intelligently planned in a least-cost manner. This is particularly important as countries prepare to determine how to realize their nationally determined contribution commitments in a way that contributes directly to achieving the Sustainable Development Goals. This report aims to continue the process of informing decision makers that such a comprehensive, integrated approach provides for better informed policy formulation and planning processes and needs to become the norm.

Appendix A

Water Model

Model Description

The Coupled Land Surface and Hydrology Model System (CLHMS) is an advanced framework for examining the nature of China's future water supply picture (Yu, Pollard, and Cheng 2006). It includes a large-scale land surface model and a fine grid distributed hydrological model (Pollard and Thompson 1995; Yu and others 1999). The coupling between the land surface model and hydrological model is based on predicted soil moisture and surface water depth. The land-surface models include a two-layer vegetation model, a three-layer snow model, and a six-layer soil model; the hydrological models include a terrestrial hydrologic model (THM), a groundwater hydrologic model (GHM), and a channel ground-water interaction (CGI).

The parameters in the CLHMS include soil texture, vegetation type, hydrological parameters, and hydrogeological parameters. Soil texture is interpolated with the global dataset of Global Environmental and Ecological Simulation of Interactive System, and vegetation type uses CLDH data (China Land-use Data for Hundred years) (Thompson and Pollard 1995; Feng and others 2014). Hydrologic parameters in the basin are developed from the HYDRO1k Digital Elevation Model provided by USGS (United States Geological Survey) with ZongBo algorithm (Yang and others 2007). The hydrogeological parameters such as hydraulic conductivity and porosity are interpolated with the Harmonized World Soil Database (Fischer and others 2008). The CLHMS replicates well the natural hydrological processes, the simulation of the water balance, and the seasonal and inter-annual variation of stream flow. It has been verified against historical data for the Yellow River Basin, the Huaihe River Basin, the Song-Liao River Basin, and the Pearl River Basin in China (Yang and others 2011; Zhu 2015; Zhu, Lin, and Hao 2015). An overall depiction of the Coupled Land Surface and Hydrology Model System framework and interaction of the modules is shown in figure A.1.

Assumptions

To analyze the future water resource variation in the Energy Bases, first an extrapolation of recent trends was done to establish the business as usual (base) representation for China future water supply. The Coupled Model Intercomparison Project (CMIP) representative concentration pathways (RCPs) are then used as the atmospheric driver of CLHMS simulation of the response of water cycle under different possible scenarios.

In consideration of the global climate model's (GCM) simulation ability, first the temperature and precipitation simulation capabilities during the 20th century (1962–2005) of 14 global climate models in China are examined (Zhu 2015). CNRM-CM5, HadCM3, and IPSL-CM5A-LR show a better simulation capability in China. The spatial resolution of CNRM-CM5 (256×128) is higher than HadCM3 (96×73) and IPSL-CM5A-LR (96×96). The CNRM-CM5 shows a better simulation capability in China, especially in the Yellow River Basin and in northeast China.

Figure A.1

The Framework of Climate Land Surface and Hydrology Model System

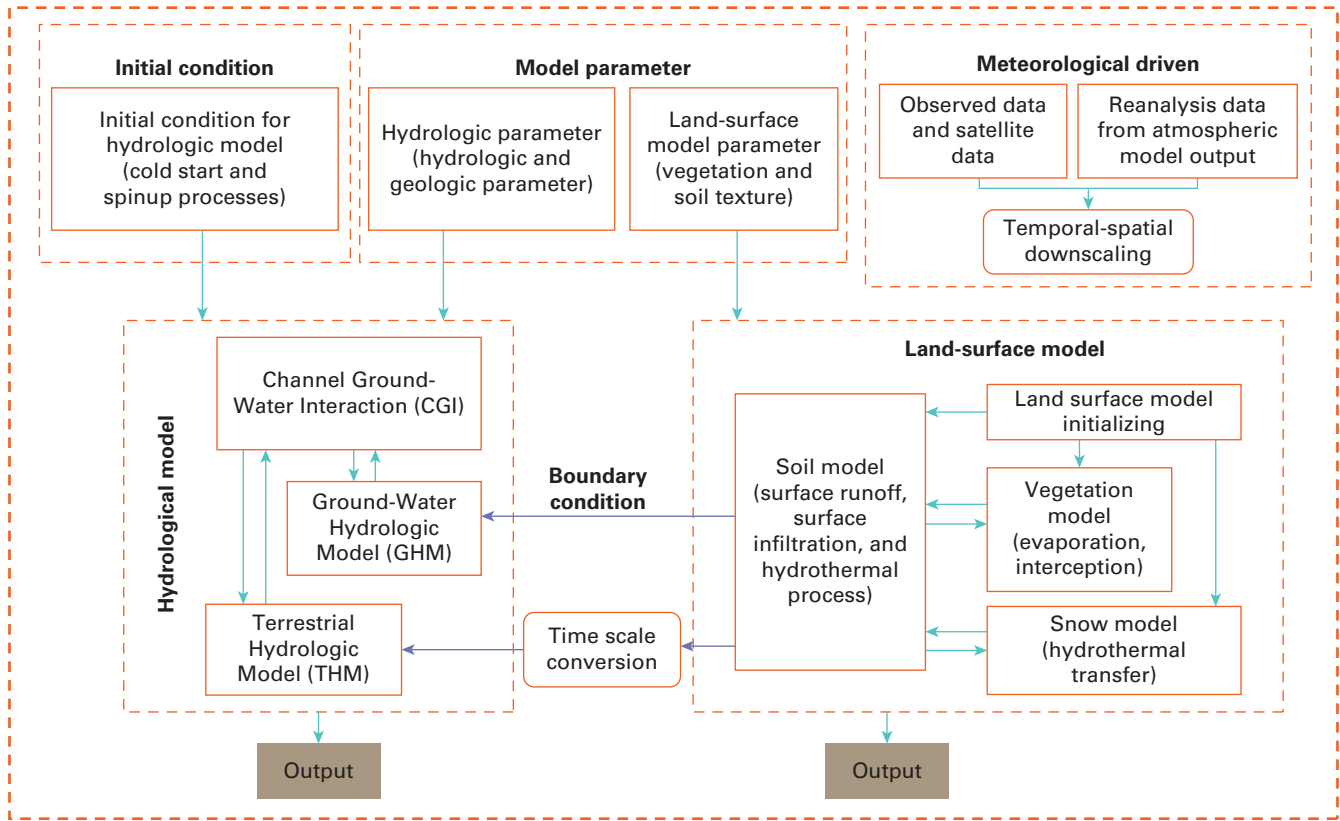

Phase 5 of the CMIP (CMIP5) experiments include the historical climate simulation experiments for the 20th century and prediction experiments for the 21st century driven by RCP concentrations. On the basis of the East Asia gauge-based analysis of daily precipitation data, daily temperature CN05 and the historical run's outputs of 14 CMIP5 global climate models, the characteristics of precipitation and temperature is investigated (Xie et.al. 2007; Xu 2009). The historical experiment of CMIP5 uses the result of experiment result before the Industrial Revolution (PiHistorical run) as the initial field for integrating, all of the observed data were used and varied from time changes as the force field, such as greenhouse gas, ozone, aerosol, volcanic activity, and solar constant. The simulation period is from 1850 to 2005, and the simulation result indicates the correspondence relation between the recurring of historical climate and actual calendar. Therefore, it can be compared with the observational data to estimate the simulation capability of the climate system model. In addition, table A.1 lists all of the data required by the hydrological model and the corresponding data available in CNRM-CM5, which is a pretty good fit.

Table A.1**CLHMS Required Variables and Corresponding Variables in CNRM-CM5**

No.	Variable in CLHMS	Unit	Variable description in CNRM-CM5
1	Precipitation	Kg/m ² /s	Precipitation
2	Air temperature 2 m	K	Near-surface air temperature
3	Eastward wind	m/s	Eastward near-surface wind
4	Northward wind	m/s	Northward near-surface wind
5	Specific humidity	Kg/kg	Near-surface specific humidity
6	Surface pressure	Pa(N/m ²)	Sea-level pressure
7	Total cloud	%	Total cloud fraction
8	Downward longwave radiation flux	W/m ²	Surface downwelling longwave radiation
9	Near Infrared beam downward solar flux	W/m ²	Surface downwelling shortwave radiation
10	Near Infrared diffuse downward solar flux	W/m ²	
11	Visible beam downward solar flux	W/m ²	
12	Visible diffuse downward solar flux	W/m ²	

Note: CLMHS = Coupled Land Surface and Hydrology Model System; CNRM-CM5 = Centre National de Recherches Météorologiques-Coupled Models, version 5.

The CNRM-CM5 model, developed by CNRM-GAME (Centre National de Recherches Météorologiques—Groupe d' études de l'Atmosphère Météorologique/France National Centre for Meteorological Research—Meteorological and Atmospheric Studies Group) and CERFACS (Centre Européen de Recherche et de Formation Avancée/European Centre for Research and Advanced Training), was selected for this study (Voldoire and others 2013). It contains an atmospheric model ARPEGE-Climate v5.2 (Action de Recherche Petite Echelle Grande Echelle/Research Project on Small and Large Scales), a land surface model SURFEX/TRIP (Surface Externalisée/Total Runoff Integrating Pathways), an ocean model NEMO v3.2 (Nucleus for European Modelling of the Ocean), a sea ice model GELATO v5 (Global Experimental Leads and Ice for Atmosphere and Ocean) and OASIS v3 coupler with 1.4° atmospheric model resolution, 31 layers in vertical direction, and 1° ocean model resolution.

Daily precipitation, near-surface air temperature, eastward near-surface wind, northward near-surface wind, near-surface specific humidity, sea-level pressure, total cloud fraction, surface down welling longwave radiation, and surface downwelling shortwave radiation data from three RCP scenarios of CNRM-CM5 was used as the meteorological data for CLHMS model. To reduce the systematic error in the global climate model's simulation result, the RCPs output from the global climate model needs to be corrected for biases. Therefore, a statistical bias correction is applied to daily precipitation and daily temperature with the observed East Asia (EA) precipitation data and CN05 temperature data.

In terms of climate change impacts, first setting spatial characteristics for climatic factors in benchmark phase was done to correct the models' climatic estimate results. Then the corrected estimated results of precipitation are applied to further analyze the trend of climate change under three different emission concentration path scenarios. To this end, climate change may increase frequency and intensity of extreme disasters such as flood and drought, as well as exert a direct effect on rainfall, evaporation, runoff, and soil moisture. By applying IPCC-AR5's (Fifth Assessment Report of Intergovernmental Panel on Climate Change) high resolution model of CNRM-CM5, climatic estimates of the 21st century are made in low, moderate, and high emission concentration path scenarios (corresponding to RCP2.5, RCP4.5, and RCP8.5, respectively). With CLHMS model, water cycle changes in the study areas (Energy Bases) under future climate change scenarios are estimated as subsequently discussed.

Analytical Method for Water Supply in Energy Bases

Water supply analysis in the main Energy Bases is achieved mainly by data collection and investigation. The water supply projects constructed or under construction from 2015 to 2020 have been analyzed according to the 12th and 13th Five-Year Plan. The future forecast of water supply and utilization for research regions is based on water resources comprehensive planning (National Development and Reform Commission, Ministry of Water Resources, and National Comprehensive Water Resources Planning 2010).

Water supply projects in this study are divided into major categories of impoundment and diversion projects, external water transfer projects, and unconventional water use projects on the basis of current construction of water conservancy projects. By investigating typical projects and collecting water price and current water supply projects costs, a set of statistical parameters regarding large-scale water supply project of different types were compiled and analyzed. Small-scale projects are classified by type and water supply costs analyzed according to current projects of similar type.

For the future water supply analysis in the Energy Bases against the backdrop of climate change, water resources changes within a river basin were studied by applying the CLHMS model combined with CMIP5 typical concentration paths, RCPs. The CLHMS model is suitable for the whole country, and the low, medium, and high benchmarks for greenhouse gas emissions, corresponding to RCP2.6, RCP4.5, and RCP8.5, respectively, were selected as possible future climate change scenarios. The resulting future water resources changes in the Yellow River Basin, the Haihe River Basin, and the Songliao River Basin were simulated; and the Energy Bases within the river basin were matched spatially to obtain the changes in water resources quantity against the background of climate change.

On the basis of field surveys and investigations, the status of the current water supply and future water needs was determined, and water project schemes were

identified for the four major Energy Bases. As previously noted, the cost of different water projects was determined by type (for example, local surface water project, diverted water source project, and recycled water utilization project). The supply costs of typical major water projects in each Energy Base were calculated on the basis of project fixed investment, depreciation cost, operation and maintenance costs, water fee, and external costs (for example, sewage treatment fees). Small-scale water supply projects estimates of the project and water supply cost were considered as a group. For projects that have been recently completed, on-site investigation has been undertaken to determine the cost. For projects under construction and planned, a comparative analysis for similar water supply project was undertaken to determine their cost.

A fixed assets depreciation is calculated according to the life of the project, which is used to replace equipment losses. The annual operating and management cost includes fuel and power cost, variable operating and repair expense, and fixed management fee, salary, welfare benefits, allowance, and compensation and other necessary expenses.

According to “The Regulation for Economic Evaluation of Water Conservancy Construction Projects” published by the Ministry of Water Resources, the normal operation period for water supply projects is 30–50 years, 40–50 years for large or medium-sized hydropower station/dam, and 15–25 years for small hydropower station or drainage station.

Because of the scarcity of water resources and the expense incurred in the process of management and protection of water resources an externality cost is charged for the users of water resources. This external cost is used to compensate the negative effects of water resource use on the ecological environment.

To this end, the unit water supply cost (UWSC) calculation is as follows:

$$P_{water} = \frac{Z_1 + Z_2 + Z_3 + Z_4}{W}$$

where:

P_{water} is the water supply cost,

Z_1 is the depreciation of fixed assets,

Z_2 is repair maintenance fee,

Z_3 is annual operation and management fee,

Z_4 is water resources fee and external costs, and

W is the annual average water supply.

In terms of climate change, it affects precipitation, which affects regional water resources quantity, and thereby can affect projects water supply capacity. Therefore, climate change produces an indirect effect on the project cost of water supply, such that when precipitation increases, project water supply capacity must increase correspondingly, which indirectly reduces the water cost to the energy industry, making

water resources constraints become less severe; and when precipitation decreases, project water supply capacity drops, thus increasing the water resource constraints leading to higher cost for new water supply.

Quantitative analysis of projects was based on their water supply, construction, and operation costs, resulting in changes in the cost of water supply. An overview of the methodology is shown in figure A.2.

Figure A.2 Method for the Water Supply Cost Curve Calculation

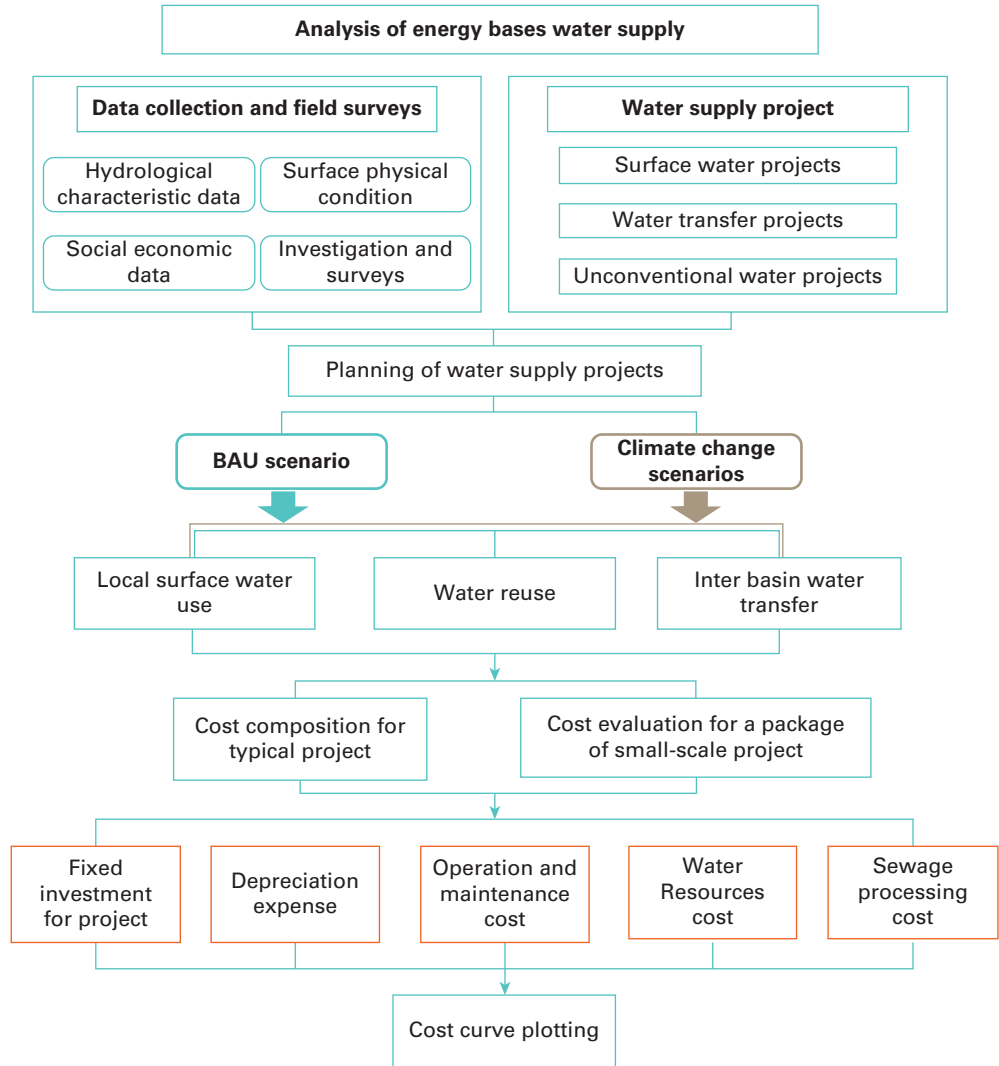

Note: BAU = business as usual.

Analytical Method of Temporal-Spatial Changing of Water Resources Quantity in Energy Bases

The basins and regions where China's major Energy Bases are located are markedly different. These Energy Bases have huge differences in water resources distribution characteristics, and they have to be analyzed independently.

Shanxi Energy Base

The Shanxi Energy Base is mainly located in the Yellow River basin and a small part of the energy base is located in the Hai River basin. Therefore, the majority of the available water resources of the Shanxi Energy Base are from the Yellow River Basin. Because the trunk stream of the Yellow River flows through the Shanxi Energy Base, the total available water resources in the Shanxi Energy Base include the two parts: the local water resources generated from the precipitation and the water diverted from the trunk stream of the Yellow River. According to the 87 Water Allocation Scheme, the upper limit of the water volume diverted from Yellow River Basin for the Shanxi Energy Base is 4.31 billion m³ per year. On the basis of this analysis, the water resources quantity available for the energy industry in the Shanxi Energy Base can be calculated by the following formula:

$$Y_1 = \alpha \times [f(x)_1 + f(x)_2]$$

where,

Y_1 is the water resources quantity available for the energy industry in the Shanxi Energy Base,

$f(x)_1$ is the local available water resources in the Shanxi Energy Base,

$f(x)_2$ is the available water diverted from the trunk stream of Yellow River, and

α is the coefficient, which is the ratio between the water resources quantity consumed for the energy industry and the total water resources available in the Shanxi Energy Base.

In this research, $f(x)_1$ and $f(x)_2$ can be calculated through hydrological modeling using the CLHMS model, and the coefficient α is determined based on the statistical and survey data in the recent more than 10 years.

Ordos Energy Base

The Ordos Energy Base, stretching across Shaanxi, Inner Mongolia, Gansu, and Ningxia, has complicated river systems, some of which belong to the Yellow River

Basin and the other belong to the Northwest Inland Basin. Therefore, the total available water resources in the Ordos Energy Base also include two parts, one is the volume of the available water resources of the river system in the Yellow River Basin, and the other one is the volume of the available water resources of the river system in the Northwest Inland Basin. On the basis of the aforementioned analysis, the water resources quantity available for the energy industry in the Ordos Energy Base can be calculated using the following formula:

$$Y_2 = \alpha \times f(x)_1 + \beta \times f(x)_2$$

where,

Y_2 is water resources quantity available for the energy industry in Ordos Energy Base,

α is the ratio between the water resources consumed for the energy industry and the total water resources available in a part of Ordos Energy Base of the Yellow River Basin;

$f(x)_1$ is the Yellow River Basin water resources quantity of Ordos Energy Base in Yellow River Basin,

β is the ratio between the water resources consumed for the energy industry and the total water resources available in a part of Ordos Energy Base of the Northwest Inland Basin, and

$f(x)_2$ is the water resources quantity of Ordos Energy Base in the Inland River Basin.

In this research, α and β are both determined by statistical and survey data.

Eastern Inner Mongolia Energy Base

The Eastern Inner Mongolia Energy Base, located in the east of Inner Mongolia, consists of Hulun Buir, Chifeng, Tongliao, and Hinggan League. It belongs to the Haihe River Basin, the Northwest Inland River Basin, and the Song-Liao River Basin. The water resources quantity available for the energy industry in the Eastern Inner Mongolia Energy Base can be calculated using the following formula:

$$Y_3 = \beta \times f(x)_1 + \varepsilon \times f(x)_2 + \delta \times f(x)_3$$

where,

Y_3 is water resources quantity available for the energy industry in the Eastern Inner Mongolia Energy Base,

β is the the ratio between the water resources consumed for the energy industry and the total water resources available in Haihe River Basin of Eastern Inner Mongolia Energy Base,

ε is the the ratio between the water resources consumed for the energy industry and the total water resources available in the Northwest Inland River Basin of Eastern Inner Mongolia Energy Base

δ is the the ratio between the water resources consumed for the energy industry and the total water resources available in Song-Liao River basin of the Eastern Inner Mongolia Energy Base;

$f(x)_1$, $f(x)_2$, and $f(x)_3$ are the total available water resources, respectively, in the Haihe River Basin, the Northwest Inland River Basin, and the Song-Liao River Basin of the Eastern Inner Mongolia Energy Base, which can be simulated through the hydrological model. Similarly, β , ε , and δ are all determined by statistical and survey data.

Xinjiang Energy Base

The Xinjiang Energy Base is located in the Northwest Inland River Basin, where, the glaciers are an important replenishment source of water resources. The relation between water for energy and overall water resources is represented by the following formula:

$$Y_4 = \beta \times f(x)_2 + G$$

where,

Y_4 is water resources quantity of Xinjiang Energy Base,

β is the ratio between the water resources consumed for the energy industry and the total water resources available in the Xinjiang Energy Base,

$f(x)_2$ is total water resources in the Inland River Basin of the Xinjiang Energy Base, and

G is the glaciers replenishment quantity.

In this research, β can be determined by the survey method, and $f(x)_2$ can be simulated by hydrological model, and G is estimated by the empirical formula.

Regional Water Resources Quantity under Climate Change Scenario

Driven by the impacts of global warming, land water form changes affect the entire water cycle process and the temporal-spatial distribution of water resources. By applying IPCC-AR5's high-resolution model of CNRM-CM5, climatic estimates of the 21st century are made in low, moderate, and high-emission concentration path scenarios (RCP2.6, RCP4.5, and RCP8.5). With the CLHMS model, water cycle changes in the study area under future climate change scenarios are estimated as shown for each basin in figure A.3.

Although only one climate model (CNRM-CM5) was used to generate the hydrologic input to estimate water supply, the analysis includes climate change scenarios from less severe (RCP2.6) to very severe (RCP8.5) to capture a wide range of hydrologic responses in the Energy Bases to address the uncertainty in runoff and water supply estimates that are used in the integrated water-energy modeling. The runoff estimates

produced by these simulations do not show a unidirectional trend—that is, runoff is found to decrease in some locations and increasing in others, a result that is consistent with most detailed studies of climate change in China and other parts of the world.

It is worth noting that this study was not intended to address in detail the issue of climate change in the areas of study, but rather illustrate the potential impacts of climate change on the water-energy nexus projections, particularly on water supply and availability. This was done by exploring several climate change scenarios through a representative climate model for China. Uncertainty in regional climate projections and their effect on uncertainties in water resources availability should be explored with a broader set of climate models and assumptions and should be explored in more detailed studies that focus specifically on regional climate change impacts in the region. This is an active area of current research and one that definitely merits future work.

Figure A.3

RCP Water Supply Curves for Major Basins, 2010–50

Billion cubic meters

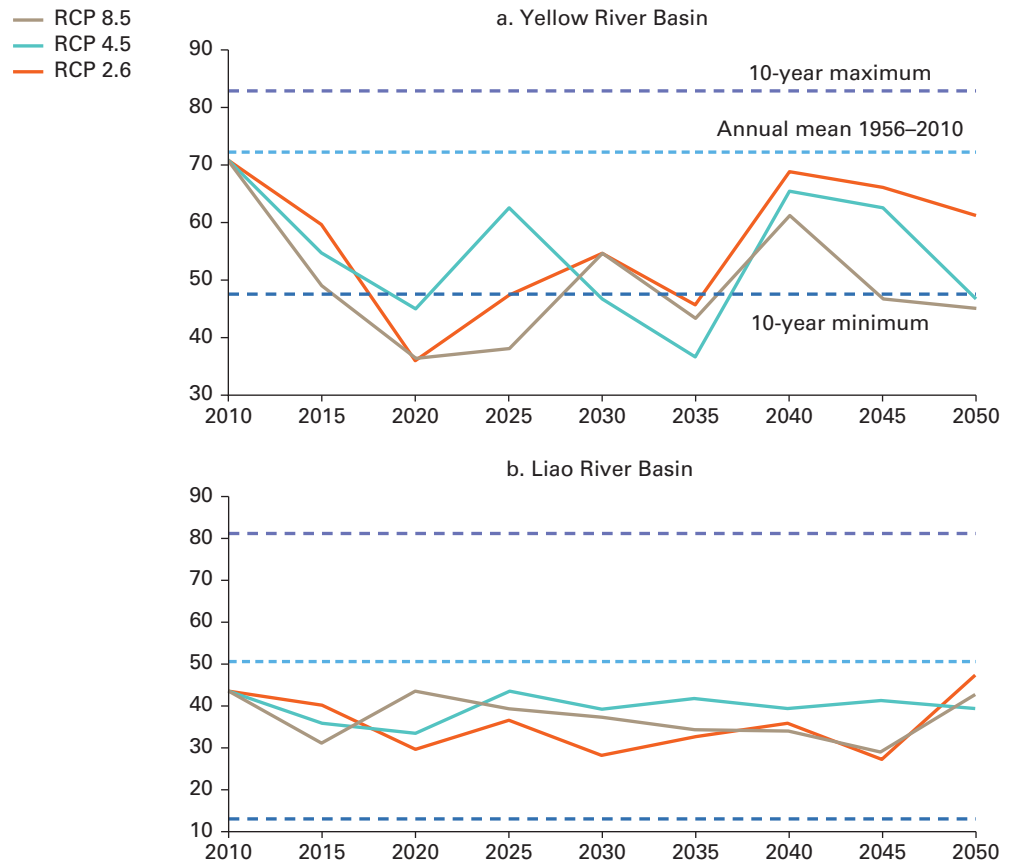

(continued)

Figure A.3

RCP Water Supply Curves for Major Basins, 2010–50 (continued)



Note: RCP = representative concentration pathway.

Appendix B

Energy Model

Model Description

TIMES (The Integrated MARKAL and EFOM Model) is a bottom-up model developed within the Energy Technology System Analysis Program of the International Energy Agency. TIMES is an economic model generator for local, national, or multiregional energy systems, which can provide a technology-rich basis for estimating energy dynamics over a long-term, multiperiod time horizon. The TIMES-China model, the starting point for the TIMES-ChinaW model, was developed by Tsinghua University. For the Base scenario estimates were made of the existing stock of energy-related equipment and available future technologies, potential of primary energy supply as well as end-use energy service demand of China. TIMES-China incorporates the full range of energy processes including extraction (and imports), conversion, transmission, distribution, and end use, as shown in figure B.1. More than 400 technologies are included in the model, consisting of existing and advanced technologies such as poly-generation technologies with carbon capture and storage, and emission flows are tracked by fuel and sector. TIMES-China is widely used to study the future evolution of the national energy system and associated CO₂ emissions. In this study, water was incorporated into the TIMES-China model to realize the TIMES-ChinaW model, which uses 5-year intervals from 2010 to 2050. The objective function of the model minimizes total energy system cost, including capital costs, fuel costs, and operating and maintenance costs for technologies both in energy supply and demand side while meeting final energy service demands and external constraints.

The optimization is driven by the demand for energy services, which are estimated by end-use applications for every sector. Five demand sectors, agriculture, industry, commercial building, residential building (divided into urban and rural) and transportation, are considered and further divided into 43 subsectors as shown in figure B.2. High energy consumption industries such as iron and steel, cement, pulp and paper, glass, along with captive power electricity and heat are included in the industry sector, as shown in figure B.3. Transportation is divided into passenger transport and freight transport, along with aviation, railway, road, and pipelines. Residential sector includes rural and urban buildings and services such as heating, cooling, lighting, refrigeration, clothes washing, and other appliances are specifically considered. The commercial sector includes services for heating, cooling, lighting, and appliances. An overview of the structure of the demand sectors is shown in figure B.2.

To project energy service demands requires future social and economic development to be estimated. GDP growth, industrial structural changes, population, urbanization rate and other social and economic trends are estimated with different projection methods applied for the various sectors and industries. The projection method for iron and steel is shown in figure B.3.

Times-ChinaW represents industrial processes in a very detailed way. Take iron and steel industry, for example, as shown in figure B.4. The model considers seven processes: coke making, sintering/pelleting, blast furnace, oxygen blown converter, electric arc furnace, casting, and rolling. Because the energy intensity of other industries is much lower than those of the key iron and steel and cement industries in China, they are also considered but not at this fine a level of detail.

Figure B.1 Simplified RES of TIMES-ChinaW

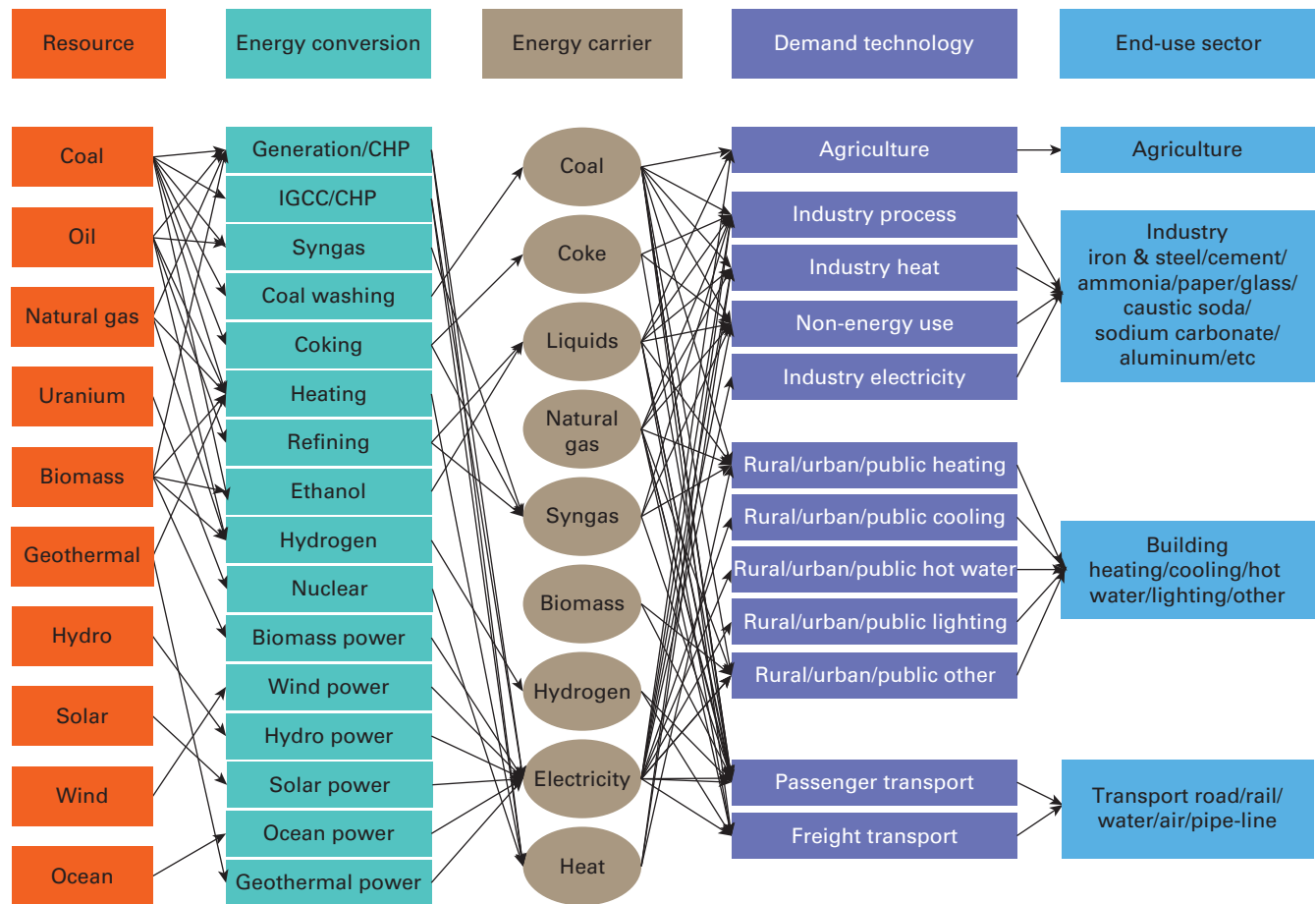

Note: CBM = coal bed methane; CHP = combined heat and power.

China has five integrated Energy Bases: Xinjiang, Ordos, Shanxi, East Inner Mongolia and Yungui, which are mostly consistent with the fourteen coal bases. As Yungui is rich in water resources, this research will focus on the other four integrated Energy Bases. In consideration of data availability, this research uses the provincial data as an approximation. Xinjiang Energy Base is approximated by Xinjiang Province. Shanxi Energy Base is approximated by Shanxi Province. East Inner Mongolia is approximated by the east part of Inner Mongolia, which contains four cities: Hulun Buir League, Hinggan League, Tongliao League and Chifeng League. East Inner Mongolia accounts for 56.2 percent of the area and 52.9 percent population of Inner Mongolia. Ordos Energy Base is approximated by the aggregation of Shaanxi, Ningxia, Gansu and Western part of Inner Mongolia. The regional representation and the water representation in the model are shown in chapter 6.

Figure B.2

Simplified Representation of Demand Sectors in TIMES-ChinaW

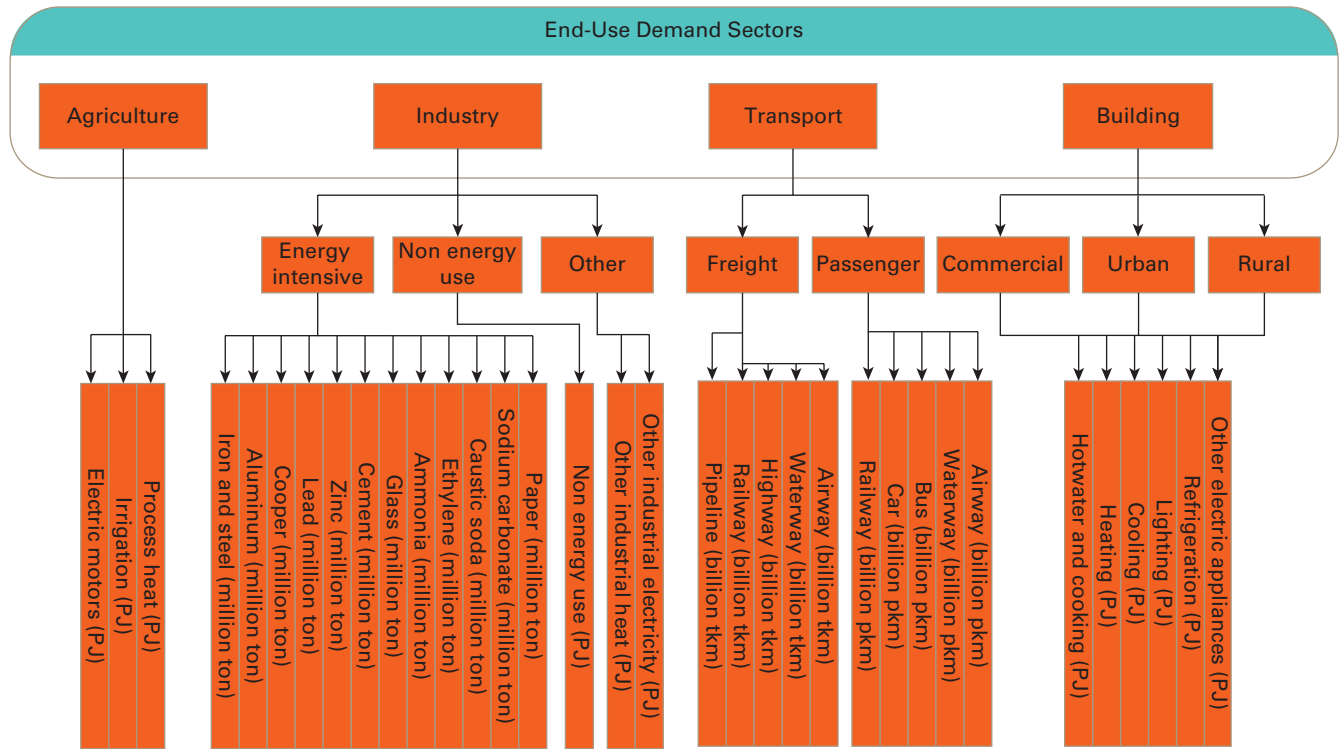

Note: PJ = petajoules; pkm = person kilometer; tkm = ton kilometer.

Assumptions

As discussed in the previous section, basic economic and demographic driver assumptions underlying the base scenario include population growth, urbanization rate, economic development, and industrial structure that underpin the estimates of the energy service demands for the different sectors. These directly influence the future energy supply requirements and thereby emissions.

Economic growth is the main factor driving energy consumption. Over the past three decades, China's economy has experienced rapid development, with an annual growth rate of approximately 10 percent. On the basis of the analysis of China's economic development trends, the average annual GDP growth rate is assumed to be

Figure B.3

Projection Method for Energy Service Demand in Iron and Steel Sector

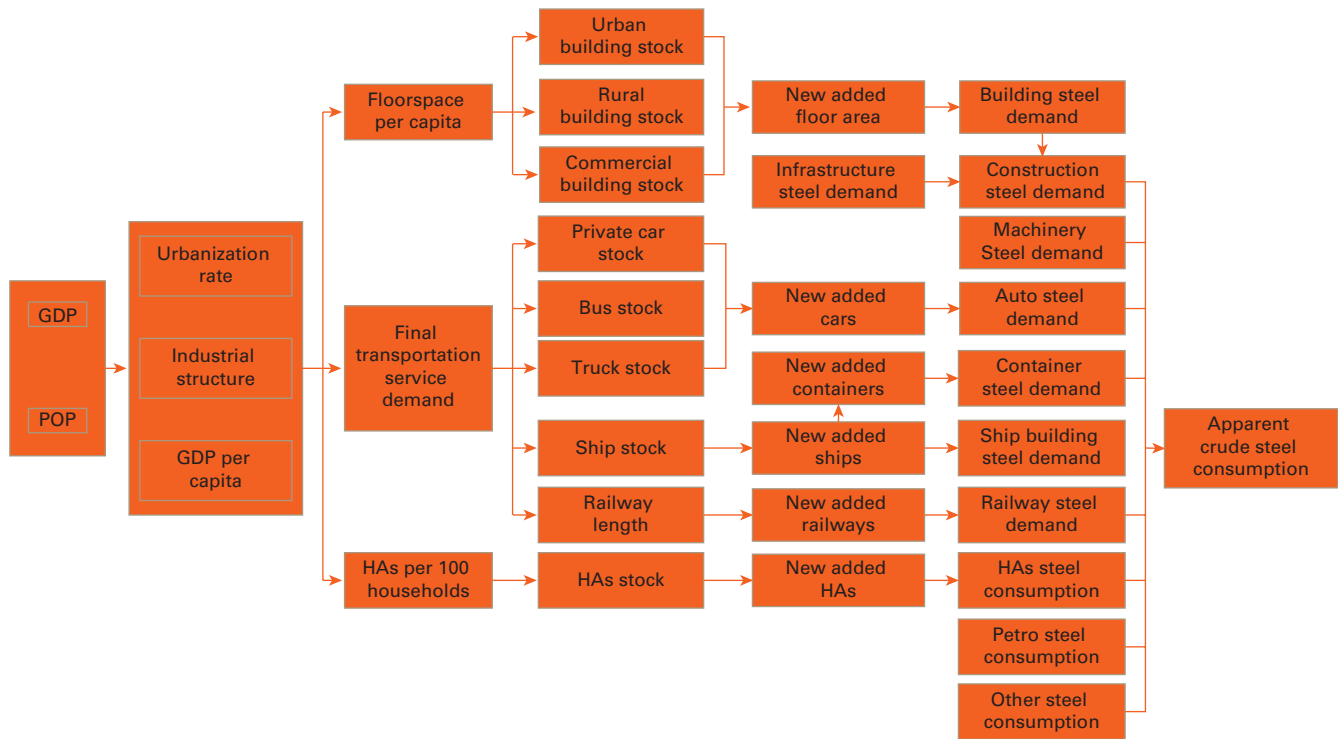

7.5 percent, 6 percent, 4.5 percent, and 3.5 percent during the period 2010–20, 2020–30, 2030–40, and 2040–50, respectively. As shown in figure B.5, the future production of industry will increase slowly when compared with the increase of transportation turnover and residential energy service demand.

With the consideration of the selective two-child policy, China’s population will reach a peak in 2030—about 1.47 billion—and urbanization rate will be about 62.5 percent, then the population will steadily decrease to 1.38 billion by 2050, and the urbanization rate is expected to increase to 75.0 percent by 2050.

In addition, the basic policies laid out in the 12th and 13th Five-Year Plans including industrial structure adjustment, development of new and renewable energy, and energy efficiency improvement are properly reflected in TIMES-ChinaW as core assumptions embodied in the Base scenario, with the country’s CO₂ mitigation target added to the reference scenario, and then carried along as part of each policy scenario examined. The main data sources for TIMES-ChinaW are summarized in table B.1.

Figure B.4

Production Process for Iron and Steel Sector in TIMES-ChinaW

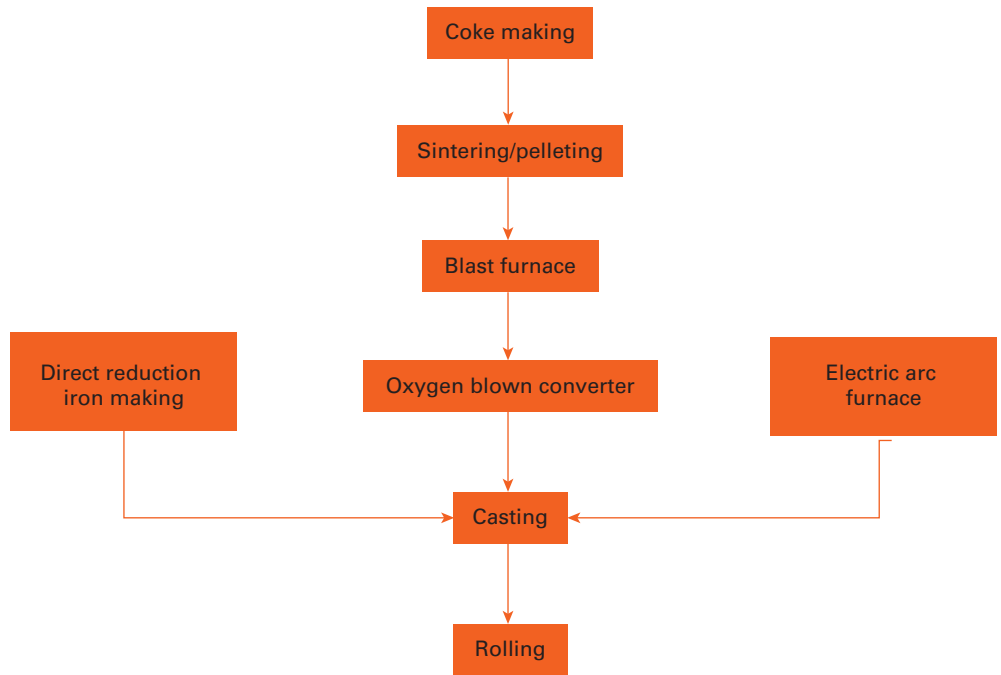

Figure B.5

Energy Service Demand (indexed from 1 in 2010)

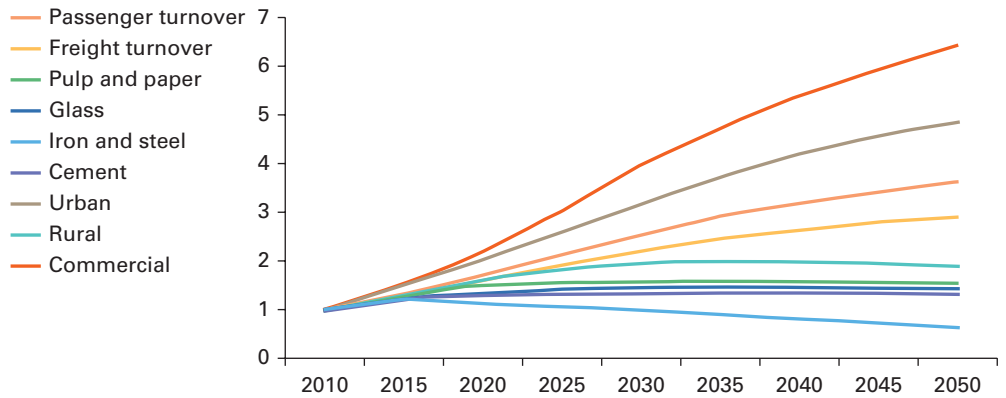

Table B.1**Major Sources for TIMES-ChinaW Energy Data**

Type	Variable	Sources	
Demand driver	Gross domestic product	Appendix B.2	
	Population	Appendix B.2	
	Urbanization rate	Appendix B.2	
	Industrial structure	Appendix B.2	
Base year picture	Energy balance	Energy Statistical Yearbook	
	Residual	Appendix C.2	
Resource supply	Coal, oil, and gas	Appendix C.1 and C.3	
	Non-fossil energy	Appendix C.4, C.5, and C.6	
Technology	Cost (activity, investment, and so on)	China-TIMES, literature review, and experts	
	Extraction, convention, power generation, demand technology	Efficiency	China-TIMES (Chen 2005, 2010, 2014, 2016)
		Lifetime	
		Activity factor	
		Emission factor	
	Water coefficient	Appendix C.8 and C.9	
Other coefficient	China-TIMES, literature review, and experts		
Energy service demand	Agriculture	Aggregated service demand	Relation with GDP and industrial structure
	Building	Floor space, saturation level, HDD/CDD of climate zone	Shi 2015
	Industry	Parameter in stock based model, saturation level	Yin 2013; Ma 2015, 2016; Li 2016
	Transportation	Speed, ratio of type, fuel efficiency, occupancy	Zhang 2015, 2016

Note: CDD = cooling degree days; GDP = gross domestic product; HDD = heating degree days.

Appendix C

Energy in China

Coal, Oil, and Gas Supply: Base Year

Data on the regional coal, oil and gas extraction in 2010 is sourced from the China Energy Statistical Yearbook and presented in table C.1.

The 2015 China Energy Statistical Yearbook updated the 2010 China energy balance, as shown in figure C.1. More than 9000 PJ of coal consumption has been added to the

Table C.1 Coal, Oil, and Gas Extraction, 2010
Petajoules

Region	Coal	Oil	Gas
Eastern Inner Mongolia	5,416	1,150	0
Ordos	21,042	353	16,657
Other region	30,093	6,183	2,185
Shanxi	15,639	0	845
Xinjiang	2,078	1,071	974

Figure C.1 Difference of Final Energy Consumption between Old and New Balance Sheet, 2010
Petajoules

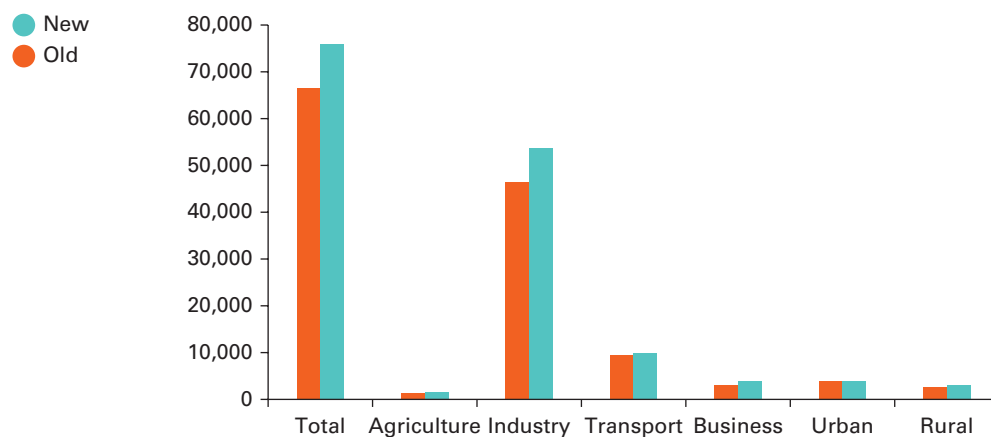

old statistics, with 81 percent of that added to the industrial coal consumption. In terms of the modeling, as the provincial balance sheets in the Energy Bases remained unchanged, the added coal was placed into the Other region to keep the data of Energy Bases consistent with their provincial balance sheets. Furthermore, as the output in different industry subsectors (such as steel and cement) remained unchanged, the added coal use was attributed to other heat usage for industry.

Installed Power Plants Capacity and Cooling Requirements

Data on the regional power capacity by technology in 2010 as presented in the “Power Plants” section in chapter 4 and compiled in table 4.2 is extracted from China’s compiled power industry statistics.

Air-cooling capacity in 2010 was 81 GW. All of the ultra-super critical, super-critical, and subcritical power plants in Eastern Inner Mongolia, Ordos, Shanxi, and Xinjiang, and part of the ultra-supercritical in the Other region are assumed to use air-cooling.

The regional coal-fired power plant capacity of recirculating cooling and air-cooling were assumed as in tables C.3 and C.4.

Table C.2 Power Capacity of Air Cooling, 2010
Gigawatts

Region	Ultra-supercritical	Super critical	Subcritical
Eastern Inner Mongolia	2.00	3.13	2.29
Ordos	9.95	15.02	12.39
Other region	18.06	0.00	0.00
Shanxi	4.23	6.85	5.29
Xinjiang	0.21	0.67	0.91

Table C.3**Power Capacity with Water Cooling (Recirculating), 2010**
Gigawatts

Region	Ultra-supercritical	Super critical	Subcritical	Super high pressure	High pressure
Eastern Inner Mongolia	0.00	0.00	0.00	3.49	0.38
Ordos	0.00	0.00	0.00	11.75	4.54
Other region	49.63	65.08	48.26	57.24	57.85
Shanxi	0.00	0.00	0.00	7.55	5.20
Xinjiang	0.00	0.00	0.00	3.92	0.80

Table C.4**Power Capacity of Water Cooling (Once-Through), 2010**
Gigawatts

Region	Ultra-supercritical	Super critical	Subcritical	Super high pressure	High pressure
Eastern Inner Mongolia	0.00	0.00	0.00	0.00	0.00
Ordos	0.00	0.00	0.00	0.00	0.00
Other region	13.92	18.25	13.53	16.05	16.22
Shanxi	0.00	0.00	0.00	0.00	0.00
Xinjiang	0.00	0.00	0.00	0.00	0.00

Coal, Oil, and Gas Potential

Data on the proven remaining coal, oil, and conventional national gas reserves as shown in table C.5, and shale gas and coal bed methane potentials, as presented in table C.6 is obtained from China Statistical Yearbooks.

Hydro Potential

According to the results on the National Hydropower Resources Survey, the theoretical potential of hydropower resources in China is 694 gigawatts (GW), annual power

Table C.5 Proved Remaining Reserves
Petajoules

Region	Oil	Natural gas	Coal
Eastern Inner Mongolia	1,627	14,169	819,068
Ordos	18,834	36,382	1,276,760
Other region	91,000	63,148	1,673,140
Shanxi	0	0	1,765,669
Xinjiang	21,417	33,577	310,265

Table C.6 Alternative Gas Potential
Petajoules

Region	Shale gas	Coalbed methane
Eastern Inner Mongolia	74,431	n.a.
Ordos	161,332	3,187
Other region	568,168	n.a.
Shanxi	25,330	7,146
Xinjiang	148,472	n.a.

Note: n.a. = not available.

Table C.7 Hydro Potentials
Gigawatts

Region	Theoretical reserves	Technical available	Economical available
Eastern Inner Mongolia	1.16	0.52	0.51
Ordos	34.41	20.81	19.02
Other region	5.63	4.02	3.97
Shanxi	38.18	16.56	15.67
Xinjiang	615.01	499.72	362.62

output 6,080 billion kilowatt-hours (kWh), technical exploitable capacity 542 GW, technical exploitable annual power output 2470 billion kWh. At present, the exploited installed capacity is 130 GW and the annual power output is 525.9 billion kWh. These unused hydropower resources are mostly located in the western part of China.

Wind Potential

Considering natural geographical condition and government policies on the development of wind power, ignoring those areas with less than 1.5 megawatts per square kilometer install capacity, the total amount of technical available wind power is 2,000 GW (50 meters), 2,600 GW (70 meters) and 3,400 GW (100 meters). provides a snapshot of the wind potential in China. Eastern Inner Mongolia (1,500 GW) has the highest amount of wind power potential, followed by Xinjiang (400 GW) and Gansu (240 GW), where table C.8 shows the potential by Energy Base.

Solar Potential

The solar energy potential is shown in figure 4.2. The northeast, northwest, and southwest part of China have a large amount of solar potentials, with average annual available hours of more than 1,100. Among these regions, Xinjiang, Tibet, Gansu, and Inner Mongolia have more than 1,500 available hours. Chongqing, Guizhou, Hunan,

Table C.8 Wind Power Potential, by Region
Gigawatts

Region	Potential
Eastern Inner Mongolia	600
Ordos	1140
Other region	360
Shanxi	100
Xinjiang	400

and Hubei are the regions with limit solar potential, with less than 800 annual available hours.

Costs

The cost data are the same as in the original TIMES-China model, other than coal and gas transportation from Eastern Inner Mongolia, Ordos, Shanxi and Xinjiang to the Other region, which uses the update costs shown in table C.9.

Coal Chemical Industry

As reflected in tables C.10 and C.11, in 2010 the only coal-to-liquid-directly project is the 1,080 kilotons per annum in Ordos, which is the only one in process in 2015. In 2010, both Ordos and Shanxi have a project of 160 kilotons per annum. In 2015, as the 1,000 kilotons per annum project in Yulin, Shaanxi becomes operational, the capacity of Ordos increase to 1,160 kilotons per annum. Nowadays, there are 55 coal to gas project (in operation, in prework, signed, planned), which is distributed more in west than east and more in north than south. The capacity grew rapidly from 0.4 billion m³ per annum in 2010 to 3.1 billion m³ per annum in 2015.

Table C.9 Coal and Gas Transportation Cost (with Distance under Consideration)

Transportation type	Coal transportation	Gas transportation
	yuan/t	yuan/m ³
Eastern Inner Mongolia to Other region	130	0.315
Ordos to Other region	90	0.265
Shanxi to Other region	64	0.217
Xinjiang to Other region	200	0.505

Table C.10**Coal to Liquid Project, 2015**

Facility name	Location	Capacity (kilotons per annum)	Operation time
Shenhua direct coal to liquid project	Ordos	1080	In the second half year of 2010
Shenhua indirect coal to liquid project	Ordos	180	Stopped
Yitai indirect coal to liquid project	Ordos	160	2009
Luan indirect coal to liquid project	Shanxi	160	2009
Yankuang indirect coal to liquid project	Ordos	1000	2009

Table C.11**Coal to Gas Project, 2015**

Facility name	Location	Capacity (BCM/a)	Operation time
Datangkeqi coal to gas project 40 BCM/a (first phase)	Eastern Inner Mongolia	1.33	In the second half year of 2010
Qinghuayili coal to gas project 55 BCM/a (first phase)	Xinjiang	1.375	Stopped
Huineng Ordos coal to gas project 16 BCM/a (first phase)	Ordos	0.4	2009

Note: BCM/a = billion cubic meter per annum.

Water Factors for Power Generation

The water factors used for coal-fired power plant are mainly taken from previous research (Fthenakis and Kim 2010; Qin and others 2015; Fricko and colleagues 2016). Water factors for the high-pressure and super high-pressure coal-fired power plant are assumed to be the same as subcritical coal-power plant. Factors of three cooling types (water recirculating cooling, air cooling, once-through cooling) are shown in table C.12.

Table C.12**Water Withdrawal Factors for Selected Electricity Generation Technologies***Cubic meters per megawatt-hour*

Power generation type	Water withdrawal			Water consumption		
	Air	Recirculating	Once through	Air	Recirculating	Once through
Subcritical	0.29	2.6	100	0.29	1.96	0.29
Subcritical with CCS	-	5.9	-	-	5.9	-
Supercritical	0.4	2.3	90	0.4	1.95	0.26
Supercritical with CCS	-	4.83	-	-	4.83	-
Ultra-supercritical	0.31	2.3	80	0.23	2.11	0.23
Ultra-supercritical with CCS	-	4.25	-	-	4.25	-
IGCC	-	1.76	-	-	1.42	-
IGCC with CCS	-	2.5	-	-	2.3	-
NGCC	0.015	1.03	43.1	0.015	0.2	43.1
NGCC with CCS	-	1.88	-	-	1.88	-
Biomass	0.13	3.32	132.5	0.13	3.32	132.5
Biomass with CCS	-	4.54	-	-	4.54	-
Solar PV		0.015			0.015	
Solar CSP	0.15	3.7	-	0.15	3.7	-
Wind		0.004			0.004	
Geothermal	0.51	6.81	-	0.51	6.81	-
Nuclear	-	2.99	162.5	-	2.79	1.5

Note: CCS = carbon capture and storage; CSP = concentrating solar power; PV = photovoltaic; NGCC = natural gas combined cycle.

Water Factors for Other Energy-Related Activities

The water factors for coal, oil and gas mining are from each province's Industry withdraw water quota and the report were provided by Ministry of Water Resources and are summarized in table C.13. Note that each province has established local water use standards (Ministry of Industry and Information Technology, 2013; General Office of Shaanxi Provincial People's Government, 2014; General Office of Shanxi Provincial People's government, 2015; Gansu Water Resource Department, 2011; Xinjiang Water Resources Department, 2006; Inner Mongolia Water Resource Department, 2009; Water Resource Department, 2007; Ministry of Water Resources, 2010 and 2012).

Table C.13

Water Withdrawal Factors in Energy Extraction and Other Conversion Process

Process	Water withdrawal
Coal mining (m ³ /t)	3.4
Oil extraction (m ³ /bbl)	1
Gas extraction (m ³ /TJ)	1.6
Coal washing (m ³ /t)	2.5
Coal to gas (m ³ water/m ³ gas)	0.008
Coal to liquids (m ³ /t)	10
Oil refinery (m ³ /TJ)	273

Note: bbl = billion barrels; t = ton; m³ = cubic meters; TJ = terajoule.

References

- Chen, Wenying. 2005. "The Costs of Mitigating Carbon Emissions in China: Findings from China MARKAL-MACRO Modeling." *Energy Policy* 33 (7): 885–96.
- Chen, Wenying, Hualin Li, and Zongxin Wu. 2010. "Western China Energy Development and West to East Energy Transfer: Application of the Western China Sustainable Energy Development Model." *Energy Policy* 38 (11): 7106–20.
- Chen, Wenying, Zongxin Wu, Jiankun He, Pengfei Gao, and Shaofeng Xu. 2007. "Carbon Emission Control Strategies for China: A Comparative Study with Partial and General Equilibrium Versions of the China MARKAL Model." *Energy* 32 (1): 59–72.
- Chen, Wenying, Xiang Yin, and Ding Ma. 2014. "A Bottom-Up Analysis of China's Iron and Steel Industrial Energy Consumption and CO₂ Emissions." *Applied Energy* 136: 1174–83.
- Chen, Wenying, Xiang Yin, and Hongjun Zhang. 2013. "Towards Low Carbon Development in China: A Comparison of National and Global Models. Climatic Change." *Climatic Change* 136 (1): 95–108.
- China Electricity Council. 2011a. "Annual Development Report of China's Power Industry." China Electricity Council, Beijing, China.
- China Electricity Council. 2011b. "China Electricity Yearbook 2011." China Electricity Council, Beijing, China.
- China Electricity Council 2016. "Annual Development Report of China's Power Industry." China Electricity Council, Beijing, China.
- CMA (China's Meteorology Administration). 2011. Investigation and evaluation of wind energy resources in China. CMA (China's Meteorology Administration) wind and solar energy resources center, Beijing, China.
- CMA (China's Meteorology Administration). 2014. Wind and solar energy resources center, China's Wind and Solar Energy Resources Bulletin, 2014
- CNPC Economic and Technology Research Institute. 2016. "World and China Energy Outlook 2050." CNPC Economic and Technology Research Institute. Beijing, China.
- Dubreuil, Aurelie, Edi Assoumou, Stéphanie Bouckaert, Sandrine Selosse, and Nadia Maïzi. 2013. "Water Modeling in an Energy Optimization Framework: The Water-Scarce Middle East Context." *Applied Energy* 101: 268–79.
- Feng, Yongheng, Zhang Shihuang, He Fanneng, and Zhou Zhaoyuan. 2014. "Separate Reconstruction of Chinese Cropland Grid Data in the 20th Century." *Progress in Geography* 33 (11): 1546–55.
- Fischer, G., F. Nachtergaele, S. Prieler, and HTV Velthuizen, Lverelst. 2008. "Global Agro-Ecological Zones Assessment for Agriculture (GAEZ 2008)." International Institute of Applied Systems Analysis (IIASA), Laxenburg, Austria, and Food and Agriculture Organization (FAO), Rome, Italy.
- Fthenakis, Vasilis, and Hyung Chul Kim. 2010. "Life-Cycle Uses of Water in U.S. Electricity Generation." *Renewable and Sustainable Energy Reviews* 14 (7): 2039–48.
- Fricko, Oliver, Simon C. Parkinson, Nils Johnson, Manfred Strubegger, Michelle T. H. van Vliet, and Keywan Riahi. 2016. "Energy Sector Water Use Implications of a 2°C Climate Policy." *Environmental Research Letters* 11 (3): 1–10.
- . 2011. "The Comprehensive Program for 12th Five-Year Plan of Energy Saving and Emission Reduction." http://www.gov.cn/zwggk/2011-09/07/content_1941731.htm.
- Gansu Water Resource Department. 2011. Water quota of industry in Gansu Province, Gansu Provincial Water Resource Department, Gansu, China.
- General Office of Shaanxi Provincial People's Government, 2014. Industry water-use quota of Shaanxi Province (DB 61/T 943-2014), Shaanxi: Shaanxi Provincial Bureau of Quality and Technical Supervision.
- General Office of Shanxi Provincial People's government, 2015. Water quota of Shanxi province (DB14/T 1049.2-2015), Shanxi: Shanxi Provincial Bureau of quality and technical supervision.
- Gu, Zongqin. 2016. "Development of China's Modern Coal Chemical Industry." Coal Processing and Comprehensive Utilization. Beijing, China.
- Guan, Zhiqiang, and Hal Gurgenci. 2009. "Dry Cooling Technology in Chinese Thermal Power Plants Cooling Technology in Thermal Power Wet/Dry Cooling Towers." Paper presented at the Australian Geothermal Energy Conference 2009. https://www.geothermal-energy.org/pdf/IGAstandard/AGEC/2009/Guan_Gurgenci_2009.pdf.

- Inner Mongolia Water Resource Department, 2009, Water quota of industry in Inner Mongolia, Water Resource Department.
- Inner Mongolia Water Resources Department, 2012. Rational Utilization and Protection of Water Resources in the Inner Mongolia Autonomous Region in 12th Five-Year Plan, 2012.
- The International Energy Agency Energy Technology Systems Analysis Program (IEA-ETSAP). 2005. "Documentation of MARKAL/TIMES Models." IEA, Paris. <http://www.iea-etsap.org>.
- Jiang, Beilei, Geng Leihua, Liu Heng, Zhao Zhixuan, Jia Renfu. 2014. "Driving Factor Analysis and the Spatial Regionalization on the Industrial Water Use Efficiency in China." *Resource Science* 36 (11): 2231–39.
- Lei, Yui-Tao, and Li-Ping Huang. 2015. "Regional Differences in Industrial Water Consumption Efficiency and Its Influencing Factors for China's Major Industrial Provinces: A Study of Provincial Panel Data Based on SFA." *China Soft Science* 4: 155–64.
- Li, Hong. 2008. "Coal Transportation in China: Capacity, Loss and Cost." China Market Press. Beijing, China.
- Li, Jugen, and Shi Lishan. 2006. "Brief Description of Hydropower Resources in China." *Water Power* 32 (1): 3-7.
- Li Xiaoyun, Xi Bing, and Zhang Hua. 2008. "Water Withdrawal for Thermal Power Plant and Water Saving Technologies." China Water and Power Press. Beijing, China.
- Li, Xin, Kuishuang Feng, Yim Ling Siu, and Klaus Hubacek. 2012. "Energy-Water Nexus of Wind Power in China: The Balancing Act Between CO₂ Emissions and Water Consumption." *Energy Policy* 45 (11): 440–48.
- Ma, Ding, Chen Wenying, Yin Xiang, and Wang Lining. 2016. "Quantifying the Co-Benefits of Decarbonisation in China's Steel Sector: An Integrated Assessment Approach." *Applied Energy* 162 (C): 1225–37.
- Ma, Ding, Ali Hasanbeigi, Lynn Price, and Chen Wenying. 2015. "Assessment of Energy-Saving and Emission-Reduction Potentials in China's Ammonia Industry." *Clean Technologies and Environmental Policy* 17: 1633–44.
- Ma, Ding, Ali Hasanbeigi, and Chen Wenying. 2014. "Energy-Efficiency and Air Emissions Reduction Opportunities for the Ammonia Industry in China." Lawrence Berkeley National Laboratory Report, LBNL-183064. San Francisco. U.S.A.
- Mausser, Wolfram, and Heike Bach. 2009. "PROMET – Large-Scale Distributed Hydrological Modelling to Study the Impact of Climate Change on the Water Flows of Mountain Watersheds." *Journal of Hydrology* 376 (3–4): 362–77.
- Ministry of Environmental Protection. 2013. "Annual Statistic Report on Environment." Ministry of Environmental Protection. Beijing, China.
- Ministry of Industry and Information Technology, Ministry of Water Resources, National Bureau of Statistics, and National Office of Water Conservation. 2013. "Guidelines for Water Efficiency in Key Industrial Sectors." <http://www.miit.gov.cn/n1146295/n1652858/n1652930/n3757016/c3762100/content.html>.
- Ministry of Water Resources. 2010 National Comprehensive Water Resources Planning. 2010. Ministry of Water Resources. Beijing, China.
- Ministry of Water Resources. 2012. "The 12th Five-Year Plan for the Water Resource Development." Ministry of water resources. Beijing, China http://www.nea.gov.cn/2012-06/26/c_131677331.htm.
- Ministry of Water Resources of the People's Republic of China, Regulation for Economic Evaluation of Water Conservancy Construction Projects (SL 72-2013), 2013, Beijing: China WaterPower Press.
- National Bureau of Statistics. 2011. *China Energy Statistical Yearbook*. Beijing: China Statistics Press.
- National Bureau of Statistics. 2016. *China Energy Statistical Yearbook*. Beijing, China Statistics Press.
- National Development and Reform Commission. 2004. "Inform on the Planning and Construction of Coal-Fired Plant." National Development and Reform Commission. Beijing, China.
- National Development and Reform Commission. 2016. The 13th Five-Year Plan for Development of Coal Chemical Industry." National Development and Reform Commission, Beijing, China.
- National Development and Reform Commission and National Energy Administration. 2016b. "Electric Power Development Planning in 13th Five-Year Plan." National Energy Administration. Beijing, China.

- National Energy Administration. 2012. "The 12th Five-Year Plan for the Development of Renewable Energy." National Energy Administration. Beijing, China. http://www.nea.gov.cn/2012-08/08/c_131767651.htm.
- National Energy Administration. 2014. "Rules of Retirement and Transform of Sub-Critical Coal-Fired Power Plant." National Energy Administration, Beijing, China.
- . 2016. "The 13th Five-Year Plan for Energy Development." National Energy Agency. Beijing, China.
- National Energy Agency and National Development and Reform Commission. 2016. "Roadmap of Creative Reform of Energy Technologies (2016–2030)." National Energy Agency and National Development and Reform Commission. Beijing, China.
- Pan, Lingying, Pei Liu, Linwei Ma, and Li Zheng. 2012. "A Supply Chain Based Assessment of Water Issues in the Coal Industry in China." *Energy Policy* 48: 93–102.
- Plappally, A. K., and J. H. Lienhard V. 2012. "Energy Requirements for Water Production, Treatment, End Use, Reclamation, and Disposal." *Renewable and Sustainable Energy Reviews* 16 (7): 4818–48.
- Pollard, David, and Starley L. Thompson. 1995. "Use of a Land-Surface-Transfer Scheme (LSX) in a Global Climate Model: The Response to Doubling Stomatal Resistance." *Global and Planetary Change* 10 (1): 129–61.
- Qin, Ying, Elizabeth Curmi, Grant M. Kopec, Julian M. Allwood, and Keith S. Richards. 2015. "China's Energy-Water Nexus—Assessment of the Energy Sector's Compliance With the '3 Red Lines' Industrial Water Policy." *Energy Policy* 82: 131–43.
- Renewable Energy Development Project of China and Denmark. 2014. "Roadmap of Renewable Energy Technology Development." National Renewable Energy Center. Beijing, China.
- Riahi, Keywan, Shilpa Rao, Volker Krey, Cheolhung Cho, Vadim Chirkov, Guenther Fischer, Georg Kindermann, Nebojsa Nakicenovic, and Peter Rafaj. 2011. "RCP8.5: A Scenario of Comparatively High Greenhouse Gas Emissions." *Climatic Change* 109: 33–57.
- Shi, Jingcheng, Chen Wenying, and Yin Xiang. 2015. "Modelling Building's Decarbonization with Application of China TIMES Model." *Applied Energy* 162: 1303–12.
- State Council of China. 2011. "The 12th Five-Year Plan for Economic and Social Development." State Council of China. Beijing, China. http://www.gov.cn/2011lh/content_1825838.htm.
- State Council of China. 2013. "The 12th Five-Year Plan for the Development of Energy Industry." State Council of China. Beijing, China. http://www.gov.cn/zwggk/2013-01/23/content_2318554.htm.
- State Council of China. 2014. Energy Development Strategy Action Plan (2014–2020) State Council of China. Beijing, China.
- Song, Xianfang, Bu Hongmei, and Ma Ying. 2012. "Coal and Water: Development of Coal Base and Water Resources." China Environmental Science Press. Beijing, China.
- Taylor, Karl E., Ronald J. Stouffer, and Gerald A. Meehl. 2012. "An Overview of CMIP5 and the Experiment Design." *Bulletin of the American Meteorological Society* 93 (4): 485–98.
- Thompson, Starley L., and David Pollard. 1995. A Global Climate Model (GENESIS) with a Land-Surface-Transfer Scheme (LSX). Part 1: Present-Day Climate. *Journal of Climate* 8: 1104–21.
- Thomson, Allison M., Katherine V. Calvin, Steven J. Smith, G. Page Kyle, April Volke, Pralit Patel, Sabrina Delgado-Arias, Ben Bond-Lamberty, Marshall A. Wise, Leon E. Clarke, and James A. Edmonds. 2011. "RCP4.5: A Pathway for Stabilization of Radiative Forcing by 2100." *Climatic Change* 109: 77–94.
- Tsinghua-BP Clean Energy Centre. 2011. "Water Issues in the Coal Supply Chain in China." ESC Project Report. Tsinghua University, Beijing, China.
- van Vuuren, Detlef P., Elke Stehfest, Michel G. J. den Elzen, Tom Kram, Jasper van Vliet, Sebastiaan Deetman, Morna Isaac, Kees Klein Goldewijk, Andries Hof, Angelica Mendoza Beltran, Rineke Oostenrijk, and Bas van Ruijven. 2011. "RCP26: Exploring the Possibility to Keep Global Mean Temperature Increase Below 2°C." *Climatic Change* 109: 95–116.
- Voltaire, A., E. Sanchez-Gomez, D. Salas y Méliá, B. Decharme, C. Cassou, S. Senesi, S. Valcke, I. Beau, A. Alias, M. Chevallier, M. Deque, H. Douville, E. Fernandez, G. Madec, E. Maïsonnave, M.-P. Moine, S. Planton, D. Saint-Martin, S. Szopa, S. Tyteca, R. Alkama, S. Belamari, A. Braun, L. Coquart, F. Chauvin. 2013. "The CNRM-CM5. 1 Global Climate Model: Description and Basic Evaluation." *Climate Dynamics* 40: 2091–21.

- Water Resource Department, 2007, Provincial Water quota for each province in China, Department of Water Resource Department. Beijing, China: <http://www.doc88.com/p-0704698388800.html>.
- Williams, Ellen, John Simmons, and BP. 2013. "Water in the Energy Industry: An Introduction." <https://www.bp.com/content/dam/bp/pdf/sustainability/group-reports/BP-ESC-water-handbook.pdf>.
- World Bank. 2016. "Thirsty Energy Case Study: South Africa." Report, World Bank, Washington, DC.
- Maria. Wurtzinger, and Philipp. Nagel. 2010. "The Case for Dry Cooling Technologies." http://www.spx.com/en/multimedia-library/pdf/spx-pdf/white-papers/SPX_Dry_Cooling_WP.pdf.
- Xie, Pingping, Mingyue Chen, Song Yang, Akiyo Yatagai, Tadahiyo Hayasaka, Yoshihiro Fukushima, and Changming Liu. 2007. "A Gauge-Based Analysis of Daily Precipitation over East Asia." *Journal of Hydrometeorology* 8 (3): 607–26.
- Xinjiang Water Resources Department, 2006. Water quota of industry in Xinjiang, Xinjiang Water Resources Department, Xinjiang, China.
- Xu, Ying, Xuejie Gao, Yan Shen, Chonghai Xu, Ying Shi, and F. Giorgi. 2009. "A Daily Temperature Dataset over China and Its Application in Validating a RCM Simulation." *Advances in Atmospheric Sciences* 26 (4): 763–72.
- Yang, C., Z. Yu, Z. Lin, and Z. Hao. 2007. "Method Study of Construction Digital Watershed for Large-Scale Distributed Hydrological Model." *Progress in Geography* 26 (1): 68–76.
- Yang, Chuanguo, Zhaohui Lin, Zhongbo Yu, Zhenchun Hao, and Shaofeng Liu. 2011. "Analysis and Simulation of Human Activity Impact on Streamflow in the Huaihe River Basin with a Large-Scale Hydrologic Model." *Journal of Hydrometeorology* 11 (3): 810–21.
- Yu, F. X., Chen, J. N., and S. Y. Zeng. 2011. "Sustainability of Thermal Electricity Generation in China: A Perspective on Water Resource." Paper presented at the 2011 International Conference on Environmental Systems Science and Engineering.
- Yu, Z., M. N. Lakhtakia, B. Yarnal, R. A. White, D. A. Miller, B. Frakes, E. J. Barron, C. Duffy, F. W. Schwartz. 1999. "Simulating the River-Basin Response to Atmospheric Forcing by Linking a Mesoscale Meteorological Model and Hydrologic Model System." *Journal of Hydrology* 218 (1): 72–91.
- Yu, Zhongbo, David Pollard, and Li Cheng. 2006. "On Continental-Scale Hydrologic Simulations with a Coupled Hydrologic Model." *Journal of Hydrology* 331 (1): 110–24.
- Zhang, Hongjun, and Wenying Chen. 2015. "The Role of Biofuels in China's Transport Sector in Carbon Mitigation Scenarios." *Energy Procedia* 75: 2700–05.
- Zhang, Hongjun, Wenying Chen, and Huang Weilong. 2016. "TIMES Modelling of Transport Sector in China and USA: Comparisons from a Decarbonization Perspective." *Applied Energy* 162: 1505–14.
- Zhang, Hongjun, Yin Xiang, and Wenying Chen. 2014. "A Bottom-Up Model Analysis of Transport Sector: A Study of China and USA." *Energy Procedia* 61: 895–8.
- Zhang, Jianyun, Wang Guoqing, Yang Yang, He Ruimin, Liu Jiufu. 2016. "The Possible Impacts of Climate Change on Water Security in China." *Advances in Climate Change Research* 4: 290–5.
- Zhang, Liang. 2013. "The Projection of Water Resource Demand in the Next 10 Years." <http://www.drc.gov.cn/xscg/20130625/182-224-2875257.htm>.
- Zhu, Yongnan. 2015. "Improvement of Coupled Land Surface—Hydrological Model and Its Application in Simulation and Prediction of Water Cycle." Doctoral dissertation, Hohai University, Jiangsu Sheng, China.
- Zhu, Yongnan., Lin Zhaohui, and Hao Zhenchun. 2015. "Development of Large Scale Coupled Land Surface and Hydrologic Model System and its Application in Pearl River Basin." *Journal of China Hydrology* 35 (1): 14–9.

